

Integrating the Healthcare Enterprise



5

**IHE Radiology (RAD)
Technical Framework**

10

**Volume 1
IHE RAD TF-1
Integration Profiles**

15

20

**Revision 18.0 – Final Text
August 9, 2019**

25

Please verify you have the most recent version of this document, which is published [here](#).

CONTENTS

30	1	Introduction	11
	1.1	Overview of Technical Framework	11
	1.2	Overview of Volume 1	12
	1.3	Audience	12
	1.4	Relationship to Standards	12
35	1.5	Relationship to Real-world Architectures	13
	1.6	Conventions	14
	1.6.1	Actor and Transaction Diagrams and Tables	14
	1.6.2	Process Flow Diagrams	14
	1.6.3	Normative versus informative contents of the Technical Framework	15
40	1.6.4	Technical Framework Referencing	15
	1.7	Scope Additions for 2018 – 2019	15
	1.8	Comments	15
	1.9	Copyright Permission	16
	1.10	IHE Radiology Technical Framework Development and Maintenance Process	16
45	2	Integration Profiles	20
	2.1	Integration Profiles Overview	25
	2.1.1	Scheduled Workflow (SWF)	26
	2.1.2	Patient Information Reconciliation (PIR)	26
	2.1.3	Consistent Presentation of Images (CPI)	26
50	2.1.4	Presentation of Grouped Procedures (PGP)	26
	2.1.5	Access to Radiology Information (ARI)	27
	2.1.6	Key Image Note (KIN)	27
	2.1.7	Simple Image and Numeric Report (SINR)	27
	2.1.8	Basic Security (SEC) - DEPRECATED	27
55	2.1.9	Charge Posting (CHG)	27
	2.1.10	Post-Processing Workflow (PWF)	28
	2.1.11	Reporting Workflow (RWF)	28
	2.1.12	Evidence Documents (ED)	28
	2.1.13	Portable Data for Imaging (PDI)	28
60	2.1.14	NM Image (NMI)	28
	2.1.15	Teaching File and Clinical Trial Export (TCE)	29
	2.1.16	Cross-Enterprise Document Sharing for Imaging (XDS-I.b)	29
	2.1.17	Mammography Image (MAMMO)	29
	2.1.18	Image Fusion (FUS)	29
65	2.1.19	Import Reconciliation Workflow (IRWF)	29
	2.1.20	Radiation Exposure Monitoring (REM)	30
	2.1.21	Mammography Acquisition Workflow (MAWF)	30
	2.1.22	MR Diffusion Imaging (DIFF)	30
	2.1.23	CT/MR Perfusion Imaging with Contrast (PERF)	30
70	2.1.24	Basic Image Review (BIR)	30

	2.1.25	Chest X-Ray CAD Display (CXCAD).....	30
	2.1.26	Imaging Object Change Management (IOCM).....	30
	2.1.27	Cross-Community Access for Imaging (XCA-I)	31
	2.1.28	Post Acquisition Workflow (PAWF)	31
75	2.1.29	Cross-Enterprise Document Reliable Interchange of Images (XDR-I).....	31
	2.1.30	Stereotactic Mammography Image (SMI).....	31
	2.1.31	Management of Radiology Report Templates (MRRT).....	31
	2.1.32	Scheduled Workflow.b (SWF.b)	31
	2.1.33	Invoke Image Display (IID)	31
80	2.1.34	Intentionally Left Blank	31
	2.1.35	Digital Breast Tomosynthesis (DBT).....	31
	2.1.36	Web-based Image Capture (WIC).....	32
	2.1.37	Clinical Decision Support – Order Accountable Tracking (CDS-OAT).....	32
	2.1.38	Radiation Exposure Monitoring – Nuclear Medicine (REM-NM)	32
85	2.1.39	Cross-Enterprise Remote Read Workflow Definition (XRR-WD).....	32
	2.1.40	Web-based Image Access (WIA)	32
	2.1.41	Standardized Operational Log Events (SOLE)	32
	2.1.42	Management of Acquisition Protocols (MAP).....	32
	2.1.43	Results Distribution (RD).....	32
90	2.1.44	Intentionally Left Blank	32
	2.1.45	Encounter-based Imaging Workflow (EBIW).....	32
	2.1.46	Import and Display of External Priors (IDEP).....	32
	2.2	Options to other Domains’ Profiles	33
	2.2.1	ITI-Audit Trail and Node Authentication.....	33
95	2.3	Actor Descriptions	33
	2.4	Transaction Descriptions	36
	2.5	Product Implementations	41
3		Scheduled Workflow (SWF).....	45
	3.1	Actors/Transactions	46
100	3.2	Scheduled Workflow Integration Profile Options	48
	3.2.1	HL7 v2.5.1 Option.....	50
	3.3	Scheduled Workflow Process Flow	50
	3.3.1	Administrative and Procedure Performance Process Flow	50
	3.3.2	Patient Update Flow	53
105	3.3.3	Order Change Flow.....	56
	3.3.4	Exception Management Workflow.....	60
	3.3.5	Implicit Post-Processing	65
	3.3.6	Departmental Appointment Booking.....	70
	3.4	Data Model for Scheduled Workflow.....	71
110	3.4.1	Model of the Real World	71
	3.4.2	Scheduled Workflow Concepts in Practice	74
	3.4.3	Scheduled Workflow Information Model.....	78
4		Patient Information Reconciliation (PIR)	81
	4.1	Actors/Transactions	82

115	4.2 Patient Information Reconciliation Integration Profile Options.....	84
	4.2.1 HL7 v2.5.1 Option.....	85
	4.3 Unidentified Patient Image Acquisition and Reconciliation	85
	4.3.1 Patient Information Reconciliation during Image Acquisition.....	86
	4.4 Use Cases	87
120	4.4.1 Case 1: Unidentified Patient Registered at ADT and Ordered at the Order Placer ...	87
	4.4.2 Case 2: Unidentified Patient Registered at ADT and Ordered at Department System Scheduler/Order Filler	89
	4.4.3 Case 3: Unidentified Patient Registered at ADT but Completed at Modality Prior to Order	90
125	4.4.4 Case 4: Unidentified Patient Assigned Temporary Departmental ID and Scheduled at DSS/Order Filler.....	92
	4.4.5 Case 5: Image Acquisition Completed Without Scheduling at Department System Scheduler/Order Filler	93
	4.4.6 Case 6: Patient Information Reconciliation During Image Acquisition.....	96
130	5 Consistent Presentation of Images (CPI)	98
	5.1 Actors/Transactions	98
	5.2 Consistent Presentation of Images Integration Profile Options.....	100
	5.3 Consistent Presentation of Images Process Flow.....	101
	6 Presentation of Grouped Procedures (PGP).....	104
135	6.1 Actors/Transactions	104
	6.2 Presentation of Grouped Procedures Integration Profile Options.....	105
	6.3 Presentation of Group Procedures Process Flow	106
	7 Access to Radiology Information (ARI).....	109
	7.1 Actors/Transactions	109
140	7.2 Access to Radiology Information Integration Profile Options	110
	7.3 Multiple Sources Option.....	111
	7.3.1 Requirements for the Multiple Sources Option	111
	8 Key Image Note (KIN).....	113
	8.1 Actors/Transactions	113
145	8.2 Key Image Notes Integration Profile Options	114
	8.3 Key Image Note Pattern.....	115
	9 Simple Image and Numeric Report (SINR).....	116
	9.1 Actors/Transactions	116
	9.2 Simple Image and Numeric Report Integration Profile Options	117
150	9.3 Diagnostic Report Process Flow.....	118
	9.4 Diagnostic Reporting Use Cases.....	120
	9.4.1 Simple Image Report	120
	9.4.2 Simple Image and Numeric Report	121
	9.4.3 Observation Context	122
155	10 Basic Security (SEC) - DEPRECATED	123
	11 Charge Posting (CHG).....	124
	11.1 Actors/Transactions	125
	11.2 Charge Posting Integration Profile Options.....	126

	11.3 Charge Posting Process Flow.....	128
160	11.3.1 Use Cases.....	129
	11.3.2 Technical Billing	129
	11.3.3 Professional Billing	129
	11.4 Data Model for Charge Posting	130
	11.4.1 Model of the Real World.....	130
165	12 Post-Processing Workflow (PWF).....	132
	12.1 Actors/Transactions	132
	12.2 Post-Processing Workflow Integration Profile Options	134
	12.3 Implementation Issues	135
	12.3.1 Actor Grouping Clarification	135
170	12.3.2 Input Availability.....	136
	12.3.3 Evidence Creators in Scheduled Workflow vs. Post-Processing Workflow	137
	12.4 Post-Processing Process Flow	137
	12.4.1 Computer Aided Detection Use Case.....	137
	12.4.2 3D Reconstruction Use Case	138
175	12.4.3 Post-Processing Process Flow Diagrams.....	138
	13 Reporting Workflow (RWF).....	142
	13.1 Actors/Transactions	142
	13.1.1 Actor Grouping Clarification	144
	13.1.2 Input Availability.....	145
180	13.2 Reporting Workflow Integration Profile Options	145
	13.2.1 HL7 v2.5.1 Option.....	146
	13.3 Reporting Tasks	146
	13.4 Diagnostic Reporting Use Cases.....	150
	13.4.1 Use case 1: Predefined Report.....	150
185	13.4.2 Use case 2: Workitem Deferred	151
	13.4.3 Use case 3: Direct Report Creation	152
	13.4.4 Use case 4: Interpretation and Dictation	153
	13.4.5 Use case 5: Transcription	155
	13.4.6 Use case 6: Partial completion	155
190	13.4.7 Use case 7: Verification.....	157
	13.4.8 Use case 8: Double reading	158
	13.4.9 Use case 9: Comparison	158
	13.4.10 Use case 10: Review.....	159
	13.4.11 Use case 11: Over Read.....	159
195	14 Evidence Documents (ED).....	161
	14.1 Actors/Transactions	161
	14.2 Evidence Documents Integration Profile Options	162
	14.3 Evidence Document Process Flow.....	163
	15 Portable Data for Imaging Integration Profile (PDI)	166
200	15.1 Actors/ Transactions	166
	15.2 Portable Data for Imaging Integration Profile Options.....	168
	15.3 Portable Data for Imaging Process Flow	168

	15.3.1	Use Cases.....	169
	15.3.2	Process Flow Description.....	170
205	15.4	Media Content.....	173
	15.4.1	DICOM Content.....	173
	15.4.2	Web Content Option.....	173
	15.4.3	Other Content.....	173
	15.4.4	Media Type (CD, DVD and USB).....	174
210	15.5	Security and Privacy Aspects.....	174
	15.6	PDI Cross Profile Considerations.....	175
	15.6.1	ITI Cross-Enterprise Document Media Interchange (XDM).....	175
	16	NM Image Integration Profile.....	176
	16.1	Actors/ Transactions.....	176
215	16.2	NM Image Integration Profile Options.....	177
	16.3	NM Image Process Flow.....	179
	17	Teaching File and Clinical Trial Export (TCE).....	180
	17.1	Actors/Transactions.....	180
	17.2	Teaching File and Clinical Trial Export Integration Profile Options.....	181
220	17.2.1	De-identify Pixel Data Option.....	182
	17.2.2	Remap Identifiers Option.....	182
	17.2.3	Additional Teaching File Information Option.....	183
	17.2.4	Delay for Reason Option.....	183
	17.3	Implementation Issues.....	183
225	17.4	Teaching File and Clinical Trial Export Integration Profile Process Flow.....	184
	17.4.1	Teaching File Use Cases.....	186
	17.4.2	Clinical Trial Use Cases.....	190
	17.4.3	Research Collection Use Cases.....	191
	17.4.4	Publication Authoring Use Cases.....	191
230	18	Cross-Enterprise Document Sharing for Imaging (XDS-I.b) Integration Profile.....	192
	18.1	Actors/ Transactions.....	193
	18.2	Integration Profile Options.....	195
	18.2.1	Set of DICOM Instances Option.....	196
	18.2.2	PDF Report Option.....	196
235	18.2.3	CDA Wrapped Text Report Option.....	196
	18.2.4	CDA Imaging Report with Structured Headings Option.....	196
	18.2.5	Remove Imaging Document Option.....	196
	18.2.6	Reference ID Option.....	197
	18.3	Image Information Sharing Process Flow.....	198
240	18.3.1	Overview of Imaging Information Sharing Use Cases.....	198
	18.3.2	Assumptions.....	199
	18.3.3	Use cases.....	200
	18.3.4	Queries.....	209
	18.4	Consumer Processing.....	209
245	18.4.1	Consumer Processing – Set of DICOM Instances.....	209
	18.5	Patient Information Reconciliation.....	209

	18.6 Security Considerations	210
	19 Mammography Image Integration Profile.....	211
	19.1 Actors/ Transactions	211
250	19.2 Mammography Image Integration Profile Options.....	213
	19.3 Mammography Image Profile Process Flow.....	214
	20 Image Fusion (FUS).....	215
	21 Import Reconciliation Workflow (IRWF)	216
	21.1 Actors/Transactions	216
255	21.2 Import Reconciliation Workflow Integration Profile Options.....	218
	21.2.1 Scheduled Import Option	219
	21.2.2 Unscheduled Import Option	219
	21.3 Integration Workflow Process Flow	219
	21.3.1 Import Process Flow	219
260	21.3.2 Import Exception Management Workflow.....	225
	22 Radiation Exposure Monitoring (REM) Integration Profile	226
	22.1 Actors/ Transactions.....	227
	22.2 Radiation Exposure Monitoring Integration Profile Options.....	229
	22.3 Radiation Exposure Monitoring Process Flow	229
265	22.3.1 General Case	230
	22.3.2 Real-World Use Cases	231
	22.3.3 Example REM Profile Deployments	234
	22.4 Radiation Exposure Monitoring Profile Security Considerations.....	235
	22.5 Relation to Other Profiles.....	236
270	22.5.1 Radiology Profiles.....	236
	22.5.2 ITI Profiles	236
	23 Mammography Acquisition Workflow (MAWF).....	237
	24 MR Diffusion Imaging (DIFF)	237
	25 CT/MR Perfusion Imaging with Contrast (PERF).....	237
275	26 Basic Image Review (BIR)	237
	27 Chest X-Ray CAD Display (CXCAD)	237
	28 Imaging Object Change Management (IOCM).....	238
	28.1 Actors/ Transactions	238
	28.2 Imaging Object Change Management Integration Profile Options	240
280	28.3 Imaging Object Change Management Integration Profile Actor Groupings and Profile Interactions.....	240
	28.4 Imaging Object Change Management Process Flow	241
	28.4.1 Use Case: Data Retention Expiration	242
	28.4.2 Use Case: Image Rejection for Quality Reasons.....	243
285	28.4.3 Use Case: Image Correction for Patient Safety Reasons.....	244
	28.4.4 Use Case: Object Correction due to Modality Worklist Selection Error	246
	28.5 Imaging Object Change Management Security Considerations	251
	29 Cross-Community Access for Imaging (XCA-I)	253
	29.1 Actors/ Transactions	253
290	29.1.1 Actor Requirements.....	255

	29.2XCA-I Profile Options	255
	29.3XCA-I Process Flow	255
	29.3.1 Use Case – Image set sharing between communities	255
	29.3.2 Detailed Interactions	256
295	29.3.3 Actor Grouping Considerations	259
	29.4XCA-I Security Considerations	260
	29.4.1 XCA Risk Assessment	260
	29.4.2 Requirements/Recommendations	260
	29.4.3 Policy Choices	261
300	30 Post Acquisition Workflow (PAWF)	261
	31 Cross-Enterprise Document Reliable Interchange of Images (XDR-I)	261
	32 Stereotactic Mammography Image (SMI)	261
	33 Management of Radiology Report Templates (MRRT)	261
	34 Scheduled Workflow.b (SWF.b)	261
305	35 Invoke Image Display (IID)	262
	36 Intentionally left blank	262
	37 Digital Breast Tomosynthesis (DBT)	263
	37.1 DBT Actors, Transactions, and Content Modules	263
	37.1.1 Actor Descriptions and Actor Profile Requirements	264
310	37.2 DBT Actor Options	265
	37.2.1 Key Images Option	266
	37.2.2 Partial View Option	266
	37.2.3 For Presentation Breast Projection X-Ray Images Option	266
	37.2.4 For Processing Breast Projection X-Ray Images Option	266
315	37.2.5 User Annotation Option	266
	37.2.6 Media Creation Option	267
	37.3 DBT Required Actor Groupings	267
	37.4 DBT Overview	268
	37.4.1 Concepts	268
320	37.4.2 Use Cases	268
	37.5 DBT Security Considerations	276
	37.6 DBT Cross Profile Considerations	276
	38 Web-based Image Capture (WIC)	277
	39 Clinical Decision Support – Order Appropriateness Tracking (CDS-OAT)	277
325	40 Radiation Exposure Monitoring – Nuclear Medicine (REM-NM)	277
	41 Cross-Enterprise Remote Read Workflow Definition (XRR-WD)	277
	42 Web-based Image Access (WIA)	277
	43 Standardized Operational Log Events (SOLE)	277
	44 Management of Acquisition Protocols (MAP)	277
330	45 Results Distribution (RD)	277
	46 Intentionally Left Blank	278
	47 Encounter-based Imaging Workflow (EBIW)	278
	48 Import and Display of External Priors (IDEP)	278
	Appendix A: Clarification of Accession Number and Requested Procedure ID	279

335	A.1 Structure of an Order for Imaging Service	279
	Appendix B: Topics for Standards Corrections or Supplements	281
	B.1 HL7 Topics	281
	B.1.1 Version 2.5.....	281
	B.1.2 HL7 Conformance	281
340	B.2 DICOM Topics	281
	Appendix C: Overview of the Information Exchange between Department System	
	Scheduler/Order Filler and Image Manager.....	282
	C.1 Exchange of Patient Information	282
	C.2 Exchange of Visit and Order Information	282
345	C.3 Exchange of Procedure Information	283
	Appendix D: IHE Integration Statements	284
	Appendix E: Nuclear Medicine	285
	E.1 Introduction.....	285
	E.2 NM Workflow Overview	285
350	E.2.1 Injection Steps	286
	E.2.2 Time Separated Acquisitions.....	286
	E.2.3 Reconstruction as a Separate Operation	286
	E.2.4 Acquisition Post-Processing	287
	E.2.5 Clinical Post Processing	287
355	E.2.6 Display and Reviewing.....	288
	E.2.7 Workflow Chaining	288
	E.3 NM Worklists.....	288
	E.3.1 NM Worklist Guidelines.....	288
	E.3.2 NM Worklist Examples	291
360	E.4 NM Data.....	294
	E.4.1 Study UIDs and Series UIDs	295
	E.4.2 NM Image IOD: Multi-Frames and Vectors	296
	E.4.3 Typical NM Data Dimensions	296
	E.5 NM Display.....	298
365	E.5.1 NM Intensity and Color Mapping.....	298
	E.5.2 NM Image Resizing.....	299
	E.5.3 NM Display Examples.....	301
	Appendix F: Security Environment Considerations.....	306
	Appendix G: Patient Information Reconciliation for XDS-I.b (INFORMATIVE).....	308
370	G.1 Context and Assumptions	308
	G.1.1 XDS Affinity Domain Assumptions.....	308
	G.1.2 Metadata in the Document Registry	309
	G.1.3 Patient Identity Management in the XDS Registry	309
	G.1.4 Expected Implementation Models for Patient Identity Management	309
375	G.2 Patient Information Reconciliation (PIR) in an Affinity Domain	310
	G.2.1 Patient Merge within XAD Patient Identity Domain	310
	G.2.2 Local Domain Patient Update - XAD Domain Patient ID does not change.....	311
	G.2.3 Local Domain Patient Update - XAD Domain Patient Merge	312

	G.2.4 Local Domain Patient Merge – XAD Domain Patient ID does not change	313
380	G.2.5 Local Domain Patient Merge – XAD Domain Patient Merge.....	314
	Appendix H: Security considerations for XDS-I.b (informative)	317
	Appendix I: Appendix I – Deployment of Dose Registries.....	323
	I.1 Dose Registry Deployment Issues	323
	I.1.1 Code Set Management.....	323
385	I.1.2 Configuration of Secure FTP (Submit Dose Information [RAD-63]).....	323
	I.1.3 Alternative Transport Mechanisms.....	324
	I.1.4 Encapsulated Dose Registry Submission.....	324
	I.2 Real-World Projects.....	325
	I.3 Dose Monitoring Regulations	326
390	GLOSSARY	328

1 Introduction

395 Integrating the Healthcare Enterprise (IHE) is an initiative promoting the use of standards to
achieve interoperability of health information technology (HIT) systems and effective use of
electronic health records (EHRs). IHE provides a forum for volunteer committees of care
providers, HIT experts and other stakeholders in several clinical and operational domains to
reach consensus on standards-based solutions to critical interoperability issues. IHE publishes the
implementation guides they produce (called *IHE profiles*), first to gather public comment and
400 then for trial implementation by HIT vendors and other system developers.

IHE provides a process for developers to test their implementations of IHE profiles, including
regular testing events called Connectathons. After a committee determines that a profile has
undergone sufficient successful testing and deployment in real-world care settings, it is
incorporated in the appropriate IHE Technical Framework, of which the present document is a
405 volume. The Technical Frameworks provide a unique resource for developers and users of HIT
systems: a set of proven, standards-based solutions to address common interoperability issues
and support the convenient and secure use of EHRs.

Purchasers can specify conformance with appropriate IHE profiles as a requirement in requests
for proposal. Vendors who have successfully implemented IHE profiles in their products can
410 publish conformance statements (called IHE Integration Statements) in the IHE Product Registry
(<http://product-registry.ihe.net>).

The current versions of this and all IHE Technical Framework documents are available at
http://www.ihe.net/Technical_Frameworks/. Comments on this document may be submitted at
http://www.ihe.net/Radiology_Public_Comments.

415 IHE domain committees are responsible for developing and publishing Technical Framework
documents. This document is published by the IHE Radiology committees. Information on the
activities of this domain, including its committee rosters and how to participate, is available at
<http://wiki.ihe.net/index.php?title=Domains>.

420 General information about IHE, including its governance structure, sponsorship, member
organizations and work process, is available at www.ihe.net.

1.1 Overview of Technical Framework

This document, the IHE Radiology Technical Framework, defines specific implementations of
established standards to achieve integration goals that promote appropriate sharing of medical
information to support optimal patient care. It is expanded annually, after a period of public
425 review, and maintained regularly through the identification and correction of errata. The latest
version of the document is always available via the Internet at
http://www.ihe.net/Technical_Frameworks.

The IHE Radiology Technical Framework identifies a subset of the functional components of the
healthcare enterprise, called IHE actors, and specifies their interactions in terms of a set of
430 coordinated, standards-based transactions. It describes this body of transactions in progressively
greater depth. The present volume provides a high-level view of IHE functionality, showing the

transactions organized into functional units called Integration Profiles that highlight their capacity to address specific clinical needs. The subsequent volumes, 2 and 3, provide detailed technical descriptions of each IHE transaction.

435 The other domains within the IHE initiative also produce Technical Frameworks within their respective areas that together form the IHE Technical Framework. All published IHE Technical Frameworks are available at http://www.ihe.net/Technical_Frameworks.

Where applicable, references are made to other technical frameworks. For the conventions on referencing other frameworks, see Section 1.6.4 within this volume.

440 **1.2 Overview of Volume 1**

The remainder of Section 1 further describes the general nature, purpose and function of the Technical Framework. Section 2 introduces the concept of IHE Integration Profiles that make up the Technical Framework.

445 Section 3 and the subsequent sections of this volume provide detailed documentation on each integration profile, including the clinical problem it is intended to address and the IHE actors and transactions it comprises.

The appendices following the main body of the document provide detailed discussion of specific issues related to the integration profiles and a glossary of terms and acronyms used.

1.3 Audience

450 The intended audience of this document is:

- Technical staff of vendors participating in the IHE initiative
- IT departments of healthcare institutions
- Experts involved in standards development
- Anyone interested in the technical aspects of integrating healthcare information systems

455 **1.4 Relationship to Standards**

The IHE Technical Framework identifies functional components of a distributed healthcare environment (referred to as IHE actors), solely from the point of view of their interactions in the healthcare enterprise. At its current level of development, it defines a coordinated set of transactions based on the HL7^{®1} and DICOM^{®2} standards. As the scope of the IHE initiative expands, transactions based on other standards will be included as required.

460

¹ HL7 is the registered trademark of Health Level Seven International.

² DICOM is the registered trademark of the National Electrical Manufacturers Association for its standards publications relating to digital communications of medical information.

In some cases, IHE recommends selection of specific options supported by these standards; however, IHE does not introduce technical choices that contradict conformance to these standards. If errors in or extensions to existing standards are identified, IHE's policy is to report them to the appropriate standards bodies for resolution within their conformance and standards evolution strategy.

IHE is therefore an implementation framework, not a standard. Referencing IHE as a standard is inappropriate. Conformance claims by product must still be made in direct reference to specific standards. In addition, vendors who have implemented IHE integration capabilities shall use an IHE Integration Statement to describe the conformance of their product to the specifications in the IHE Technical Framework. The purpose of an IHE Integration Statement is to communicate to the users of the corresponding product the IHE capabilities it has been designed to support. Vendors publishing IHE Integration Statements accept full responsibility for their content. By comparing the IHE Integration Statements from different implementations, a user familiar with the IHE concepts of actors and integration profiles should be able to determine whether and to what extent communications might be supported between products. See Appendix D for the format of such IHE Integration Statements. IHE encourages implementers to ensure that products implemented in accordance with the IHE Technical Framework also meet the full requirements of the standards underlying IHE, allowing the products to interact, although possibly at a lower level of integration, with products that have been implemented in conformance with those standards, but not in full accordance with the IHE Technical Framework.

1.5 Relationship to Real-world Architectures

The IHE actors and transactions described in the IHE Technical Framework are abstractions of the real-world healthcare information system environment. While some of the transactions are traditionally performed by specific product categories (e.g., HIS, Electronic Patient Record, RIS, PACS, Clinical Information Systems or imaging modalities), the IHE Technical Framework intentionally avoids associating functions or actors with such product categories. For each actor, the IHE Technical Framework defines only those functions associated with integrating information systems. The IHE definition of an actor should therefore not be taken as the complete definition of any product that might implement it, nor should the framework itself be taken to comprehensively describe the architecture of a healthcare information system.

The reason for defining actors and transactions is to provide a basis for defining the interactions among functional components of the healthcare information system environment. In situations where a single physical product implements multiple functions, only the interfaces between the product and external functions in the environment are considered to be significant by the IHE initiative. Therefore, the IHE initiative takes no position as to the relative merits of an integrated environment based on a single, all-encompassing information system versus one based on multiple systems that together achieve the same end. To illustrate most dramatically the possibilities of the IHE Technical Framework, however, the IHE demonstrations emphasize the integration of multiple vendors' systems based on the IHE Technical Framework.

500 **1.6 Conventions**

This document has adopted the following conventions for representing the framework concepts and specifying how the standards upon which the IHE Technical Framework is based should be applied.

1.6.1 Actor and Transaction Diagrams and Tables

505 Each integration profile is a representation of a real-world capability that is supported by a set of actors that interact through transactions. Actors are information systems or components of information systems that produce, manage, or act on categories of information required by operational activities in the enterprise. Transactions are interactions between actors that transfer the required information through standards-based messages.

510 The tables of actors and transactions indicate which transactions each actor in a given profile must support. The convention used in these diagrams is that the arrow indicating the direction for the transaction points from the initiator of the transaction to the destination.

In some cases, a profile is dependent on a pre-requisite profile in order to function properly and be useful. For example, Presentation of Grouped Procedures depends on both Scheduled
515 Workflow and Consistent Presentation of Images being implemented as pre-requisites. These dependencies can be found by locating the desired profile in Table 2-1 and seeing which profiles are listed as required pre-requisites.

An actor must implement all required transactions in the pre-requisite profiles in addition to those in the desired profile. In some cases, the pre-requisite is that the actor selects any one of a
520 given set of profiles to satisfy the pre-requisite. For example, Post-processing depends on any one of the content profiles being supported.

1.6.2 Process Flow Diagrams

The descriptions of integration profiles that follow include Process Flow Diagrams that illustrate how the profile functions as a sequence of transactions between relevant actors.

525 These diagrams are intended to provide a “big picture” so the transactions can be seen in the context of the overall workflow. Certain transactions and activities not defined in detail by IHE are shown in these diagrams in *italics* to provide additional context on where the relevant IHE transactions fit into the broader scheme of healthcare information systems.

530 These diagrams are not intended to present the only possible scenario. Often other actor groupings are possible, and complementary transactions from other profiles may be interspersed.

In some cases, the sequence of transactions may be flexible. Where this is the case there will generally be a note pointing out the possibility of variations.

The convention used in these diagrams is that the arrow on the line for the transaction points from the initiator of the transaction to the destination.

535 **1.6.3 Normative versus informative contents of the Technical Framework**

Most parts of the Technical Framework describe required or optional characteristics of integration profiles, Actors and Transactions: these are normative. For a better understanding of the text, there also exist illustrating parts in the Technical Framework that are informative and non-normative.

540 According to IETF RFC2119, certain words indicate whether a specific content of the Technical Framework is normative: either required (e.g., “must”, “required”, “shall”) or optional (e.g., “may”, “recommended”). Informative content does not contain these key words.

1.6.4 Technical Framework Referencing

545 When references are made to a section within the same Technical Framework volume, a section number is used by itself. When references are made to other volumes or to a Technical Framework in another domain, the following format is used:

<domain designator> TF-<volume number>: <section number>, where

<domain designator> is a short designator for the IHE domain (ITI = IT Infrastructure, RAD = Radiology)

550 <volume number> is the applicable volume within the given Technical Framework (e.g., 1, 2, 3), and

<section number> is the applicable section number.

555 For example: ITI TF-1: 3.1 refers to Section 3.1 in Volume 1 of the IHE IT Infrastructure Technical Framework, RAD TF-3: 4.33 refers to Section 4.33 in Volume 3 of the IHE Radiology Technical Framework.

When references are made to specific transactions (transaction numbers) the following format is used:

<domain designator>-<transaction number>

560 For example, [RAD-4] refers to transaction number 4 (Procedure Scheduled) in the Radiology Technical Framework.

1.7 Scope Additions for 2018 – 2019

This document refers to Year 21 of the IHE initiative in the Radiology Domain. This year’s update incorporates Final Text Change Proposals.

1.8 Comments

565 HIMSS and RSNA welcome comments on this document and the IHE initiative. They should be submitted at http://www.ihe.net/Radiology_Public_Comments or to:

Chris Carr
IHE Radiology Secretary
820 Jorie Boulevard
570 Oak Brook, IL 60523
Email: radiology@ihe.net

1.9 Copyright Permission

Health Level Seven, Inc. has granted permission to the IHE to reproduce tables from the HL7 standard. The HL7 tables in this document are copyrighted by Health Level Seven, Inc. All rights reserved.
575

The National Electrical Manufacturers Association (NEMA) has granted permission to the IHE to incorporate portions of the DICOM standard.

Material drawn from these documents is credited where used.

1.10 IHE Radiology Technical Framework Development and Maintenance Process 580

The Technical Framework is being continuously extended and maintained by the IHE Technical Committees. The Development and Maintenance Process of the Framework follows a number of principles to ensure stability of the specification both vendors and users may rely upon in specifying, developing and acquiring IHE compatible products.

585 The process is intended to address the need for extensions, clarifications and corrections while maintaining backward compatibility of framework definitions as to support implementations claiming conformance to any previously defined integration profile and its actors.

To maintain stability of the IHE Technical Framework, modifications occur in a regular annual cycle (Figure 1.10-1) according to one of two controlled paths:

590 1. New Development – Extending the Existing Technical Framework

Each year, new functionality to be developed is identified by the IHE Planning Committee. The Technical Committee performs the necessary analysis and design work and generates new text for the Technical Framework.

595 Generally, new functionality is published in the form of a supplement. The scope of a supplement is to make one of the following additions to the Technical Framework:

- A new Integration Profile, usually including the introduction of new actors and transactions.
- New actors in an existing Integration Profile: These may be either actors previously defined elsewhere in the Technical Framework, or new ones not yet defined.
600 Transactions identifying the new actor's responsibilities in this profile are identified or defined and may be designated as required or optional. To avoid causing compatibility problems for systems that have already implemented that profile, no new required transactions are added for existing actors in the profile.

- 605 • New options in an existing Integration Profile: These usually add optional transactions for existing actors in the profiles, or add optional features within existing transactions.
- Major conceptual changes: They do not change the behavior of existing Integration Profiles but may imply changes or additions to actors or transactions in the future.

610 The publication process consists of certain phases and is clearly indicated on each document.

First, the text is published for Public Comment (with a “PC” designation). During the Public Comment period (typically 30 days), the text and a comment submission facility are available on the IHE Website. Following this period, the Technical Committee will review the comments.

615 Updated text of supplements is then published for Trial Implementation (with a “TI” designation), based on the modifications resulting from the comments received. After trial implementations have been judged to have sufficiently exercised the new functionality (e.g., due to experience from the Connectathon), and the text is considered sufficiently stable, the new text will be published as Final Text (with a “FT” designation).
620 Final Text Supplements will be merged at the end of the annual development cycle with the current version of the Technical Framework resulting in a new version of the Technical Framework with an increased version number.

2. Maintenance of existing Technical Framework content

625 Despite the best efforts of the Technical Committee, a published current version of the Technical Framework or Trial Implementation documents may contain text that is incorrect, incomplete or unclear. Such issues are handled as Change Proposals and cover:

- Corrections: technical issues causing non-interoperability of implementations are fixed without introducing changes in functionality of a stable Integration Profile.
- 630 • Clarifications: text that can be misunderstood or is ambiguous is made easier to understand or disambiguated, without introducing any technical changes.

The publication process is the same for both Corrections and Clarifications, and addresses both changes to Trial Implementations and changes to a current version of the Technical Framework.

635 A Submitted Change Proposal results from issues raised by users, vendors or Technical Committee members, e.g., from experiences with Trial Implementation or Final Text Integration Profiles or at a Connectathon. The resulting Change Proposal document should explicitly state:

1. the parts of the Technical Framework requested to be changed,
2. a problem description,
- 640 3. a rationale why the change is considered necessary,
4. and a solution or approach to the problem.

The Technical Committee regularly considers Change Proposals which are then either accepted or rejected.

645 A **Rejected Change Proposal** is published with a rationale from the Technical Committee explaining why the change is not appropriate.

An **Accepted Change Proposal** is assigned to a member of the Technical Committee as a work item for further investigation with the goal to produce adequate clarifications or corrections. The resulting text will again be reviewed by the Technical Committee before being approved.

650 Once approved, a **Final Text Change Proposal** is published by the Technical Committee, and then is to be considered as effective. It will be merged into the next version of the Technical Framework at the end of the annual development cycle.

Submitting a Change Proposal to a Final Text Change Proposal or a Final Text Supplement is not possible.

655 The current version of the Technical Framework is considered the primary reference document. Final Text Supplements and Final Text Change Proposals from the current annual cycle complement this document. Past Final Text documents are retained to provide convenient summaries of differences to prior versions of the Technical Framework or Trial Implementation versions of Supplements.

660 During the annual development and maintenance cycle, it is recommended to use Technical Framework documents for implementations as follows:

- Product Implementations

665 Products implemented based on Trial Implementation text are expected to review the subsequent Final Text and update their products as necessary. Further, it is expected that vendors will monitor Final Text Change Proposals and make any corrections relevant to their product in a timely fashion.

- Connectathon Implementations

670 Testing at the Connectathon will be based on the current version of the Technical Framework for the appropriate IHE Domain, plus any relevant Supplements for Trial Implementation and Final Text Change Proposals.

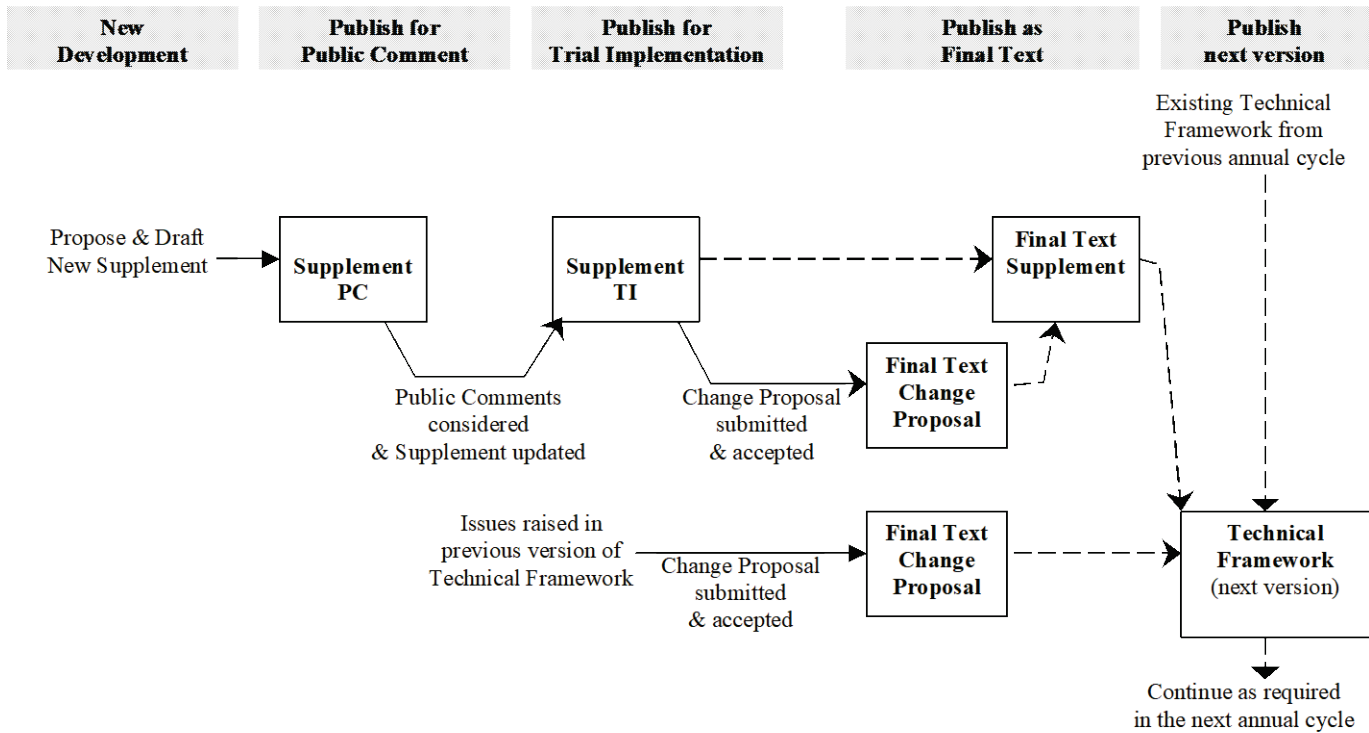

Figure 1.10-1: The figure shows the process of developing and maintaining the Technical Framework during an annual cycle. Dashed arrows indicate the assembly (merging) of text.

675

2 Integration Profiles

IHE Integration Profiles, depicted in Figure 2-1, offer a common language that healthcare professionals and vendors may use in communicating requirements for the integration of products. Integration Profiles describe real-world scenarios or specific sets of capabilities of integrated systems. An Integration Profile applies to a specified set of actors and for each actor specifies the transactions necessary to support those capabilities.

Integration Profiles provide a convenient way for both users and vendors to reference a subset of the functionality detailed in the IHE Technical Framework. They enable users and vendors to be more specific than simply requesting or promising overall IHE support, without laborious restatement of the details regarding IHE actors and transactions defined by the IHE Technical Framework.

The Profiles can be considered in three classes: Content Profiles which address the management of a particular type of content object; Workflow Profiles which address the management of the workflow process by which content is created; and Infrastructure Profiles which address departmental issues. Figure 2-1 shows the current set of IHE Integration Profiles organized around these classes.

The Content Profiles describe the creation, storage, management, retrieval and general use of a particular type of content object. Current Content Profiles include: Consistent Presentation of Images, Key Image Notes, NM Image, Mammography Image, Evidence Documents, and Simple Image and Numeric Reports. Additionally, the handling of image content is described inside the Scheduled Workflow Profile. Content Profiles are “workflow neutral”. The profile addresses how the object is created, stored, queried and retrieved, but does not address the workflow management process.

The Workflow Profiles address managing workflow process, which typically involves providing worklists, and reporting/monitoring the progress and completion of workitems. Within this context, one or more content objects are generally created according to their content profile. Current Workflow Profiles include: Scheduled Workflow (for acquisition), Post-Processing Workflow, Reporting Workflow, Cross-enterprise Document Sharing for Imaging and Import Reconciliation Workflow. Presentation of Grouped Procedures is an extension of Scheduled Workflow. Charge Posting is an extension of all the Workflow Profiles.

The Infrastructure Profiles address general departmental issues like Radiology Audit Trail Option and Access to Radiology Information.

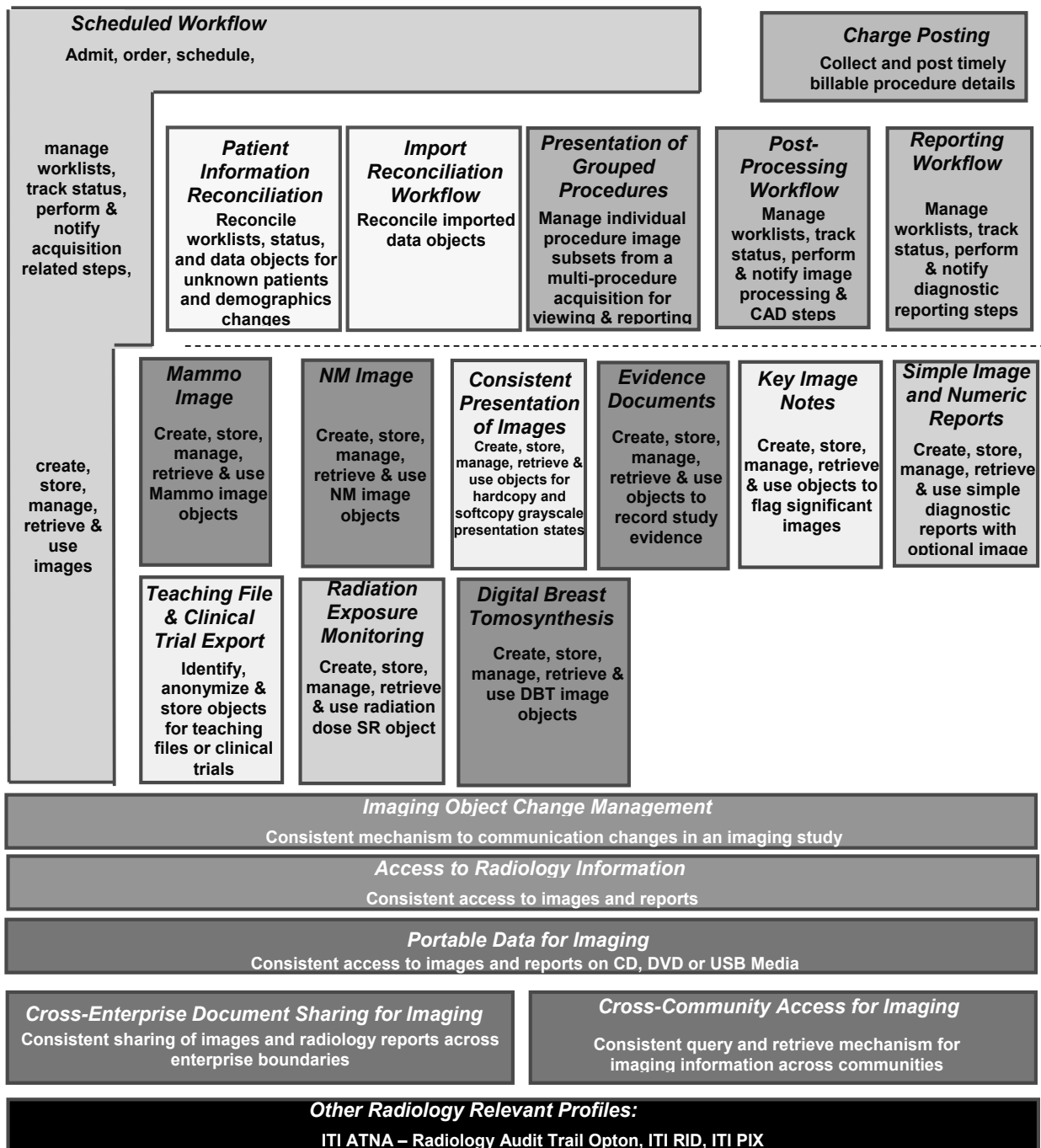

Figure 2-1: IHE Integration Profiles

710 **Dependencies among Integration Profiles**

In general, IHE Integration Profiles do not operate independently. Objects that serve as useful input to one profile may have been produced as a result of implementing another profile.

Figure 2-1 (above) provides a graphical view of the dependencies between integration profiles. Table 2-1 defines the required dependencies between the integration profiles in a tabular form.

715 In some cases a profile is strictly dependent on one or more profiles in order to function. For example, Presentation of Grouped Procedures depends directly on the features of Scheduled Workflow and Consistent Presentation of Images in order to function.

720 In other cases a profile is dependent on one of a class of profiles in order to be useful. For example, Charge Posting depends on at least one of the workflow profiles (Scheduled Workflow, Post-Processing Workflow and/or Reporting Workflow) being present in order for it to have something useful to post. Similarly, each workflow profile is of little value unless at least one relevant content profile is also implemented. Of course the more content profiles are supported, the more forms of input and output can be managed by the workflow.

725 There are of course other useful synergies that occur when different combinations of profiles are implemented, but those are not described in the table below.

Table 2-1: Integration Profiles Dependencies

Integration Profile	Depends on	Dependency Type	Comments
Consistent Presentation of Images	<i>None</i>	<i>None</i>	-
Key Image Notes	<i>None</i>	<i>None</i>	-
NM Image	<i>None</i>	<i>None</i>	
Mammography Image	<i>None</i>	<i>None</i>	
Evidence Documents	<i>None</i>	<i>None</i>	-
Simple Image and Numeric Report	<i>None</i>	<i>None</i>	-
Access to Radiology Information	One or more of : {Scheduled Workflow Consistent Presentation of Images, Evidence Documents, Key Image Notes, Simple Image and Numeric Reports} Patient Information Reconciliation	Required for Content output Conditionally Required for the Multi Source Option	Supporting the image related transactions of Scheduled Workflow counts as a content profile
Scheduled Workflow	<i>None</i>	<i>None</i>	-
Presentation of Grouped Procedures	Scheduled Workflow	Required for workflow	-
	Consistent Presentation of Images	Required for Content output	-
Post-Processing Workflow	Scheduled Workflow	Required for workflow management	-
	One or more of: {Scheduled Workflow, Evidence Documents, NM Image}	Required for Content input	Supporting the image related transactions of Scheduled Workflow counts as a content profile

IHE Radiology Technical Framework, Volume 1 (RAD TF-1): Integration Profiles

Integration Profile	Depends on	Dependency Type	Comments
	One or more of : {Scheduled Workflow Consistent Presentation of Images, Evidence Documents, Key Image Notes}	Required if any output is produced	Supporting the image related transactions of Scheduled Workflow counts as a content profile
Reporting Workflow	Scheduled Workflow	Required for workflow management	-
	One or more of: {Scheduled Workflow, Evidence Documents, NM Image}	Required for Content input	Supporting the image related transactions of Scheduled Workflow counts as a content profile.
	Simple Image and Numeric Reports	Required for Content input/output	-
Charge Posting	One or More of : {Scheduled Workflow, Post-Processing Workflow, Reporting Workflow, Import Reconciliation Workflow}	Required for charge trigger input	-
Patient Information Reconciliation	Scheduled Workflow	Required for workflow/content to manage	Patient Information Reconciliation is an extension to this profile requiring that the workitems and/or content be updated.
Portable Data for Imaging	<i>None</i>	<i>None</i>	-
XDS for Imaging (XDS-I.b)	XDS.b (ITI)	Document Consumer, Document Registry, and Document Repository actors from ITI XDS.b are needed to support the transactions and workflows defined by XDS-I.b.	Document content types and metadata are specialized.
	ATNA, incl. Radiology Audit Trail Option	Each XDS-I.b Actor shall be grouped with the Secure Node or Secure Application Actor.	Required to manage audit trail of exported PHI, node authentication and transport encryption.
Import Reconciliation Workflow	Scheduled Workflow	Required for Workflow (including Scheduled Import Option)	Support the workflow related transactions of Scheduled Workflow.
	Patient Demographics Query [ITI]	Required for Unscheduled Import Option	Patient Demographic information is obtained using Patient Demographic Query.
Teaching File and Clinical Trial Export	<i>None</i>	<i>None</i>	-

IHE Radiology Technical Framework, Volume 1 (RAD TF-1): Integration Profiles

Integration Profile	Depends on	Dependency Type	Comments
Radiation Exposure Monitoring	<i>None</i>	<i>None</i>	-
Cross-Community Access for Imaging (XCA-I)	XDS.b (ITI)	Required for access of documents	
	XCA (ITI)	Required for cross community access of documents	
	Audit Trail and Node Authentication, incl. Radiology Audit Trail Option	Each XCA-I Actor shall be grouped with Secure Node Actor or Secure Application	Required to manage audit trail of exported PHI, node authentication and transport encryption.
	Consistent Time (ITI)	Each XCA-I Actor shall be grouped with the Time Client Actor.	To ensure consistency among document and submission set dates.
Imaging Object Change Management	Scheduled Workflow	Required for workflow management	Defines how Image Manager/Image Archive can obtain scheduled worklist in order to correct the modality worklist selection of the acquired instances. Support communication of procedure steps and storage commitment when Change Requester is grouped with Acquisition Modality, Image Manager/Image Archive or Evidence Creator. Support Image Manager to Image Manager change management if Multiple Patient Identity Resolution Option is supported.
	Patient Information Reconciliation	Required for reconciliation workflow	Support the patient information reconciliation mechanisms for the actor that is grouped with the Change Requester.
Digital Breast Tomosynthesis	<i>None</i>	<i>None</i>	-

730 Vendor products support an Integration Profile by implementing the appropriate actor-transactions as outlined in the Integration Profile in Sections 3-40. A product may implement more than one actor and more than one Integration Profile.

An actor must implement all required transactions in the pre-requisite profiles in addition to those in the desired profile. In some cases, the pre-requisite is that the actor selects any one of a given set of profiles to satisfy the pre-requisite. For example, Post-processing depends on any one of the content profiles being supported.

735 Actors (see Section 2.3) are information systems or components of information systems that produce, manage, or act on information associated with operational activities in the enterprise.

Transactions (see Section 2.4) are interactions between actors that transfer the required information through standards-based messages.

2.1 Integration Profiles Overview

740 In this document, each IHE Integration Profile is defined by:

- The IHE actors involved
- The specific set of IHE Transactions required for each IHE actor.

745 These requirements are presented in the form of a table of transactions required for each actor supporting the Integration Profile. Actors supporting multiple Integration Profiles are required to support all the required transactions of each Integration Profile supported. When an Integration Profile depends upon another Integration Profile, all transactions required for the dependent Integration Profile have been included in the table.

750 As mentioned earlier, there is a class of Profiles that deal primarily with data content. Most types of content belong to the family of Evidence Objects. Currently this means Images, Presentation States, Key Image Notes and Evidence Documents. Evidence Objects are generated as a result of performing procedure steps on systems in the radiology department. These objects are used by the Radiologist in the process of creating a Radiological Diagnostic Report and are managed inside the Radiology Department. Evidence Documents represent the uninterpreted information that is primarily managed and used inside Radiology, although distribution outside Radiology is not precluded. In contrast, the diagnostic reports described in the Simple Image and Numeric Reports Profile represent the interpreted information which is the primary output of the Radiology department and are available for wide distribution.

760 Note that IHE Integration Profiles are not statements of conformance to standards, and IHE is not a certifying body. Users should continue to request that vendors provide statements of their conformance to relevant standards, such as DICOM and HL7. Standards conformance is a prerequisite for vendors adopting IHE Integration Profiles.

Also note that there are critical needs for any successful integration project that IHE cannot address. Successfully integrating systems still requires a project plan that minimizes disruptions and describes fail-safe strategies, specific and mutually understood performance expectations,

765 well-defined user interface requirements, clearly identified systems limitations, detailed cost
objectives, plans for maintenance and support, etc.

2.1.1 Scheduled Workflow (SWF)

770 The Scheduled Workflow Integration Profile establishes the continuity and integrity of basic
departmental imaging data acquired in an environment where examinations are generally being
ordered. It specifies a number of transactions that maintain the consistency of patient and
ordering information as well as defining the scheduling and imaging acquisition procedure steps.
775 This profile also makes it possible to determine whether images and other evidence objects
associated with a particular performed procedure step have been stored (archived) and are
available to enable subsequent workflow steps, such as reporting. It may also provide central
coordination of the completion of processing and reporting steps as well as notification of
appointments to the Order Placer.

2.1.2 Patient Information Reconciliation (PIR)

780 The Patient Information Reconciliation Integration Profile extends the *Scheduled Workflow
Integration Profile* by offering the means to match images, diagnostic reports, and other
evidence objects acquired for a misidentified or unidentified patient (for example, during a
trauma case) with the patient's record. In the example of the trauma case, this integration profile
allows subsequent reconciliation of the patient record with images that are acquired (either
without a prior registration or under a generic registration) before the patient's identity could be
determined. Thus images, diagnostic reports and other evidence objects can be acquired and
785 interpreted immediately and later, when the patient's official registration and order information
is entered into the ADT, Order Placer and Order Filler Systems, this information is matched with
the acquired image set, greatly simplifying these exception-handling situations.

2.1.3 Consistent Presentation of Images (CPI)

790 The Consistent Presentation of Images Integration Profile specifies a number of transactions that
maintain the consistency of presentation for grayscale images and their presentation state
information (including user annotations, shutters, flip/rotate, display area, and zoom). It also
defines a standard contrast curve, the Grayscale Standard Display Function, against which
different types of display and hardcopy output devices can be calibrated. It thus supports
hardcopy, softcopy and mixed environments.

2.1.4 Presentation of Grouped Procedures (PGP)

795 The Presentation of Grouped Procedures Integration Profile (PGP) addresses what is sometimes
referred to as the linked studies problem: viewing image subsets resulting from a single
acquisition with each image subset related to a different requested procedure (e.g., CT chest,
abdomen and pelvis). It provides a mechanism for facilitating workflow when viewing images
800 and reporting on individual requested procedures that an operator has grouped (often for the sake
of acquisition efficiency and patient comfort). A single acquired image set is produced, but the
combined use of the scheduled workflow transactions and the consistent presentation of images

allow separate viewing and interpretation of the image subsets related to each of the requested procedures.

805 **2.1.5 Access to Radiology Information (ARI)**

The Access to Radiology Information Integration Profile specifies a number of query transactions providing access to radiology information, including images and related reports, in a DICOM format as they were acquired or created. Such access is useful both to the radiology department and to other departments such as pathology, surgery and oncology.

810 **2.1.6 Key Image Note (KIN)**

The Key Image Note Integration Profile specifies transactions that allow a user to mark one or more images in a study as significant by attaching to them a note managed together with the study. This note includes a title stating the purpose of marking the images and a user comment field. Physicians may attach Key Image Notes to images for a variety of purposes: referring
815 physician access, teaching files selection, consultation with other departments, and image quality issues, etc.

2.1.7 Simple Image and Numeric Report (SINR)

The Simple Image and Numeric Report Integration Profile facilitates the growing use of digital dictation, voice recognition, and specialized reporting packages, by separating the functions of
820 reporting into discrete actors for creation, management, storage and viewing. Separating these functions while defining transactions to exchange the reports between them enables a vendor to include one or more of these functions in an actual system.

2.1.8 Basic Security (SEC) - DEPRECATED

This profile has been superseded by the ITI Audit Trail and Node Authentication (ATNA)
825 Integration Profile and the Radiology Audit Trail Option on ATNA. See Sections 2.2.1 and 10 for details on backward compatibility of this option and the Basic Security Profile.

2.1.9 Charge Posting (CHG)

The Charge Posting Integration Profile specifies the exchange of information from the
830 Department System Scheduler/Order Filler Actor to the Charge Processor Actor regarding charges associated with particular procedures, as well as communication between the ADT/Patient Registration and Charge Processor Actors about patient demographics, accounts, insurance, and guarantors. The Charge Posted Transaction contains all of the required procedure data to generate a claim. Currently, these interfaces contain fixed field formatted or HL7-style data. The goal of including this transaction in the Radiology Technical Framework is to
835 standardize the Charge Posted Transaction to a Charge Processor, thus reducing system interface installation time between clinical systems and Charge Processors. Additionally, the Charge Posted Transaction reduces the need of the billing system to have knowledge of the radiology internals. The result is that the Charge Processor will receive more complete, timely and accurate data.

840 **2.1.10 Post-Processing Workflow (PWF)**

The Post-Processing Workflow Integration Profile addresses the need to schedule, distribute and track the status of typical post-processing workflow steps, such as Computer-Aided Detection or Image Processing. Worklists for each of these tasks are generated and can be queried, workitems can be selected and the resulting status returned from the system performing the work to the system managing the work. **IMPORTANT NOTE: As of June 2012, IHE introduces a new Trial Implementation Profile: Post-Acquisition Workflow (PAWF). The use cases addressed are largely the same as PWF, but the underlying mechanisms are improved. The PWF Profile documented in this section has been deprecated by the Radiology Domain and is now replaced by PAWF. When the PAWF Profile becomes Final Text, the contents of Section 10 will be removed. In the interim, new implementations should be based on PAWF, found at http://ihe.net/Technical_Frameworks/#radiology.**

845

850

2.1.11 Reporting Workflow (RWF)

The Reporting Workflow Profile addresses the need to schedule, distribute and track the status of the reporting workflow tasks such as interpretation, transcription and verification. Worklists for each of these tasks are generated and can be queried; workitems can be selected and the resulting status returned from the system performing the work to the system managing the work.

855

2.1.12 Evidence Documents (ED)

The Evidence Documents Profile defines interoperable ways for observations, measurements, results and other procedure details recorded in the course of carrying out a procedure step to be output by devices, such as acquisition systems and other workstations; to be stored and managed by archival systems; and to be retrieved and presented by display and reporting systems. This allows detailed non-image information, such as measurements, CAD results, procedure logs, etc. to be made available as input to the process of generating a diagnostic report. The Evidence Documents may be used either as additional evidence for the reporting physician or in some cases for selected items in the Evidence Document to be included in the diagnostic report.

860

865

2.1.13 Portable Data for Imaging (PDI)

The Portable Data for Imaging Integration Profile specifies actors and transactions that allow users to distribute imaging related information on interchange media. The intent of this profile is to provide reliable interchange of evidence objects and diagnostic reports for import, display or print by a receiving actor. The CD format with uncompressed content was chosen as the baseline. Options for the support of DVD media and USB, JPEG and JPEG 2000 lossless and lossy compression on CD, DVD and USB media are also defined.

870

2.1.14 NM Image (NMI)

The NM Image Integration Profile specifies how Acquisition Modalities and workstations should store NM Images and how Image Displays should retrieve and make use of them. It defines the basic display capabilities Image Displays are expected to provide, and also how result screens,

875

both static and dynamic, such as those created by NM Cardiac Processing Packages, should be stored using DICOM objects that can be displayed on general purpose Image Display systems.

2.1.15 Teaching File and Clinical Trial Export (TCE)

880 The Teaching File and Clinical Trial Export Profile addresses the need to select DICOM instances, series or studies (which may contain images, key image notes, reports, evidence documents and presentation states) that need to be exported for teaching files or clinical trials.

It defines an actor for making the Export Selection, which would typically be grouped with an Image Display or Acquisition Modality, and an actor for processing the selection, which is
885 required to support a configurable means of de-identifying the exported instances. Additional options are provided for de-identification of pixel data, remapping of identifiers to pseudonymous values, export of additional teaching file information, and delaying export for a variety of reasons.

2.1.16 Cross-Enterprise Document Sharing for Imaging (XDS-I.b)

890 The Cross-Enterprise Document Sharing for Imaging (XDS-I.b) Integration Profile specifies actors and transactions that allow users to share imaging information across enterprises. This profile depends on the IHE IT Infrastructure Cross-Enterprise Document Sharing (XDS.b) Profile. Cross-Enterprise Document Sharing for Imaging (XDS-I.b) defines the information to be
895 shared such as sets of DICOM instances (including images, evidence documents, and presentation states), diagnostic imaging reports provided in a ready-for-display format.

Since the XDS-I.b Profile depends on and extends the IT Infrastructure XDS.b Profile including the use of terms defined in XDS (e.g., XDS Affinity Domain, submission set, etc.) the reader of XDS-I.b is expected to have read and understood the XDS Profile.

2.1.17 Mammography Image (MAMMO)

900 The Mammography Image Profile specifies how DICOM Mammography images and evidence objects are created, exchanged and used. It describes how Acquisition Modalities transfer Full Field Digital Mammography (FFDM) Images, how CAD systems act as Evidence Creators, and how Image Displays should retrieve and make use of images and CAD results. It defines the basic display capabilities Image Displays are expected to provide, and which attributes should be
905 used to implement those capabilities.

2.1.18 Image Fusion (FUS)

This section intentionally, temporarily left blank.

2.1.19 Import Reconciliation Workflow (IRWF)

910 The Import Reconciliation Workflow Integration Profile (IRWF) specifies how data Importers obtain local demographics, coerce patient and procedure attribute values in the imported data and report progress/status of the importation process. The Profile complements the Scheduled Workflow Profile by using the existing workflow mechanisms for notification and storage of

imported Evidence Objects. **IMPORTANT NOTE:** *As of June 2012, IHE introduces an updated Import Reconciliation Profile (IRWF.b) for Trial Implementation. In addition to the original use cases, several new use cases are addressed, and the underlying mechanisms are improved. The IRWF Profile documented in this section has been deprecated by the Radiology Domain and is now replaced by the IRWF.b. When that supplement becomes Final Text, the contents of Section 21 will be removed. In the interim, new implementations should be based on IRWF.b, found at http://www.ihe.net/Technical_Frameworks/#radiology.*

920 **2.1.20 Radiation Exposure Monitoring (REM)**

The Radiation Exposure Monitoring Integration Profile specifies communications between systems generating reports of irradiation events (generally acquisition modalities and workstations) and systems which receive, store, or process those reports (generally local dose information management systems and/or national/regional dose registries). It defines how DICOM SR objects for CT and projection X-ray dose objects are created, stored, queried, retrieved, de-identified, and may be processed and displayed.

2.1.21 Mammography Acquisition Workflow (MAWF)

This section intentionally, temporarily left blank.

2.1.22 MR Diffusion Imaging (DIFF)

930 This section intentionally, temporarily left blank.

2.1.23 CT/MR Perfusion Imaging with Contrast (PERF)

This section intentionally, temporarily left blank.

2.1.24 Basic Image Review (BIR)

This section intentionally, temporarily left blank.

935 **2.1.25 Chest X-Ray CAD Display (CXCAD)**

This section intentionally, temporarily left blank.

2.1.26 Imaging Object Change Management (IOCM)

940 The Imaging Object Change Management Integration Profile (IOCM) specifies how one actor communicates local changes applied on existing imaging objects to other actors that manage copies of the modified imaging objects in their own local systems. The supported changes include (1) object rejection due to quality or patient safety reasons, (2) correction of incorrect modality worklist entry selection, and (3) expiration of objects due to data retention requirements. It defines how changes are captured and how to communicate these changes.

2.1.27 Cross-Community Access for Imaging (XCA-I)

945 The Cross-Community Access for Imaging (XCA-I) Integration Profile specifies actors and transactions to query and retrieve patient-relevant medical imaging data being held by other communities.

Within a community, a group of facilities/enterprises shares clinical information via an established mechanism such as XDS-I (in which case the community can be referred to as an XDS Affinity Domain). This profile addresses sharing between such communities.

The XCA-I Profile extends the IT Infrastructure XCA Profile. XCA provides access to Diagnostic reports and Imaging Manifests. XCA-I provides access to the imaging objects referenced in the Manifests. The reader of XCA-I is expected to have read and understood the XCA Profile, including the meaning of terms such as Community, homeCommunityId, etc.

2.1.28 Post Acquisition Workflow (PAWF)

This section intentionally, temporarily left blank.

2.1.29 Cross-Enterprise Document Reliable Interchange of Images (XDR-I)

This section intentionally, temporarily left blank.

2.1.30 Stereotactic Mammography Image (SMI)

960 This section intentionally, temporarily left blank.

2.1.31 Management of Radiology Report Templates (MRRT)

This section intentionally, temporarily left blank.

2.1.32 Scheduled Workflow.b (SWF.b)

This section intentionally, temporarily left blank.

2.1.33 Invoke Image Display (IID)

This section intentionally, temporarily left blank.

2.1.34 Intentionally Left Blank

This section was previously reserved for the Mobile access to Health Documents for Imaging (MHD-I) Profile. That profile was deprecated in 2017 and replaced with the Web-based Image Access (WIA) Profile.

2.1.35 Digital Breast Tomosynthesis (DBT)

The Digital Breast Tomosynthesis (DBT) Profile specifies the creation, exchange and use of DBT images. It defines basic display capabilities that Image Displays are expected to provide, especially simultaneous review of DBT and conventional 2D mammography images (FFDM).

975 The Digital Breast Tomosynthesis Profile is designed to provide faithful storage and retrieval of DBT images. Furthermore, sufficient display functionality to allow adequate review of current and prior studies consisting of DBT and/or conventional 2D mammography images is defined. The support for CAD is out of the scope for this profile.

2.1.36 Web-based Image Capture (WIC)

980 This section intentionally, temporarily left blank.

2.1.37 Clinical Decision Support – Order Accountable Tracking (CDS-OAT)

This section intentionally, temporarily left blank.

2.1.38 Radiation Exposure Monitoring – Nuclear Medicine (REM-NM)

This section intentionally, temporarily left blank.

985 **2.1.39 Cross-Enterprise Remote Read Workflow Definition (XRR-WD)**

This section intentionally, temporarily left blank.

2.1.40 Web-based Image Access (WIA)

This section intentionally, temporarily left blank.

2.1.41 Standardized Operational Log Events (SOLE)

990 This section intentionally, temporarily left blank.

2.1.42 Management of Acquisition Protocols (MAP)

This section intentionally, temporarily left blank.

2.1.43 Results Distribution (RD)

This section intentionally, temporarily left blank.

995 **2.1.44 Intentionally Left Blank**

This section is intentionally left blank.

2.1.45 Encounter-based Imaging Workflow (EBIW)

This section intentionally, temporarily left blank.

2.1.46 Import and Display of External Priors (IDEP)

1000 This section intentionally, temporarily left blank.

2.2 Options to other Domains' Profiles

2.2.1 ITI-Audit Trail and Node Authentication

1005 The Radiology Audit Trail Option is an option on the ITI Audit Trail and Node Authentication (ATNA) Profile. The ITI-ATNA Profile provides security and privacy mechanisms like a common audit trail and authentication for distributed applications. Refer to the ATNA Profile (ITI TF-1: 9) for the full definition of this profile.

1010 The Radiology Audit Trail Option deals largely with the details of the Record Audit Event transaction in the IHE ITI Technical Framework. It defines audit events on IHE Radiology transactions for a Secure Node. This option does not extend the Authenticate Node transaction in the ATNA Profile.

2.3 Actor Descriptions

1015 Actors are information systems or components of information systems that produce, manage, or act on information associated with operational activities in the enterprise. The following are the actors defined by IHE and referenced throughout the rest of this document.

1020 It is acknowledged that some of the terms used as modifiers for the actor names are not used consistently (e.g., Evidence Creator, Image Display). At this point, the benefit in doing extensive renaming to gain consistency is outweighed by the risk of introducing significant confusion that would result from renaming many of the existing actors. Therefore, the actor names will remain as defined below.

1025 **Acquisition Modality** – A system that acquires and creates medical images while a patient is present, e.g., a Computed Tomography scanner or Nuclear Medicine camera. A modality may also create other evidence objects such as Grayscale Softcopy Presentation States for the consistent viewing of images or Evidence Documents containing measurements. A modality may also create and store Dose SRs.

ADT Patient Registration – A system responsible for adding and/or updating patient demographic and encounter information. In particular, it registers a new patient with the Order Placer and Department System.

1030 **Charge Processor** – Receives the posted charges and serves as a component of the financial system. Further definition of this actor is beyond current IHE scope.

Change Requester – A system that communicates changes to an Image Manager / Archive, indicating that certain imaging instances should be deleted. In addition, it may also send new versions of these imaging instances containing corrected information.

1035 **Department System Scheduler/Order Filler** – A department-based information system (for instance, Radiology or Laboratory) that provides functions related to the management of orders received from external systems or through the department system's user interface. Upon a defined workflow action, makes procedures available for charge posting. The action/event that actually causes charges to post is defined by the actor.

- 1040 **Display** – Primary description for this actor can be found in ITI TF-1: Appendix A. The required capabilities for its use within the Radiology Technical Framework add the ability to view "web-viewable" diagnostic and therapeutic imaging information on interchange media.
- Document Consumer** – The Document Consumer Actor queries a Document Registry Actor for documents meeting certain criteria, and retrieves selected documents from one or more Document Repository Actors.
- 1045 **Document Registry** – The Document Registry Actor maintains meta-data about each registered document in a document entry. This includes a link to the Document Repository where the actual document is stored. The Document Registry responds to queries from Document Consumer Actors about documents meeting specific criteria. It also enforces some healthcare specific technical policies at the time of document registration.
- 1050 **Document Repository** – The Document Repository Actor persistently stores documents. It assigns and maintains a unique identifier for each document, to allow Document Consumers to retrieve them.
- Dose Information Consumer** – Responsible for supplemental handling of irradiation events, generally on an individual basis (e.g., display, analysis, or further processing).
- 1055 **Dose Information Reporter** – Responsible for the aggregation, analysis, reporting and business logic related to irradiation events, which may include meeting facility obligations to de-identify and submit data to various dose registries.
- Dose Registry** – Collates information about irradiation events from a number of facilities, generally to perform analysis.
- 1060 **Enterprise Report Repository** – A system that receives Structured Report Export Transactions from the Report Manager and stores them.
- Evidence Creator** – A system that creates additional evidence objects such as images, presentation states, Key Image Notes, and/or Evidence Documents and transmits them to an Image Archive. It also makes requests for storage commitment to the Image Manager for the data previously transmitted. It may also retrieve worklist entries for post-processing steps from the Post-Processing Manager and provide notification of completion of the step, allowing the enterprise to track the status of post-processing work.
- 1065 **Export Manager** – A system that can de-identify and pseudonymize the attributes, and optionally the pixel data, of a selected list of instances, before exporting them.
- 1070 **Export Selector** – A system that allows a user to select one or more instances, series or studies for export, for a specific purpose, with a specific disposition, optionally with the inclusion of additional information.
- External Report Repository Access** – A system that performs retrieval of clinical reports containing information generated outside the imaging department and presented as DICOM Structured Reporting Objects.
- 1075 **Image Archive** – A system that provides long term storage of evidence objects such as images, presentation states, Key Image Notes, Evidence Documents and Dose SR.

- 1080 **Image Display** – A part of a system that can access imaging evidence objects (images, Presentation States, Key Image Notes, Evidence Documents) through network query/retrieve or reading interchange media and allow the user to view these objects.
- Image Manager** – A system that provides functions related to safe storage and management of evidence objects. It supplies availability information for those objects to the Department System Scheduler. It also accepts/commits dose data and supports query/retrieve.
- 1085 **Imaging Document Consumer** – The Imaging Document Consumer Actor parses an imaging manifest document that is retrieved by the Document Consumer Actor from the Document Repository Actor, and retrieves DICOM SOP Instances referenced within that manifest from the Imaging Document Source Actor.
- 1090 **Imaging Document Source** – The Imaging Document Source Actor is the producer and publisher of imaging documents. It is responsible for providing imaging documents and meta-data to the Document Repository Actor, which subsequently registers the imaging documents with the Document Registry Actor. It also supports the retrieval services for DICOM SOP Instances referenced in a published imaging manifest document.
- Importer** – A system that imports evidence objects such as images, presentation states, Key Image Notes or Evidence Documents from hardcopy or digital media.
- 1095 **Master Patient Index (MPI)** – A system that maintains unique enterprise-wide identifiers for patients. Note that this is not supported in the current scope of the IHE Technical Framework
- Order Placer** – A hospital or enterprise-wide system that generates orders for various departments and distributes those orders to the correct department.
- 1100 **Patient Demographics Supplier** – A repository of patient information that can be searched on demographic related fields. This actor is defined in the ITI Technical Framework.
- Performed Procedure Step Manager** – A system that re-distributes the Modality Performed Procedure Step information from the Acquisition Modality or Evidence Creator to the Department System Scheduler/Order Filler, Image Manager and Report Manager.
- 1105 **Portable Media Creator** – This actor assembles the content of the media and writes it to the physical medium.
- Portable Media Importer** – This actor reads the DICOM information contained on the media, and allows the user to select DICOM instances, reconcile key patient and study attributes, and store these instances. The actor grouped with the Media Importer can then process the instances.
- 1110 **Post-Processing Manager** – A system that provides functions related to post-processing worklist management. This involves the ability to schedule post-processing worklist items (scheduled procedure steps), provide worklist items to post-processing worklist clients, and update the status of scheduled and performed procedure steps as received from post-processing worklist clients.
- 1115 **Print Composer** – A system that generates DICOM print requests to the Print Server. Print requests include presentation state information in the form of Presentation Look-Up Tables (Presentation LUTs). It may also read the DICOM information contained on interchange media.

Print Server – A system that accepts and processes DICOM print requests as a DICOM Print SCP and performs image rendering on hardcopy media. The system must support pixel rendering according to the DICOM Grayscale Standard Display Function.

1120 **Receiver** – A system that can receive exported instances over the network, whose behavior is otherwise unspecified unless grouped with other actors.

Report Creator – A system that generates and transmits draft (and optionally, final) diagnostic reports, presenting them as DICOM Structured Reporting Objects. It may also retrieve worklist entries for reporting steps from the Report Manager and provide notification of completion of the step, allowing the enterprise to track the status of an awaited report.

1125 **Report Manager** – A system that provides management and short-term storage of DICOM Structured Report objects during the reporting process then distributes text or structured reports to report repositories. It also manages the worklists and status of reporting.

Report Reader – A part of a system that can access reports through network query/retrieve or reading interchange media and allow the user to view reports presented as DICOM Structured Reporting Objects.

1130 **Report Repository** – A system that provides long-term storage of diagnostic reports and their retrieval as DICOM Structured Reporting Objects.

Initiating Imaging Gateway – The Initiating Imaging Gateway Actor proxies Imaging Document Set Retrieve requests from an Image Document Consumer to a Responding Imaging Gateway with a Cross Gateway Retrieve Imaging Document Set transaction.

Responding Imaging Gateway – The responding Imaging Gateway proxies Cross Gateway Retrieve Imaging Document Set requests from an Initiating Imaging Gateway to an Imaging Document Source with an Image Document Set Retrieve request.

1140 2.4 Transaction Descriptions

Transactions are interactions between actors that transfer the required information through standards-based messages. The following are the transactions defined by IHE and referenced throughout the rest of this document.

1. **Patient Registration** – The ADT system registers and/or admits a patient and forwards the information to other information systems.
- 1145 2. **Placer Order Management** – The Order Placer informs the Order Filler of the initiation or cancellation of an order. The Placer/Filler Order Management transaction will sometimes be referred to as “-New” when a new order is being initiated, or as “-Cancel” when an existing order is canceled.
- 1150 3. **Filler Order Management** – The Order Filler informs the Order Placer of the initiation, cancellation, or change in the status of an order. The Placer/Filler Order Management transaction will sometimes be referred to as “-New” when a new order is being initiated, or as “-Cancel” when an existing order is canceled.
- 1155 4. **Procedure Scheduled** – Schedule information is sent from the Department System Scheduler/Order Filler to the Image Manager and to the Report Manager.

5. **Query Modality Worklist** – In response to a query (with optional filtering) a list of Scheduled Procedure Steps with selected demographic and order information is returned.
- 1160 6. **Modality Procedure Step In Progress** – An Acquisition Modality notifies the Performed Procedure Step Manager of the start of a new Procedure Step and the PPS Manager informs the Department System, Image Manager and the Report Manager.
7. **Modality Procedure Step Completed** – An Acquisition Modality notifies the Performed Procedure Step Manager of the completion of a Procedure Step and the PPS Manager informs the Department System, Image Manager and the Report Manager.
- 1165 8. **Modality Images Stored** – An Acquisition Modality sends acquired or generated images to the Image Archive.
9. **Modality Presentation State Stored** – An Acquisition Modality requests that the Image Archive store a Grayscale Softcopy Presentation State (GSPS) for the acquired or generated images.
- 1170 10. **Storage Commitment** – Request and receive from an actor which has stored DICOM objects (such as images or Evidence Documents) confirmation of receipt and ownership for the specified objects, generally to allow the requesting actor to safely delete those objects.
11. **Images Availability Query** – The Department System Scheduler/Order Filler and Report Manager asks the Image Manager if a particular image or image series is available.
- 1175 12. **Patient Update** – The ADT Patient Registration System informs the Order Placer and the Department System Scheduler/Order Filler of new information for a particular patient. The Department System Scheduler may then further inform the Image Manager and Report Manager.
13. **Procedure Update** – The Department System Scheduler/Order Filler sends the Image Manager and Report Manager updated order or procedure information.
- 1180 14. **Query Images** – An Image Display queries the Image Archive for a list of entries representing images by patient, study, series, or instance.
15. **Query Presentation States** – An Image Display queries the Image Archive for a list of entries representing image Grayscale Softcopy Presentation States (GSPS) by patient, study, series, or instance.
- 1185 16. **Retrieve Images** – An Image Display or an Imaging Document Consumer requests and retrieves a particular image or set of images from the Image Archive or an Imaging Document Source, respectively.
17. **Retrieve Presentation States** – An Image Display or an Imaging Document Consumer requests and retrieves the Grayscale Softcopy Presentation State (GSPS) information for a particular image or image set.
- 1190 18. **Creator Images Stored** – An Evidence Creator sends new images to the Image Archive.
19. **Creator Presentation State Stored** – An Evidence Creator requests that the Image Archive store the created Grayscale Softcopy Presentation State objects.
20. **Creator Procedure Step In Progress** – An Evidence Creator notifies the Performed Procedure Step Manager of the start of a new Procedure Step and the PPS Manager informs the Department System and Image Manager.
- 1195 21. **Creator Procedure Step Completed** – An Evidence Creator notifies the Performed Procedure Step Manager of the completion of a Procedure Step and the PPS Manager informs the Department System and Image Manager.

- 1200 22. **Intentionally unassigned**
23. **Print Request with Presentation LUT** – A Print Composer sends a print request to the Print Server specifying Presentation LUT information.
24. **Report Submission** – A Report Creator sends a draft or final diagnostic report to the Report Manager.
- 1205 25. **Report Issuing** – A Report Manager sends a draft or final diagnostic report to the Report Repository.
26. **Query Reports** – A Report Reader provides a set of criteria to select the list of entries representing diagnostic reports by patient, study, series, or instance known by the Report Repository or External Report Repository Access.
- 1210 27. **Retrieve Reports** – A Report Reader or an Imaging Document Consumer requests and retrieves a diagnostic report from the Report Repository, External Report Repository Access or an Imaging Document Source.
28. **Structured Report Export** – A Report Manager composes an HL7 Result transaction by mapping from DICOM SR and transmits it to the Enterprise Report Repository for storage.
- 1215 29. **Key Image Note Stored** – An Acquisition Modality or an Evidence Creator sends a Key Image Note to the Image Archive
30. **Query Key Image Notes** – An Image Display queries the Image Archive for a list of entries representing Key Image Notes by patient, study, series, or instance.
31. **Retrieve Key Image Note** – An Image Display or an Imaging Document Consumer requests and retrieves a Key Image Note from the Image Archive or an Imaging Document Source, respectively.
- 1220 32. **Authenticate Node [DEPRECATED]** – This transaction is identical to, and has been superseded by the Authenticate Node [ITI-19] transaction as part of the ITI Audit Trail and Node Authentication Profile (ITI TF-1: 3.19).
- 1225 33. **Maintain Time [DEPRECATED]** – This transaction identical to, and has been superseded by the Maintain Time as part of the ITI Consistent Time Profile (ITI TF-2a: 3.1).
34. **Record Audit Event [DEPRECATED]** – This transaction has been superseded by the Record Audit Event as part of the ITI Audit Trail and Node Authentication Profile (ITI TF-2a: 3.20).
- 1230 35. **Charge Posted** - The Department System Scheduler/Order Filler sends descriptions of potential procedure and material charges.
36. **Account Management** – The ADT Patient Registration Actor informs the Charge Processor about creation, modification and ending of the patient’s account.
- 1235 37. **Query Post-Processing Worklist** – Based on a query from a worklist client (Evidence Creator), a worklist is generated by the worklist manager (Post-Processing Manager) containing either Post-Processing or Computer Aided Detection (CAD) workitems that satisfy the query. Workitems are returned in the form of a list of General Purpose Scheduled Procedure Steps.
- 1240 38. **Workitem Claimed** – A worklist client (Evidence Creator, Report Creator) notifies the worklist provider (Post-Processing Manager, Report Manager) that it has claimed the workitem.

39. **Workitem PPS In Progress** – A worklist client (Evidence Creator, Report Creator) notifies the worklist provider (Post-Processing Manager, Report Manager) that it has started work (i.e., created a General Purpose Performed Procedure Step).
- 1245 40. **Workitem PPS Completed** – A worklist client (Evidence Creator, Report Creator) notifies the worklist provider (Post-Processing Manager, Report Manager) of the completion of a General Purpose Performed Procedure Step.
41. **Workitem Completed** – A worklist client (Evidence Creator, Report Creator) notifies the worklist provider (Post-Processing Manager, Report Manager) that it has finished the workitem (i.e., completed a General Purpose Scheduled Procedure Step).
- 1250 42. **Performed Work Status Update** – The worklist provider informs other interested actors of the on-going status and completion of performed work.
43. **Evidence Document Stored** – A source actor of Evidence Documents (Acquisition Modality or Evidence Creator) sends recorded, measured or derived diagnostic evidence in the form of a DICOM Structured Report to the Image Archive.
- 1255 44. **Query Evidence Documents** – A user of Evidence Documents (Image Display, Report Creator or Report Reader) queries the Image Archive for a list of entries representing Evidence Documents.
45. **Retrieve Evidence Documents** – A user of Evidence Documents (Image Display, Report Creator or Report Reader) or an Imaging Document Consumer requests and retrieves an Evidence Document from the Image Archive or an Imaging Document Source, respectively.
- 1260 46. **Query Reporting Worklist** – Based on a query from a Report Creator worklist client, a worklist is generated by the Report Manager containing reporting task workitems that satisfy the query. Workitems are returned in the form of a list of General Purpose Scheduled Procedure Steps.
- 1265 47. **Distribute Imaging Information on Media** – A source actor (Portable Media Creator) writes image data, other evidence objects and reports onto a piece of interchange media. The media is physically transported to another actor (Portable Media Importer, Image Display, Report Reader, Display or Print Composer) which then imports, displays or prints the evidence objects and reports. The media can also be provided to a patient or a referring physician for web-based viewing.
- 1270 48. **Appointment Notification** – The Department System Scheduler/Order Filler sends the Order Placer Actor the date and time of the appointment(s) related to one or more Scheduled Procedure Step(s).
- 1275 49. **Instance Availability Notification** – The Image Manager/Image Archive notifies interested workflow actors (such as the Department System Scheduler/Order Filler, Post-Processing Manager and Report Manager) about the availability status of instances at specified storage locations.
- 1280 50. **Store Instances** – An Export Selector sends to an Export Manager instances that are to be de-identified, pseudonymized and exported.
51. **Store Export Selection** – An Export Selector sends to an Export Manager an instance of a Key Object Selection Document that references a list of instances that are to be de-identified, pseudonymized and exported.

- 1285 52. **Store Additional Teaching File Information** – An Export Selector sends to an Export Manager instances containing additional information about the instances that are to be exported.
53. **Export Instances** – An Export Manager sends to a Receiver instances that have been exported.
- 1290 54. **Provide and Register Imaging Document Set [DEPRECATED]** - This transaction has been deprecated and is superseded by the Provide and Register Imaging Document Set – MTOM/XOP Transaction (RAD TF-3: 4.68) as part of the Cross-Enterprise Document Sharing for Imaging (XDS-I.b) Profile.
- 1295 55. **WADO Retrieve** – A WADO Retrieve transaction is issued by an Imaging Document Consumer to an Imaging Document Source to retrieve DICOM objects over HTTP/HTTPS protocol [RAD-55].
56. **Intentionally, temporarily Left Blank**
57. **Intentionally, temporarily Left Blank**
58. **Intentionally, temporarily Left Blank**
- 1300 59. **Import Procedure Step In Progress** – The Performed Procedure Step Manager receives progress notification of an importation Procedure Step and in turn notifies the Order Filler, Image Manager and the Report Manager.
60. **Import Procedure Step Completed** – The Performed Procedure Step Manager receives completion notification of an importation Procedure Step and in turn notifies the Order Filler, Image Manager and the Report Manager.
- 1305 61. **Imported Objects Stored** – A system importing DICOM Objects or digitized hardcopy sends imported DICOM Composite Objects to the Image Archive.
62. **Store Dose Information** – Send details of Irradiation Events encoded in DICOM SR using DICOM Store.
- 1310 63. **Submit Dose Information** – Send details of Irradiation Events encoded in DICOM SR using secure FTP.
64. **Query Dose Information** – Obtain a list of references to Dose objects matching a given filter.
65. **Retrieve Dose Information** – Obtain specific Dose objects containing descriptions of Irradiation Events.
- 1315 66. **Rejection Note Stored** – Create and send a manifest referencing images that are rejected for quality or patient safety reasons, rejected for incorrect modality worklist selection, or deleted due to data retention expiration. The manifest can be used to hide or provide rejected images later in routine use, based on specific configuration.
- 1320 67. **Intentionally, temporarily Left Blank**
68. **Provide and Register Imaging Document Set – MTOM/XOP** – An Imaging Document Source Actor uses the Provide and Register Imaging Document Set Transaction to submit documents with associated metadata to a Document Repository. [RAD-68] specializes [ITI-41].
- 1325 69. **Retrieve Imaging Document Set** – An Imaging Document Consumer Actor uses this Transaction to issue a web service request to retrieve a set of DICOM instances. [RAD-69] specializes [ITI-43].
70. **Intentionally, temporarily Left Blank**

71. **Intentionally, temporarily Left Blank**

72. **Intentionally, temporarily Left Blank**

1330 73. **Intentionally, temporarily Left Blank**

74. **Replacement Instances Stored** – A Change Requester send new updated instances with corrected header information to an Image Manager/Image Archive.

75. **Cross Gateway Retrieve Imaging Document Set** – An Initiating Imaging Gateway sends a request for an Imaging Document Set to a Responding Imaging Gateway.

1335 **2.5 Product Implementations**

Developers have a number of options in implementing IHE actors and transactions in product implementations. The decisions cover four levels of optionality:

- For a system, select which actors it will incorporate. (Multiple actors per system is acceptable).

1340 • For each actor, select which Integration Profiles it will participate in.

- For each actor-profile, select which optional transactions will be implemented. All required transactions must be implemented for the profile to be supported. (Refer to the Integration Profile Tables in Sections 3 and later.)

1345 • Finally, for each transaction, select which optional features will be supported. (Refer to the transaction descriptions in RAD TF Volume 2 and Volume 3)

Implementers should provide a statement describing which IHE actors, IHE Integration Profiles, optional transactions and optional features are incorporated in a given product. The recommended form for such a statement is defined in Appendix D.

1350 In general, a product implementation may incorporate any single actor or combination of actors. However, in the cases specified below, the implementation of one actor requires the implementation of one or more additional actors:

- The Image Archive in any Radiology profile shall be grouped with the Image Manager, and the Image Manager shall be grouped with the Image Archive.

1355 • The Image Manager participating in Scheduled Workflow or Reporting Workflow Integration Profiles shall be grouped with a Performed Procedure Step Manager. The grouped Performed Procedure Step Manager shall be capable of being disabled via configuration.

1360 • The Department System Scheduler/Order Filler participating in any of the following profiles, Scheduled Workflow, Patient Information Reconciliation, Charge Posting, Presentation of Grouped Procedures, Import Reconciliation Workflow, or Reporting Workflow, shall be grouped with a Performed Procedure Step Manager. The grouped Performed Procedure Step Manager shall be capable of being disabled via configuration.

- The Print Composer in any Radiology profile shall be grouped with an Image Manager, an Acquisition Modality, an Image Display or an Evidence Creator.

- 1365
- The Evidence Creator participating in Post-Processing Workflow shall be grouped with an Image Display from one or more Radiology profiles.
 - A Radiology Profile Actor which is grouped with a Secure Node Actor or Secure Application Actor of the ITI Audit Trail and Node Authentication Integration Profile (ITI TF-1: 9.4) shall support the applicable Radiology events and semantics defined in RAD TF-3: 5.1.
- 1370
- The Post-Processing Manager in the Post-Processing Workflow Profile shall be grouped with either an Image Manager or a Department System Scheduler.
 - The Portable Media Importer in the Portable Data for Imaging Profile shall be grouped with at least one of the following actors from one or more Radiology profiles in order to perform import of the supported evidence objects and/or Diagnostic Reports:
- 1375
- Evidence Creator (Evidence Documents)
 - Acquisition Modality (Images, Key Image Notes, Evidence Documents)
 - Image Manager/Image Archive (Images, Presentation States, Key Image Notes, Evidence Documents)
- 1380
- Report Creator (Diagnostic Reports)
 - Report Manager (Diagnostic Reports)
 - Report Repository (Diagnostic Reports)
 - Importer
- 1385
- The Imaging Document Consumer shall be grouped with an ITI XDS.b Document Consumer, thereby supporting the Document Consumer's transactions for querying a Document Registry and retrieving from a Document Repository as defined in the ITI XDS.b Profile.
 - The Importer Actor in the Import Reconciliation Workflow Profile is generic in terms of not defining a specific transport mechanism for the Evidence Objects it imports. It may be necessary for the Importer to be grouped with additional Actors to support specific transport mechanisms. For example, to support import from PDI Media, the Importer Actor must be grouped with the Portable Media Importer Actor.
- 1390
- The Change Requester is generic in terms of not defining a specific mechanism for obtaining the original instances that it requests changes to. It shall be grouped with at least one of the following actors in order to obtain the original instances:
- 1395
- Evidence Creator
 - Acquisition Modality
 - Image Manager/Image Archive

1400 When multiple actors are grouped in a single product implementation, all transactions originating or terminating with each of the supported actors shall be supported (i.e., the IHE transactions shall be offered on an external product interface). The exceptions to this rule are any transactions defined between actors in the required groupings defined above.

1405 For example, the Procedure Step In Progress/Completed transaction does not need to be supported between the Performed Procedure Step Manager and the Image Manager when these are grouped together in a single system. On the other hand, the Report Submission Transaction must be supported even by an implementation that groups the Report Creator and the Report Manager.

1410 When two or more actors are grouped together, internal communication between actors is assumed to be sufficient to allow the necessary information flow to support their functionality; for example, the Image Manager provides necessary information updates to the Image Archive to support its Query/Retrieve functionality. The exact mechanisms of such internal communication are outside the scope of the IHE Technical Framework.

1415 The following examples describe which actor's typical systems might be expected to support. This is not intended to be a requirement, but rather to provide some examples to aid understanding.

- A modality system, such as an MRI scanner and console or Ultrasound system might typically include an Acquisition Modality Actor and a Print Composer Actor.
- An imaging workstation, such as a post-processing workstation or advanced review station might typically include an Image Display Actor, an Evidence Creator Actor and a Print Composer Actor.
- A HIS registration and order entry system might typically include the ADT Patient Registration Actor and an Order Placer Actor.
- A departmental RIS system might typically include a Department System Scheduler Actor, an Order Filler Actor, a Performed Procedure Step Manager Actor, a Report Manager Actor and a Report Reader Actor.
- An Ultrasound system that generates echo report measurements would likely include an Acquisition Modality Actor that supports both the Scheduled Workflow Profiles and the Evidence Documents Profile.

1430 When an implementation has an actor supporting multiple integration profiles, the actor is required to support logical cross-behaviors/ transactions. For example, if an Evidence Creator supports the Post-Processing Workflow and Evidence Documents Profiles, then the actor must generate PPS messages when creating evidence documents. If an Image Display supports the Simple Image and Numeric Reports and Consistent Presentation of Images Profiles, then the actor must make use of any GSPS referenced by the Simple Image and Numeric Report when rendering the relevant images.

1435 If an implementation supports the Consistent Presentation of Images Integration Profile with both an Image Display and a Print Composer, both actors shall support calibration against the

1440 Grayscale Softcopy Display Function, in a consistent manner across both actors. In addition, the combined actors must perform the image data manipulations necessary to match the presentation of the Hardcopy with the Softcopy presentations.

1445 If an implementation includes a Print Composer in combination with an Image Manager, Acquisition Modality, or Evidence Creator (and not an Image Display), then it is recommended but not required that the Print Composer calibrate its display system. In addition, the Print Composer must be able to perform the image data manipulations specified by the Grayscale Softcopy Presentation State that is related to the image.

3 Scheduled Workflow (SWF)

1450 The *Scheduled Workflow Integration Profile* establishes the continuity and integrity of basic departmental imaging data. It specifies a number of transactions that maintain the consistency of patient and ordering information as well as providing the scheduling and imaging acquisition procedure steps. This profile also makes it possible to determine whether images and other evidence objects associated with a particular performed procedure step have been stored (archived) and are available to enable subsequent workflow steps, such as reporting. It may also provide central coordination of the completion of processing and reporting steps as well as notification of appointments to the Order Placer.

1455 **3.1 Actors/Transactions**

Figure 3.1-1 diagrams the actors involved with this profile and the transactions between actors.

Note: In an attempt to simplify Figure 3.1-1, not all of the “optional” transactions listed in Table 3.1-1 are shown in the diagram.

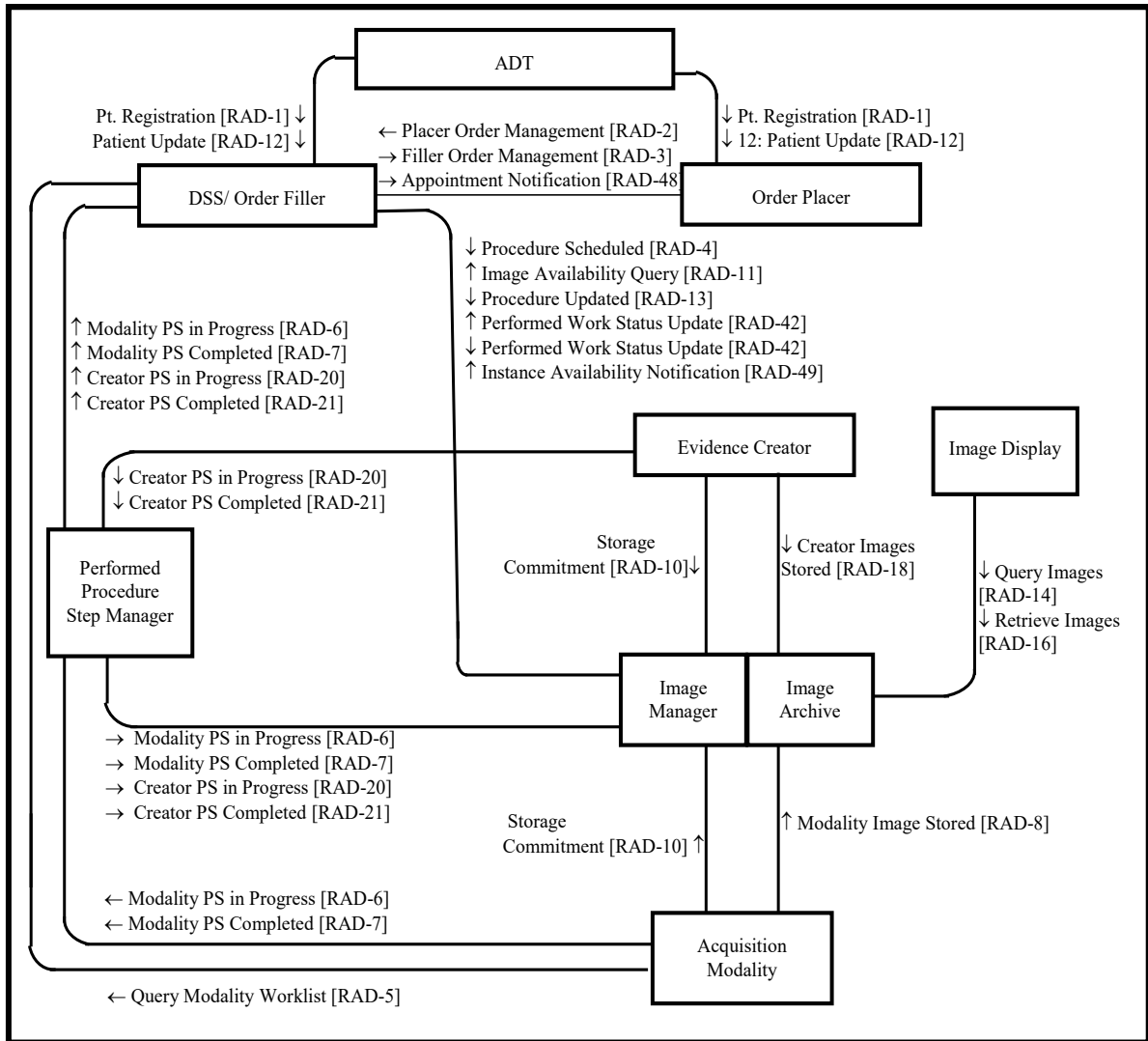

1460

Figure 3.1-1: Scheduled Workflow Diagram

Table 3.1-1 lists the transactions for each actor directly involved in the Scheduled Workflow Integration Profile. In order to claim support of this Integration Profile, an implementation must perform the required transactions (labeled “R”). Transactions labeled “O” are optional. A complete list of options defined by this Integration Profile that implementations may choose to support is listed in Section 3.2.

1465

Table 3.1-1: Scheduled Workflow - Actors and Transactions

Actors	Transactions	Optionality	TF Reference
ADT Patient Registration	Patient Registration [RAD-1]	R	RAD TF-2: 4.1
	Patient Update [RAD-12]	R	RAD TF-2: 4.12
Order Placer	Patient Registration [RAD-1]	R	RAD TF-2: 4.1
	Patient Update [RAD-12]	R	RAD TF-2: 4.12
	Placer Order Management [RAD-2]	R	RAD TF-2: 4.2
	Filler Order Management [RAD-3]	R	RAD TF-2: 4.3
	Appointment Notification [RAD-48]	O	RAD TF-3: 4.48
Department System Scheduler/ Order Filler	Patient Registration [RAD-1]	R	RAD TF-2: 4.1
	Patient Update [RAD-12]	R	RAD TF-2: 4.12
	Placer Order Management [RAD-2]	R	RAD TF-2: 4.2
	Filler Order Management [RAD-3]	R	RAD TF-2: 4.3
	Procedure Scheduled [RAD-4]	R	RAD TF-2: 4.4
	Query Modality Worklist [RAD-5]	R	RAD TF-2: 4.5
	Modality Procedure Step In Progress [RAD-6]	R	RAD TF-2: 4.6
	Modality Procedure Step Completed [RAD-7]	R	RAD TF-2: 4.7
	Images Availability Query [RAD-11]	O	RAD TF-2: 4.11
	Procedure Updated [RAD-13]	R	RAD TF-2: 4.13
	Creator Procedure Step in Progress [RAD-20]	R	RAD TF-2: 4.20
	Creator Procedure Step Completed [RAD-21]	R	RAD TF-2: 4.21
	Performed Work Status Update [RAD-42] (as the Receiver, see Note 1))	O	RAD TF-3: 4.42
	Appointment Notification [RAD-48]	O	RAD TF-3: 4.48
	Instance Availability Notification [RAD-49]	O	RAD TF-3: 4.49
Acquisition Modality	Query Modality Worklist [RAD-5]	R	RAD TF-2: 4.5
	Modality Procedure Step In Progress [RAD-6]	R	RAD TF-2: 4.6
	Modality Procedure Step Completed [RAD-7]	R	RAD TF-2: 4.7
	Modality Images Stored [RAD-8]	R	RAD TF-2: 4.8
	Storage Commitment [RAD-10]	R	RAD TF-2: 4.10
Image Manager/ Image Archive	Procedure Scheduled [RAD-4]	R	RAD TF-2: 4.4
	Modality Procedure Step In Progress [RAD-6]	R	RAD TF-2: 4.6
	Modality Procedure Step Completed [RAD-7]	R	RAD TF-2: 4.7

Actors	Transactions	Optionality	TF Reference
	Modality Images Stored [RAD-8]	R	RAD TF-2: 4.8
	Storage Commitment [RAD-10]	R	RAD TF-2: 4.10
	Images Availability Query [RAD-11]	R	RAD TF-2: 4.11
	Procedure Updated [RAD-13]	R	RAD TF-2: 4.13
	Query Images [RAD-14]	R	RAD TF-2: 4.14
	Retrieve Images [RAD-16]	R	RAD TF-2: 4.16
	Creator Images Stored [RAD-18]	R	RAD TF-2: 4.18
	Creator Procedure Step in Progress [RAD-20]	R	RAD TF-2: 4.20
	Creator Procedure Step Completed [RAD-21]	R	RAD TF-2: 4.21
	Performed Work Status Update [RAD-42] (as the Receiver, see Note 1)	O	RAD TF-3: 4.42
Instance Availability Notification [RAD-49]	O	RAD TF-3: 4.49	
Performed Procedure Step Manager	Modality Procedure Step In Progress [RAD-6]	R	RAD TF-2: 4.6
	Modality Procedure Step Completed [RAD-7]	R	RAD TF-2: 4.7
	Creator Procedure Step in Progress [RAD-20]	R	RAD TF-2: 4.20
	Creator Procedure Step Completed [RAD-21]	R	RAD TF-2: 4.21
Image Display	Query Images [RAD-14]	R	RAD TF-2: 4.14
	Retrieve Images [RAD-16]	R	RAD TF-2: 4.16
Evidence Creator	Creator Images Stored [RAD-18]	R	RAD TF-2: 4.18
	Creator Procedure Step in Progress [RAD-20]	O	RAD TF-2: 4.20
	Creator Procedure Step Completed [RAD-21]	O	RAD TF-2: 4.21
	Storage Commitment [RAD-10]	R	RAD TF-2: 4.10

Note 1: The Department System Scheduler or the Image Manger may optionally choose to be receivers of Performed Work Status Update transactions in order to monitor the status of work in workflows that are managed by other systems (see RAD TF-3: 4.42).

1470

Refer to Table 2-1 for other profiles that may be pre-requisites for this profile.

3.2 Scheduled Workflow Integration Profile Options

Options that may be selected for this Integration Profile are listed in the Table 3.2-1 along with the Actors to which they apply. Dependencies between options when applicable are specified in notes.

1475

Table 3.2-1: Scheduled Workflow - Actors and Options

Actor	Option	TF Reference
ADT Patient Registration	HL7 v2.5.1	RAD TF-1: 3.2.1 RAD TF-2: 4.1 RAD TF-2: 4.12
Order Placer	Departmental Appointment Notification	RAD TF-3: 4.48
	HL7 v2.5.1	RAD TF-1: 3.2.1 RAD TF-1: 3.3.3.2 RAD TF-2: 4.1 RAD TF-2: 4.2 RAD TF-2: 4.3 RAD TF-2: 4.12
DSS/Order Filler	Image Availability	RAD TF-2: 4.11
	Departmental Appointment Notification	RAD TF-3: 4.48
	PPS Exception Management	RAD TF-2: 4.7
	Performed Work Status Update - Receive	RAD TF-2: 4.42
	Availability of PPS-Referenced Instances	RAD TF-3: 4.49
	HL7 v2.5.1	RAD TF-1: 3.2.1 RAD TF-1: 3.3.3.2 RAD TF-2: 4.1 RAD TF-2: 4.2 RAD TF-2: 4.3 RAD TF-2: 4.4 RAD TF-2: 4.12 RAD TF-2: 4.13
Acquisition Modality	Patient Based Worklist Query (Note 1)	RAD TF-2: 4.5
	Broad Worklist Query (Note 1)	RAD TF-2: 4.5
	Assisted Acquisition Protocol Setting	RAD TF-2: 4.6
	PPS Exception Management	RAD TF-2: 4.7
	Modality Group Case (Note 2)	RAD TF-2: 4.6
	Billing and Material Management	RAD TF-2: 4.7
Image Manager/ Image Archive	Availability of PPS-Referenced Instances	RAD TF-3: 4.49
	PPS Exception Management	RAD TF-2: 4.7
	Performed Work Status Update - Receive	RAD TF-2: 4.42
	HL7 v2.5.1	RAD TF-1: 3.2.1 RAD TF-2: 4.4 RAD TF-2: 4.13
Image Display	<i>No options defined</i>	-
Performed Procedure Step Manager	<i>No options defined</i>	-
Evidence Creator	Creator Performed Procedure Step	RAD TF-2: 4.20 RAD TF-2: 4.21
	PPS Exception Management (Note 3)	RAD TF-2: 4.21

Note 1: At least one of these two options is required. Both may be supported.

Note 2: When a modality claims support for the Modality Group Case Option, it is required to support all three grouping scenarios described in RAD TF-2: 4.6.4.1.2.3.4.

1480

Note 3: An Evidence Creator claiming the PPS Exception Management Option shall also support the Creator Performed Procedure Step Option.

The Evidence Creator, Acquisition Modality and Image Manager/ Image Archive will likely support a variety of DICOM SOP Classes. It is expected that this level of optionality will be documented by a reference in the IHE Integration Statement (see Appendix D).

1485

3.2.1 HL7 v2.5.1 Option

The HL7 v2.5.1 Option requires actors to support HL7 v2.5.1 in addition to HL7 v2.3.1 in the transactions referenced in Table 3.2-1. The actor shall permit configuration for each system that it communicates with using the referenced transactions whether HL7 v2.3.1 or HL7 v2.5.1 is used. It is possible that the actor may receive HL7 v2.3.1 messages and send HL7 v2.5.1

1490

messages or vice versa.

The specifications in the HL7 v2.5.1 Option maintain semantic equivalency with HL7 v2.3.1 implementations and the field correspondences are summarized in RAD TF-2: Appendix E.

3.3 Scheduled Workflow Process Flow

1495

This section describes the process and information flow of patient care as it is defined in the Radiology Technical Framework under “normal” circumstances. It covers transactions [RAD-1] through [RAD-12] and transaction [RAD-23], which reflect a typical patient encounter from registration/admission through the performance of an ordered procedure. See Appendix C for an overview of the information exchange between the Department System Scheduler/Order Filler and Image Manager.

1500

To support the Scheduled Workflow Profile, an actor that claims support of other content profiles (Consistent Presentation of Images, Key Image Notes or Evidence Documents) is required to support the relevant storage, query and retrieve transactions and manage creation of those objects in the same way images are supported. The following diagrams will mostly show the management of images.

1505

3.3.1 Administrative and Procedure Performance Process Flow

This case covers both inpatient and outpatient procedures. The patient may be new or known to the current healthcare facility. The following sequence of steps describes the typical process flow when a request is made to perform an imaging procedure on a patient.

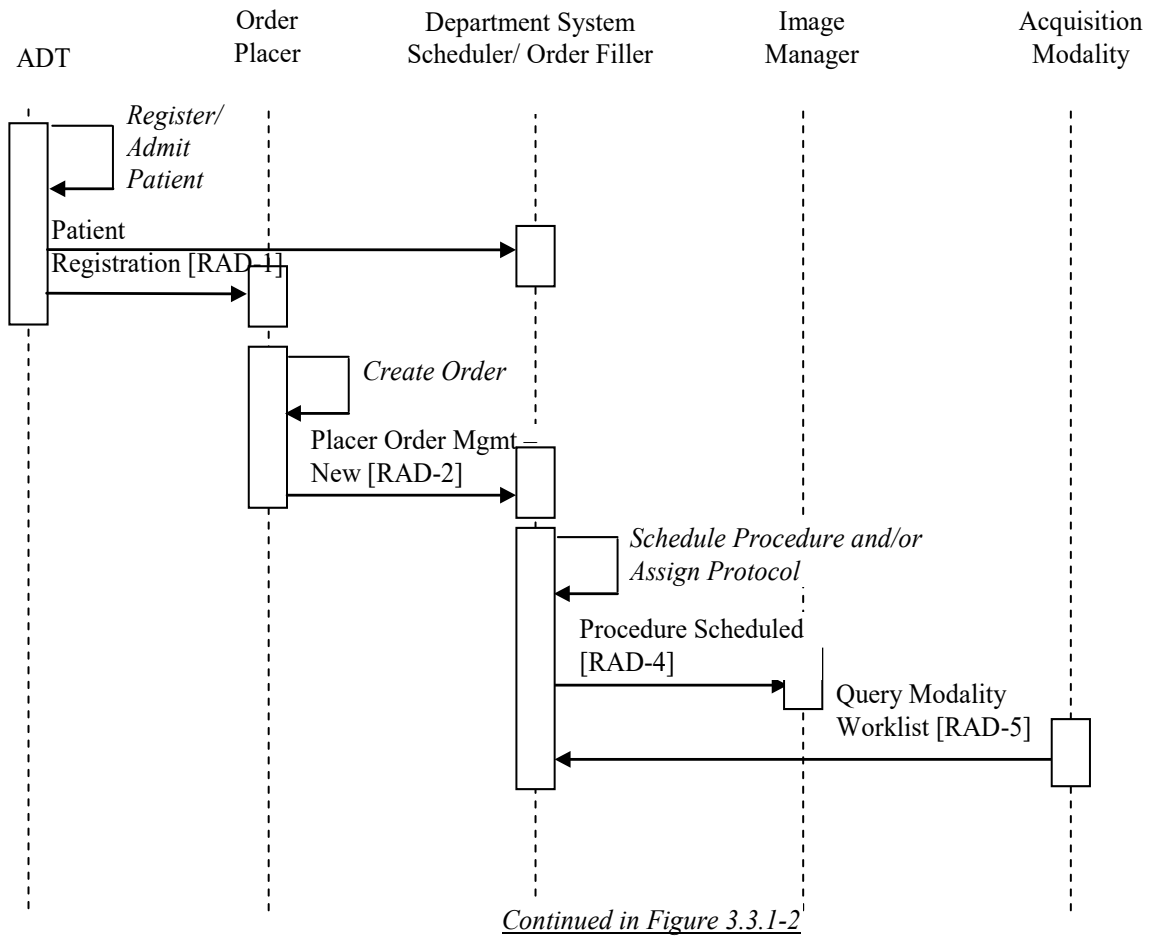

1510

Figure 3.3.1-1: Administrative Process Flow

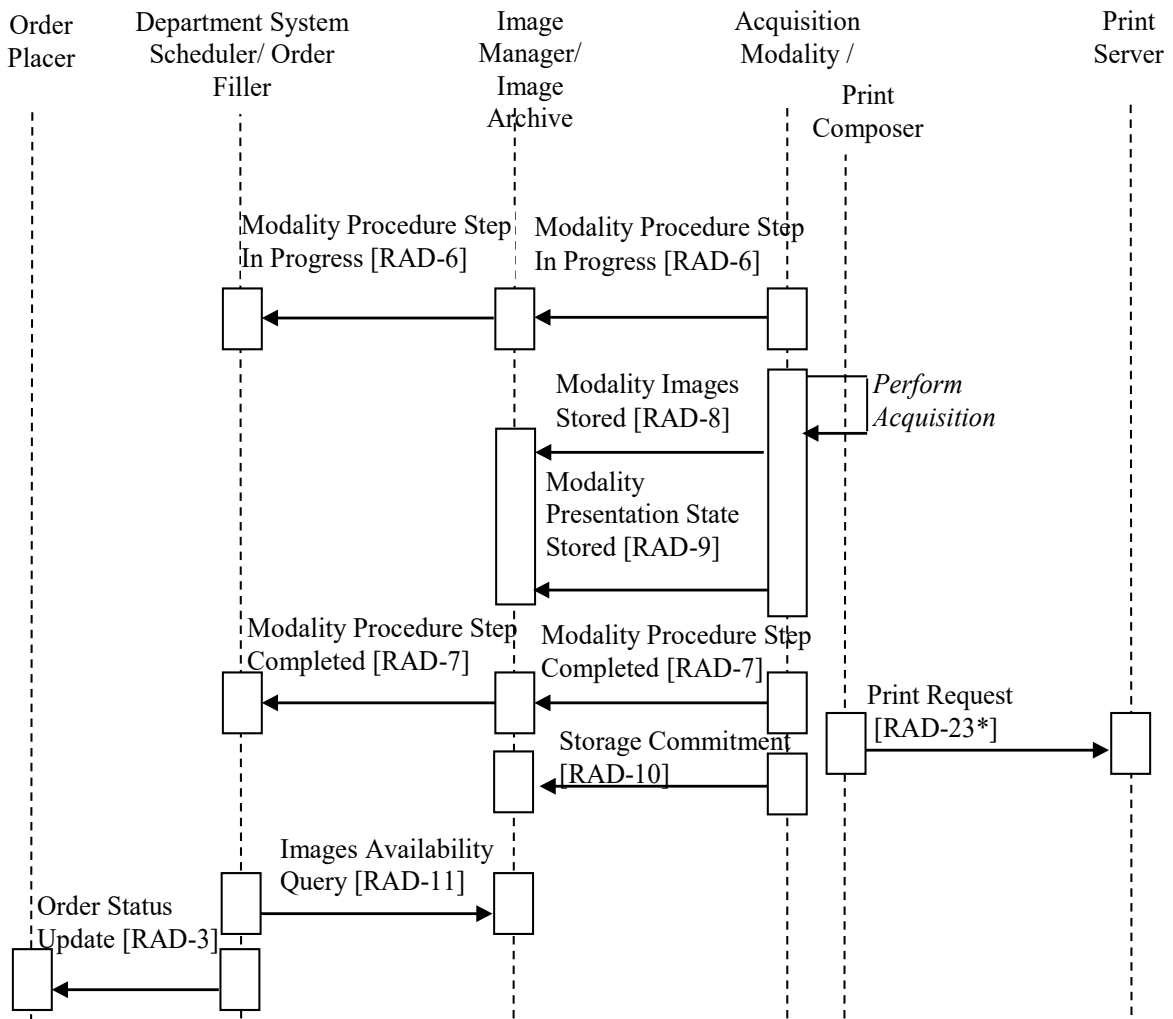

Figure 3.3.1-2: Procedure Performance Process Flow

Note: The Print Request [RAD-23] transaction is not a part of this profile; it is displayed for illustration purposes only.

1515 The following should be noted in relation to the Administrative and Procedure Performance process flow:

- The Print Composer is grouped with an Acquisition Modality but is shown separately in the diagram to distinguish the different transactions.

1520 *Schedule Procedure*: The Department System associates the order with a number of Requested Procedures that have to be performed to satisfy the order. Each Requested Procedure prescribes a number of actions that have to be performed by Acquisition Modalities. Actions are grouped into Scheduled Procedure Steps based on the timing and ordering. Scheduled Procedure Steps are scheduled, i.e., assigned a time slot and performing resource (modality).

- 1525 • *Protocol Assigned*: The radiologist determines the protocol (i.e., settings and conditions to be used in performing the Scheduled Procedure Steps); in particular, the ordered list of codes identifying the protocol for each of the steps. This may happen prior to, simultaneous with, or subsequent to the *Schedule Procedure* process step.
- 1530 • The diagram above shows one particular sequencing of the Modality Procedure Step Completed [RAD-7] transaction. This transaction may occur at any point following the creation of an image and/or Presentation State (GSPS) objects. This means it can occur before images and/or GSPS are stored, after storage, after printing (as in this example), or even after storage commitment. The Radiology Technical Framework does not specify the timing of this transaction in relation to other transactions.
- 1535 • The diagram above shows the managed creation of images. The equivalent flow applies to other Evidence Documents that the actor supports.

3.3.2 Patient Update Flow

1540 This case covers the situation where patient information updates are introduced into the system at the various stages of the normal process flow. Such updates will cause additional transactions to occur to assure synchronization of information between interested actors. Only the affected parts of the normal flow diagram are presented below. All subsequent process steps will progress according to the normal flow diagram.

3.3.2.1 Patient Update before Procedure Scheduling

1545 If patient information is changed before the corresponding procedure(s) are scheduled by the Department System Scheduler/Order Filler, the Patient Registration steps are altered as presented in the Figures 3.3.2.1-1 and 3.3.2.1-2.

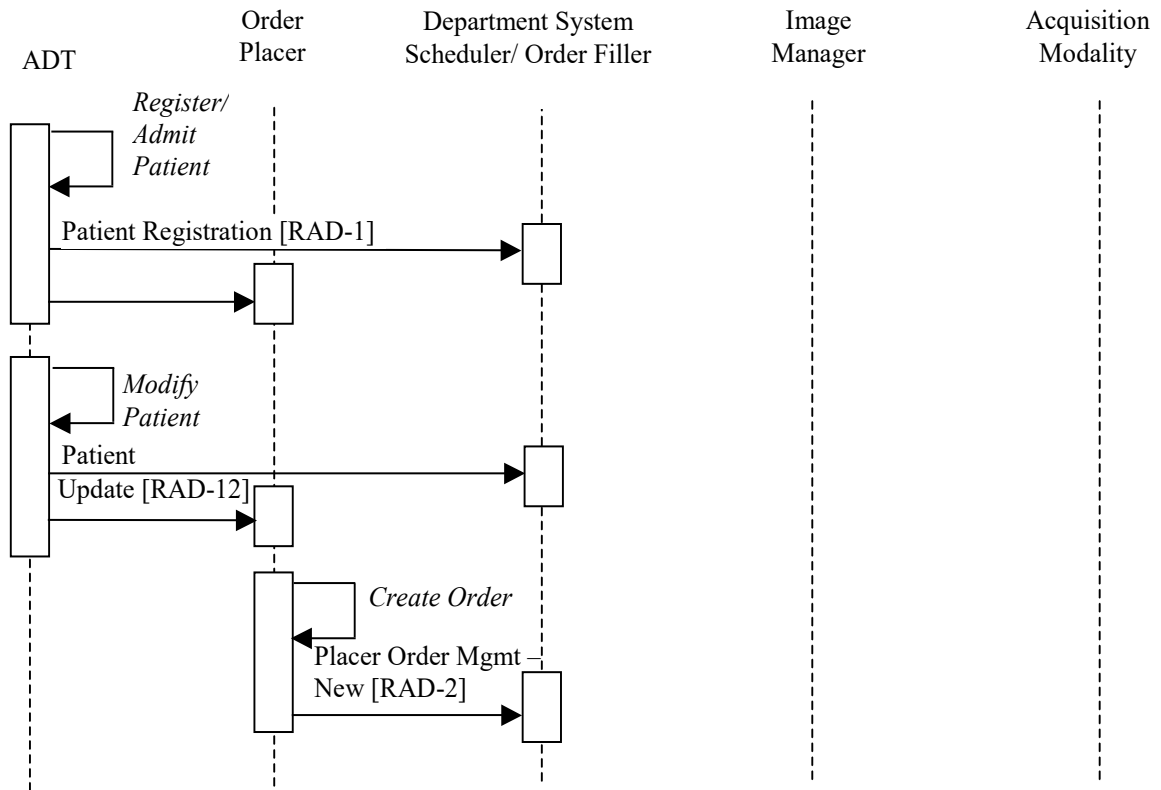
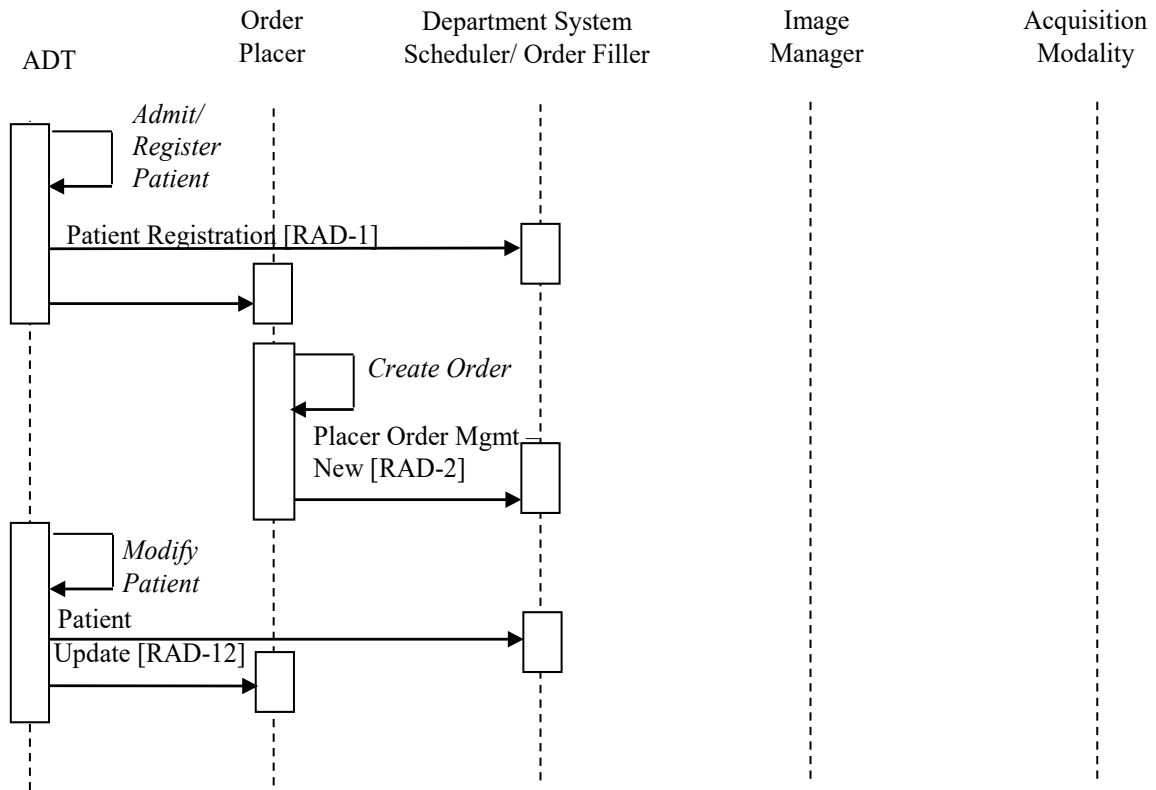

Figure 3.3.2.1-1: Patient Update before Order Entry



1550

Figure 3.3.2.1-2: Patient Update after Order Entry

The *Modify Patient* process includes changing inpatient demographics, merging two patient records and moving the information from one patient record to another.

3.3.2.2 Patient Update after Procedure Scheduling

1555 If patient information is changed after procedure(s) are scheduled by the Order Filler, the Patient Update transactions are altered as follows:

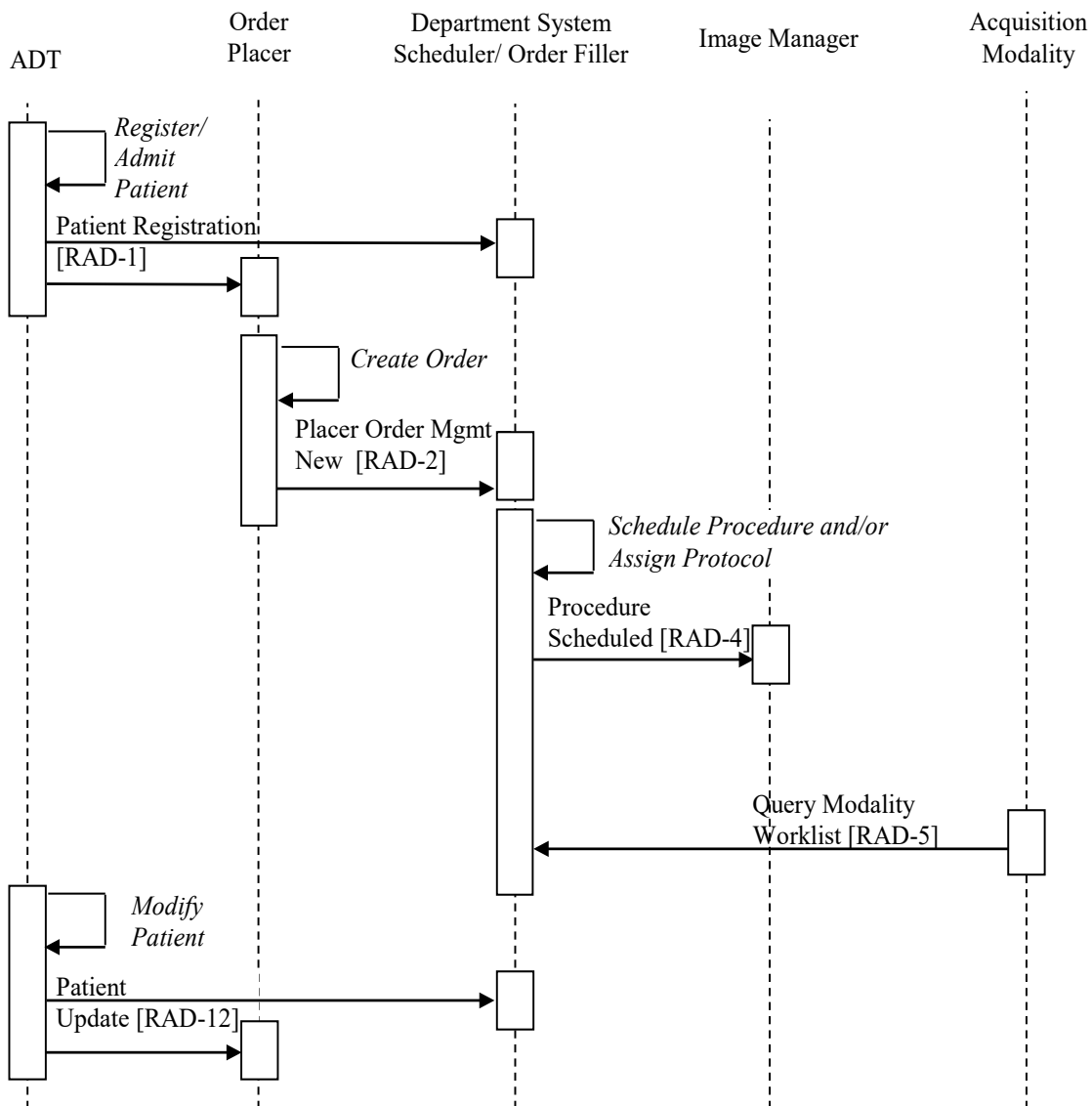

Figure 3.3.2.2-1: Patient Update after Procedure Scheduling

Note that in the Patient Information Reconciliation Profile (PIR), the Image Manager will also be notified and will have additional responsibility when Patient updates occur.

1560 **3.3.3 Order Change Flow**

3.3.3.1 Order Change Flow, HL7 v2.3.1

1565 This case covers the situation when the Order Placer or the Department System Scheduler/Order Filler has to change order information or cancel/discontinue an order. When an order information change is necessary, for HL7 v2.3.1, the Radiology Technical Framework requires the initiating actor to cancel the order and generate the new one using the new information. Figures 3.3.3.1-1 and 3.3.3.1-2 depict examples of order cancellation/re-ordering flow initiated by the Order Placer

and the Department System Scheduler/Order Filler respectively. Note that one should consider these transactions as being performed between the process flow fragments depicted in the Figures 3.3.1-1 and 3.3.1-2 to ensure synchronization of information between interested actors.

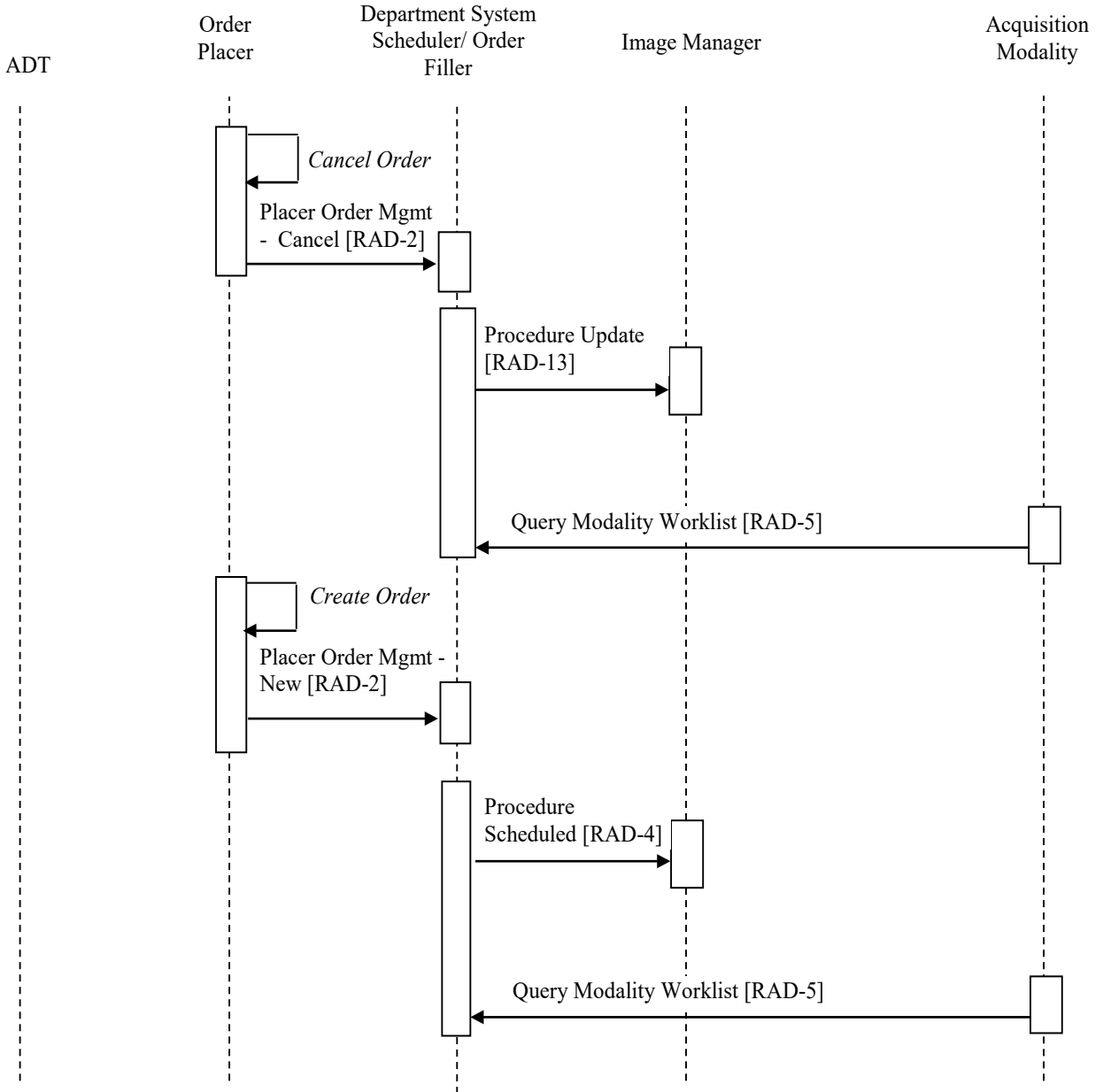

1570

Figure 3.3.3.1-1: Order Replacement by the Order Placer

Department System Scheduler/Order Filler may cancel an order received from the Order Placer and place the new order as a replacement, as shown in the Figure 3.3.3.1-2.

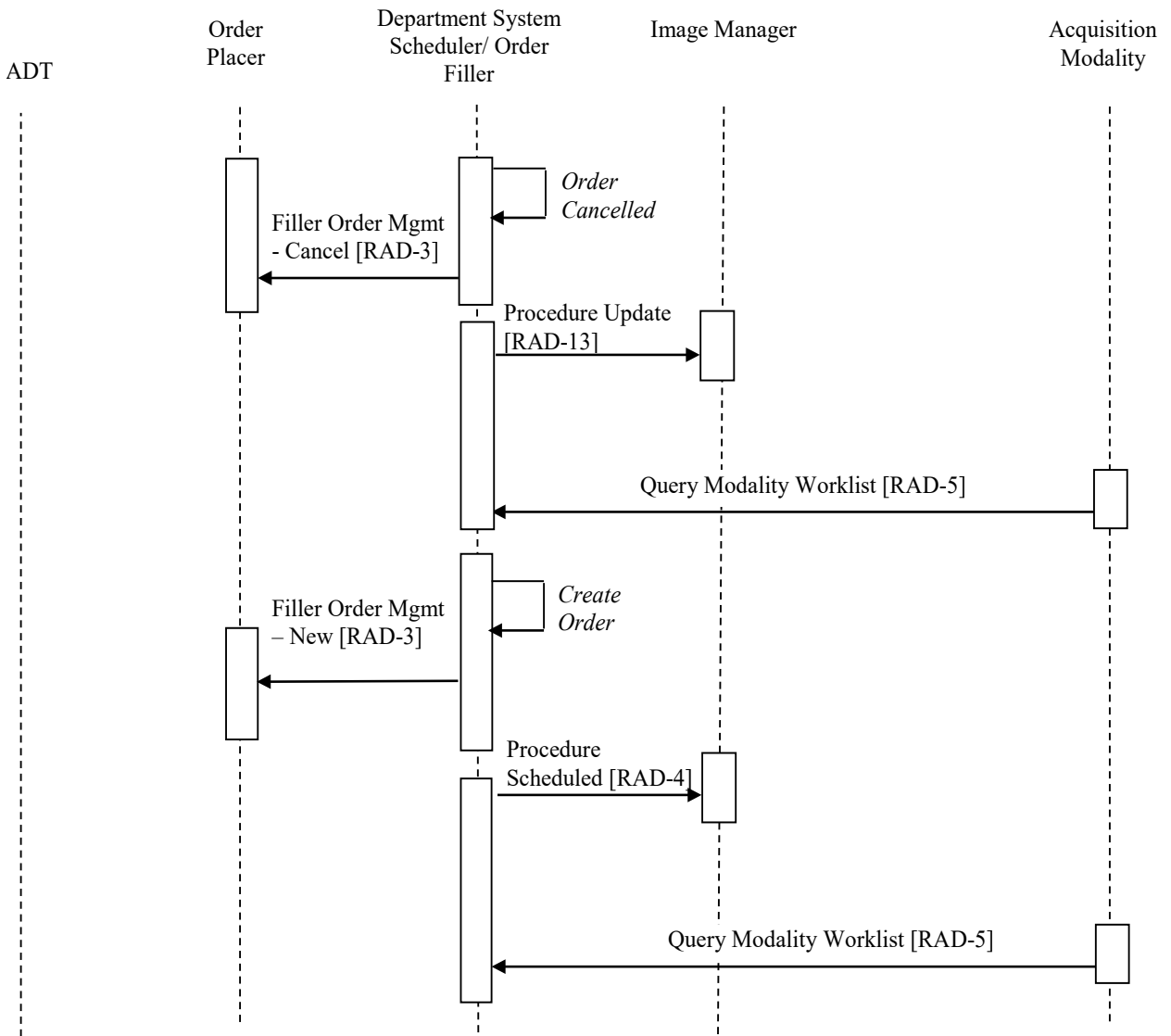

1575

Figure 3.3.3.1-2: Order Replacement by the Department System Scheduler/Order Filler

The Department System Scheduler/Order Filler may also generate a new order on its own as a means of handling the unidentified patient case discussed in Section 4.2. The process flow in such a situation corresponds to the ordering sequence in Figure 3.3.3.1-2, without the preceding Order Cancel transaction.

1580

Note: The Radiology Technical Framework does not support notification of the modality of the order discontinuation after the Modality Procedure Step In Progress message has been generated by the Acquisition Modality, i.e., the current procedure step will be completed even though the order could be discontinued.

1585 **3.3.3.2 Change Order Flow, HL7 v2.5.1 Option**

1590 This case covers the situation when the Order Placer or the Department System Scheduler/Order Filler has to change order information for systems implementing HL7 v2.5.1. When an order information change is necessary, the Radiology Technical Framework allows for the initiating actor to change the order in a single message with the new information. Figures 3.3.3.2-1 and 3.3.3.2-2 depict examples of order change flow initiated by the Order Placer and the Department System Scheduler/Order Filler respectively. Note that one should consider these transactions as being performed between the process flow fragments depicted in the Figures 3.3.1-1 and 3.3.1-2 to ensure synchronization of information between interested actors.

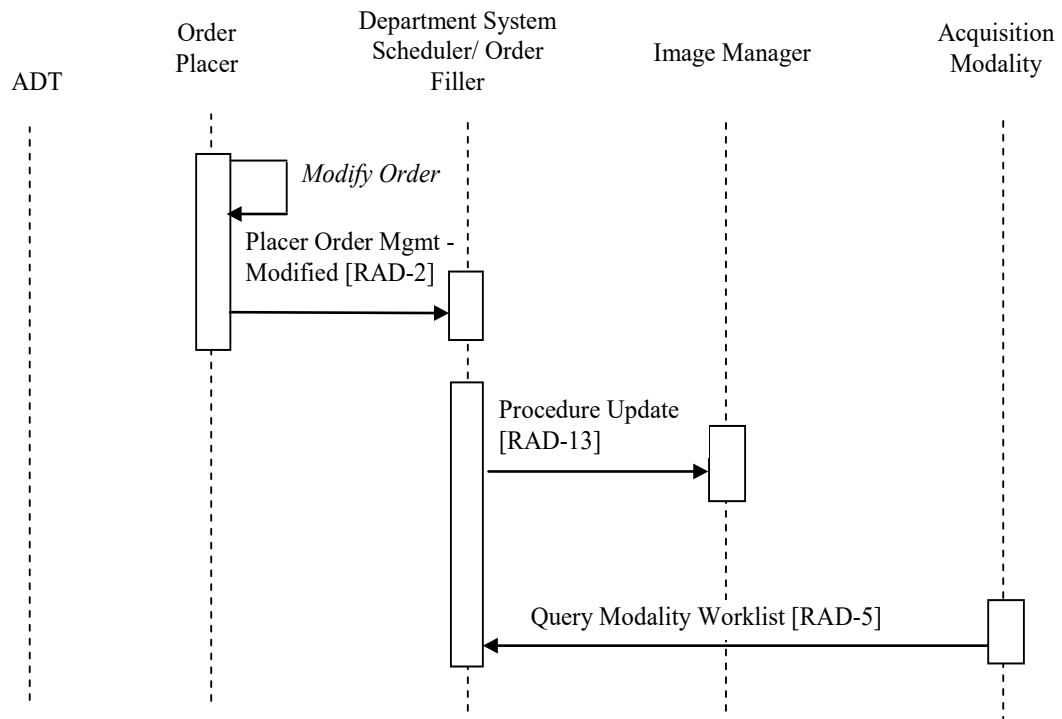

1595

Figure 3.3.3.2-1: Order Modified by the Order Placer

Department System Scheduler/Order Filler may modify an order originally received from the Order Placer, as shown in the Figure 3.3.3.2-2.

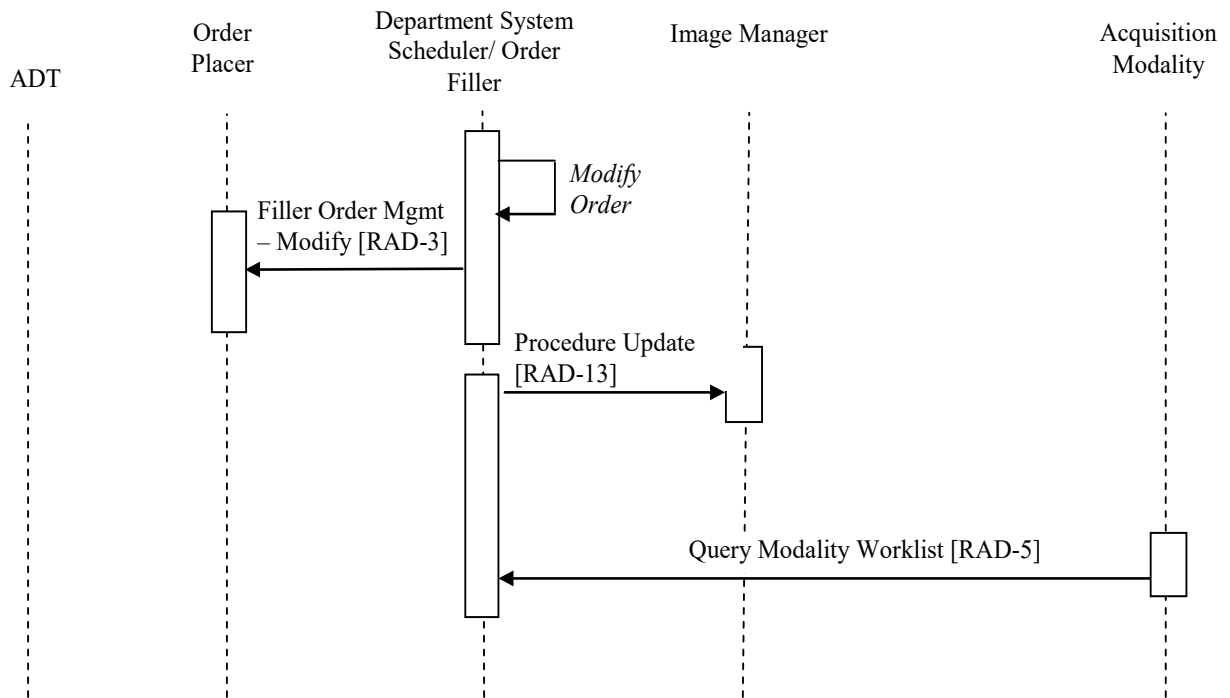

1600

Figure 3.3.3.2-2: Order Modified by the Department System Scheduler/Order Filler

The Order Placer may not change an order that has already been started, i.e., one for which Order Filler has transmitted an “In-Progress” status. However, if the Order Filler receives the change order message after it has sent the Status Update message (for example, in a case of a race condition between two messages), Order Filler will accept the change order and perform the Procedure Update [RAD-13] transaction to notify Image Manager.

1605

The Order Filler may not change a scheduled procedure step that has already been started, i.e., one for which the Acquisition Modality has transmitted an “In-Progress” status. The Radiology Technical Framework does not support notification to the modality of the Scheduled Procedure Step discontinuation or change after the Modality Procedure Step In Progress message has been generated by the Acquisition Modality, i.e., the current procedure step will be completed even though the order could be changed or discontinued.

1610

3.3.4 Exception Management Workflow

This case addresses the need to manage errors at the modality. The types of exceptions covered by this case are as follows:

1615

- Selection of the incorrect Scheduled Procedure Step from the Modality Worklist.
- The need to handle the consequences of having performed a procedure step other than the scheduled one.

1620 Some of these exception cases are addressed using required functionality for IHE actors in the Scheduled Workflow Profile and are described first in this section. Other exception cases are listed separately in this section and this Exception Management Workflow is supported by the PPS EXCEPTION MANAGEMENT Option or other options in the Scheduled Workflow Integration Profile. The following numbered items list exception cases that shall be supported by the actors listed in each item.

1625 In the course of the scheduled workflow, such exceptions may occur at different times:

1. Before the Modality Procedure Step in Progress transaction is issued, the Operator/Radiologist changes the order on the Department System Scheduler which then provides the Modality Worklist as defined by the Scheduled Workflow Integration Profile (see the Order Change flow described in Section 3.3.3). This will ensure that the most recent Worklist Information is used by the Modality. This case does not require the PPS EXCEPTION MANAGEMENT OPTION. The Acquisition Modality shall be able to process new worklist information that results from this order change; when or how the modality re-queries the Department System Scheduler is not specified by this framework.
- 1635 2. After the Modality Procedure Step in Progress transaction has been issued, but before the Modality Procedure Step Completed transaction is issued, the Operator/Radiologist may discontinue the PPS. In this case any images that may have been acquired are part of the discontinued PPS and they shall be Storage Committed. This case is supported by Abandoned case (see RAD TF-2: 4.6.4.1.2.3.5) of the Scheduled Workflow Integration Profile. See the end of this section for discussion of this case and PPS EXCEPTION MANAGEMENT Option.
- 1640 3. After the Modality Procedure Step Completed transaction has been issued, the Operator/Radiologist may notice or become aware that an incorrect worklist entry selection was made. Whether this occurs before the Requested Procedure is read or afterwards, the modality is not responsible for performing the necessary corrections. Rather the Image Manager and the Department Scheduler Actors must make such corrections (see RAD TF-2: 1645 4.7.4.1.3.1). The Image Manager and the Order Filler may also offer a correction capability to recover the erroneous instances. IHE does not provide a mechanism to propagate automatically this correction between the Image Manager/Image Archive and the Department System Scheduler/Order Filler.

1650 These next cases are optional for Acquisition Modalities and deal with using a different protocol at the modality as was scheduled by the Department System Scheduler/ Order Filler.

1. **After** the Modality Procedure Step in Progress transaction has been issued, but before the Modality Procedure Step Completed transaction is issued, the Operator/Radiologist may decide to modify the “in progress” Performed Procedure Step from what was intended by the Requested Procedure and Scheduled Procedure Step selected. In the Scheduled Workflow Integration Profile, the Acquisition Modality Actor notifies the PPS Manager (and in turn the Image Manager and the Department System Scheduler) by returning a Procedure Code Sequence of zero length. In addition, if the ASSISTED ACQUISITION PROTOCOL SETTING Option is supported by the Acquisition Modality, it can indicate this change by

- 1660 returning a Performed Protocol Code Sequence different from the Scheduled Protocol Code Sequence (see Figure 3.3.4-4 below).
- 1665 2. **Before** the Modality Procedure Step in Progress transaction is issued, the Operator/Radiologist decides to proceed without changing the order on the Department System Scheduler/Order Filler by performing one or more Procedure Steps different than scheduled by the Modality Worklist entry as defined by the Scheduled Workflow Integration Profile. Its handling at the Acquisition Modality may be facilitated by the ASSISTED ACQUISITION PROTOCOL SETTING Option.

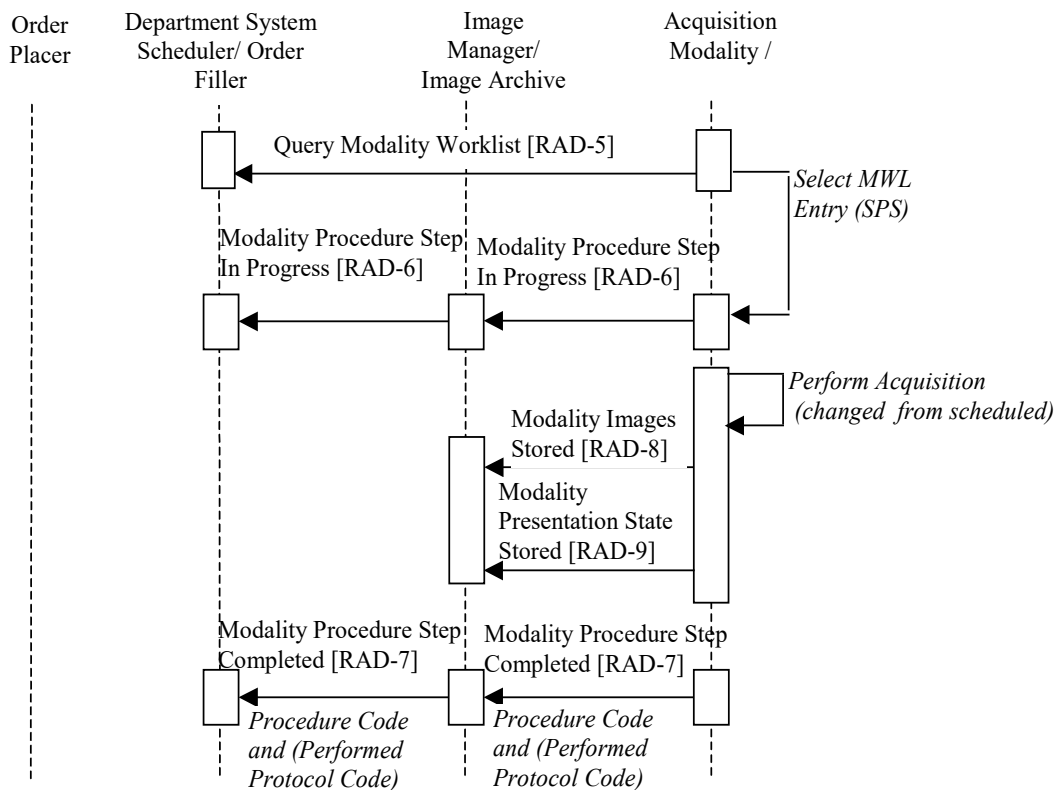

1670 **Figure 3.3.4-1: Exception Management Workflow (Changed from Scheduled on Modality)**

The last case in this section describes how the PPS EXCEPTION MANAGEMENT Option may be utilized in the Scheduled Workflow Integration Profile. This feature is optional for the Acquisition Modality, Department System Scheduler and Image Manager Actors.

- 1675 1. After the Modality Procedure Step In Progress transaction has been issued, the Operator/Radiologist may realize that the wrong SPS has been selected (incorrect patient or incorrect Requested Procedure/Order for the same patient). In this case some of the acquired images or other evidence objects may already have been stored to the Image Manager/Image Archive (with or without storage commitment confirmed). With the PPS EXCEPTION MANAGEMENT Option of the Scheduled Workflow Integration Profile, the Acquisition

- 1680 Modality Actor notifies the PPS Manager (and in turn the Image Manager and the Department System Scheduler/Order Filler) of the error so that these systems take appropriate action (See RAD TF-2: 4.7.4.1.3.1 and Figure 3.3.4-2 below).
- IHE does not define how the modality may dispose of and/or correct the images or other evidence objects. Each implementation shall decide if it is useful to support the storage of the corrected images or other evidence objects, when clinically meaningful. However if they do,
- 1685 new *Modality Procedure Step in Progress/Completed* and Storage Commitment transactions shall be used.
- In this case, the PPS EXCEPTION MANAGEMENT Option of the Scheduled Workflow Integration Profile provides further functionality. The Modality Actor notifies the PPS
- 1690 Manager (and in turn the Image Manager and the Department System Scheduler) of the reason for the discontinuation so that these systems may take the appropriate actions (see Figure 3.3.4-3 below).

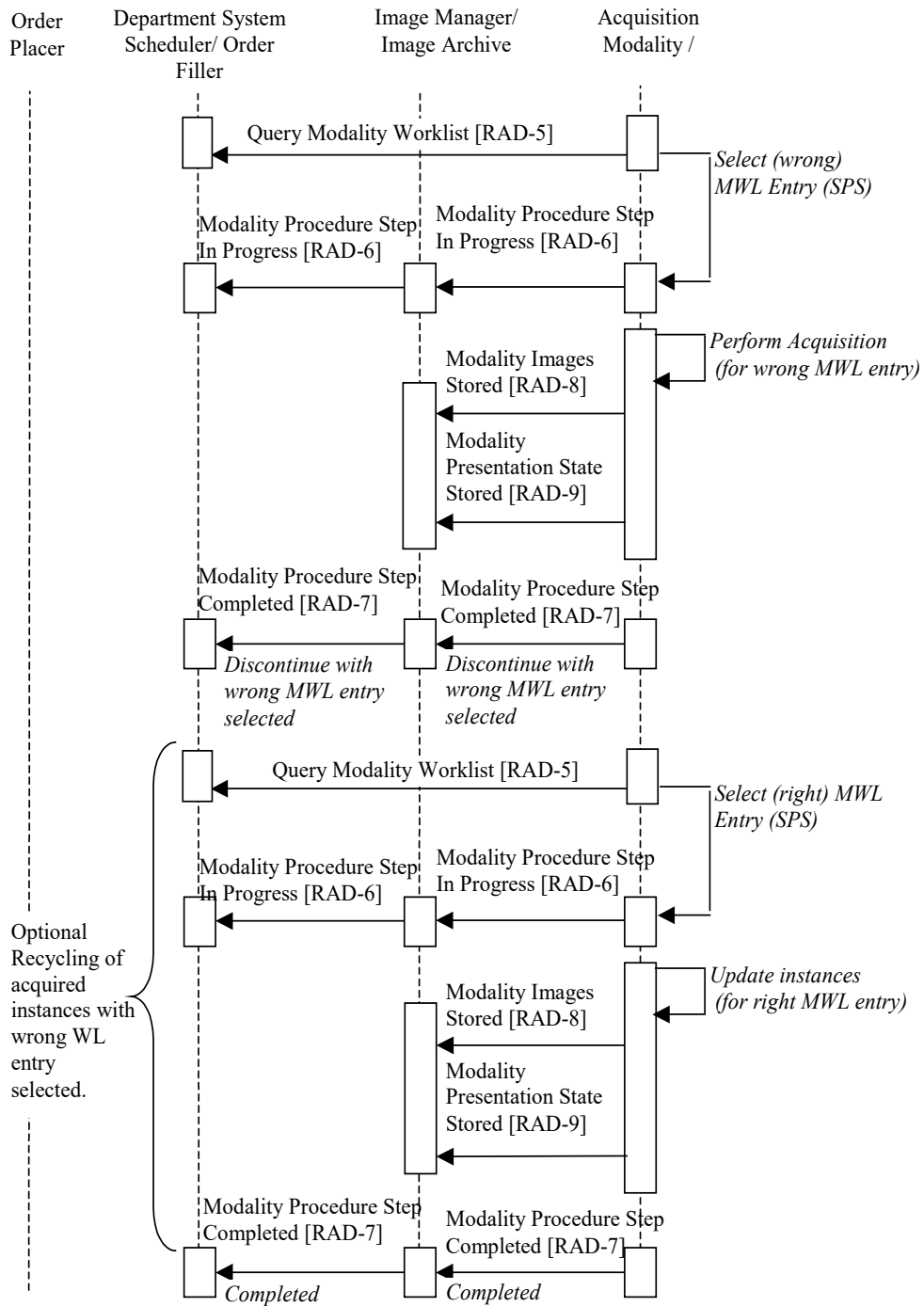

1695

Figure 3.3.4-2: Exception Management Workflow (Wrong Worklist Entry Selected)

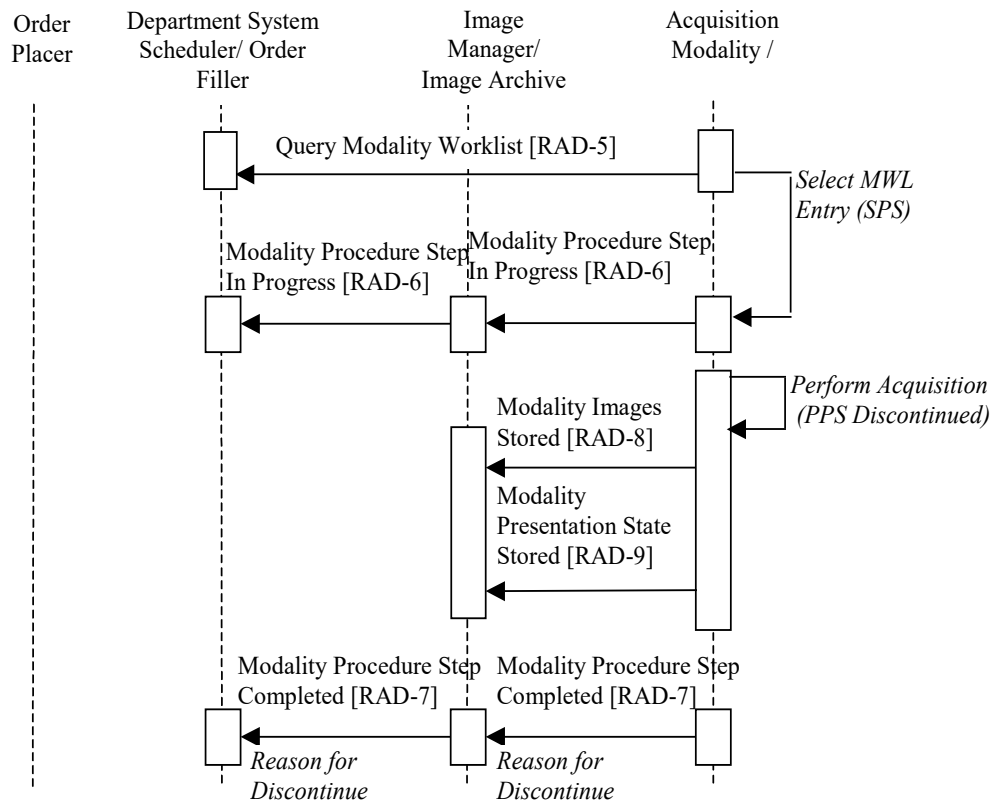

Figure 3.3.4-3: Exception Management Workflow (Discontinued with a Reason)

3.3.5 Implicit Post-Processing

1700 This case addresses image post-processing tasks performed as an implicit part of the Scheduled Workflow.

In general, post-processing tasks scheduled and managed explicitly using post processing worklists are addressed by the Post-Processing Workflow Integration Profile (see Section 12 for further details on that profile). However, at some sites, post-processing tasks performed on the acquisition system or adjacent workstations are implied by the information in the acquisition worklist. In such cases, the post-processing is managed by the technician simply carrying out the steps following acquisition.

1710 Technicians may be instructed that certain post-processing should always be performed for certain acquisitions, or alternatively, different protocol codes may be provided in the acquisition worklist to indicate intended post-processing. In either case, no worklist is used on the post-processing Evidence Creator.

In the case of this “implicit post-processing workflow”, the Evidence Creator may obtain source images and other evidence objects necessary for post-processing by receiving them from the Acquisition Modality Actor (either pulled or pushed via some non-IHE defined mechanism) or by being grouped with an Image Display Actor (giving the system query/retrieve capabilities).

1715 Based on the information contained in the images, the Evidence Creator can send status messages and store its results according to the IHE transactions as shown in the following use cases.

The following sequence of steps describes the typical process flow when the Evidence Creator receives the images from an Acquisition Modality via some non-IHE means.

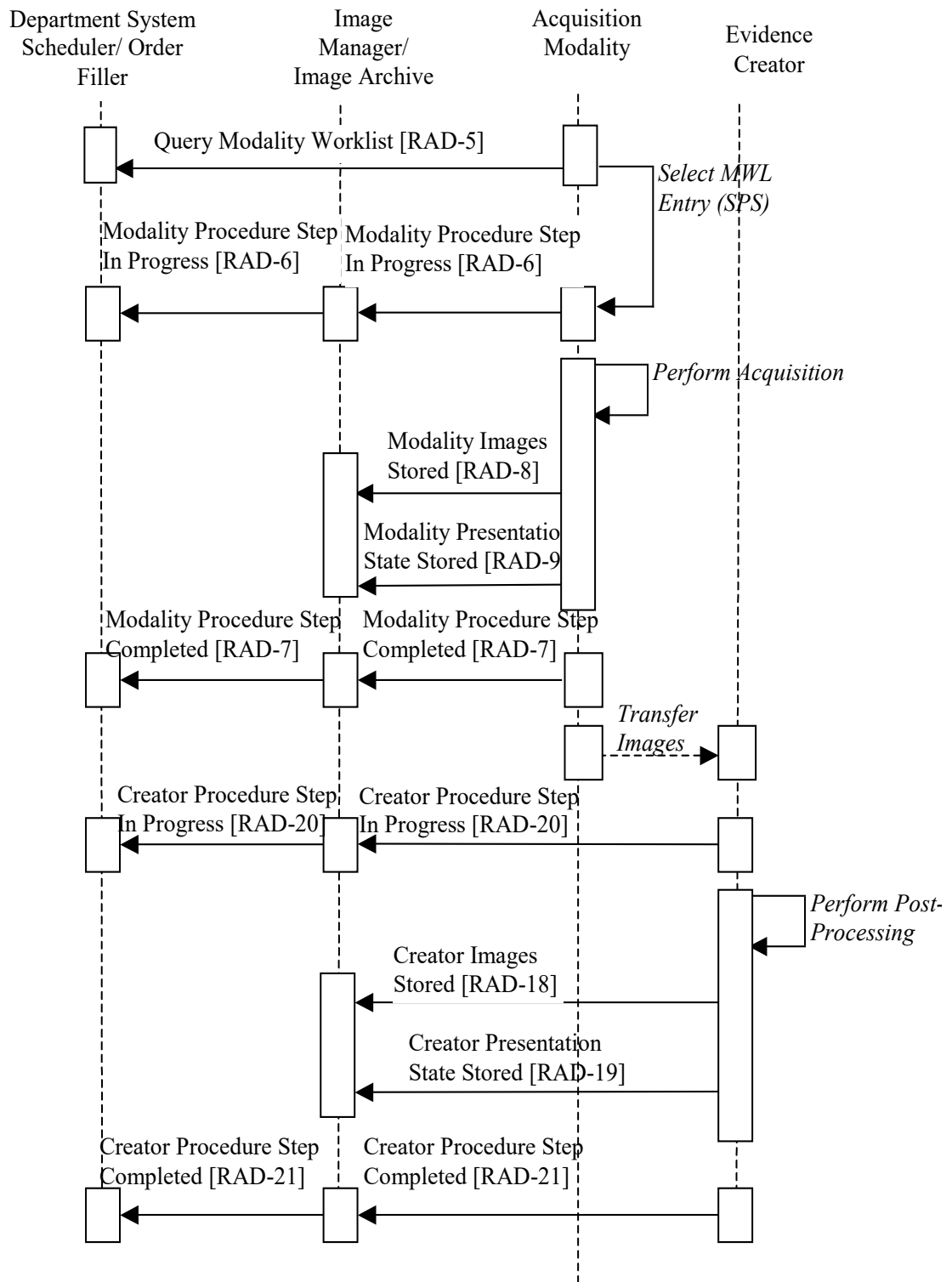

Figure 3.3.5-1: Post-processing in Scheduled Workflow

1720

Note: The Modality Presentation State Stored [RAD-9] and Creator Presentation State Stored [RAD-19] transactions are not a part of this profile; they are displayed for illustration purposes only.

1725 The following should be noted in relation to the Post-Processing process flow in Scheduled Workflow as described above:

- The images for post-processing are transferred from the Acquisition Modality to the Evidence Creator by means that are out of scope of the Radiology Technical Framework.

1730 • *Perform Post-Processing*: The Evidence Creator uses the source images and/or other evidence objects it receives from the Acquisition Modality to perform post-processing tasks and generate new set(s) of images and/or other evidence documents. It uses information from the source images to populate the newly created objects and the Creator Performed Procedure Step Messages.

1735 The following sequence of steps describes the typical process flow when Evidence Creator is grouped with Image Display.

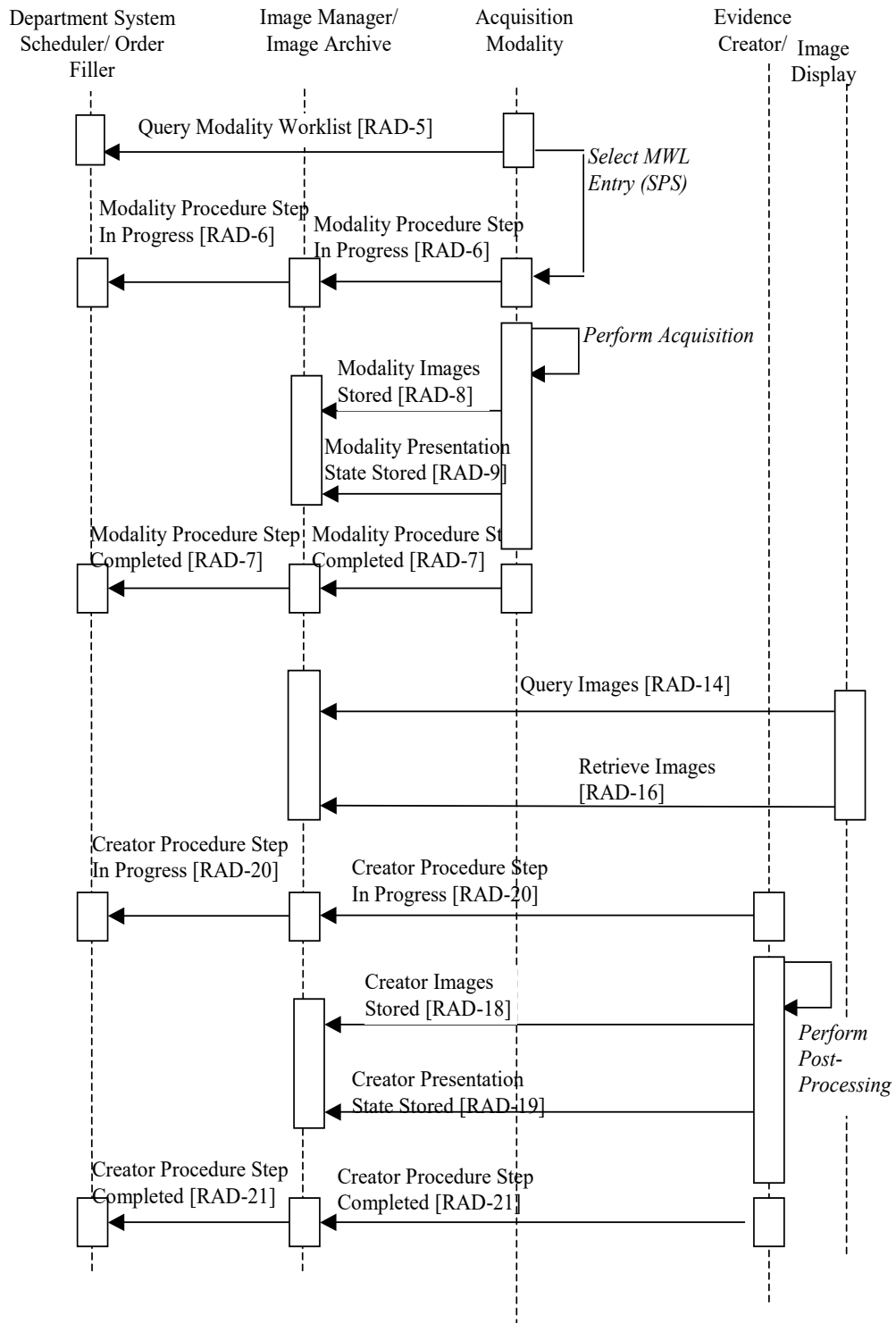

Figure 3.3.5-2: Post-processing in Scheduled Workflow (performed on Evidence Creator)

Note: The Modality Presentation State Stored [RAD-9] and Creator Presentation State Stored [RAD-19] transactions are not a part of this profile; they are displayed for illustration purposes only.

1740 The following should be noted in relation to the Post-Processing process flow on the independent workstation:

- The Evidence Creator is grouped with the Image Display and the images for post-processing are retrieved from the Image Archive where the Acquisition Modality has transferred them.

1745 • *Perform Post-Processing*: The Evidence Creator uses the source images and/or other evidence objects it receives from the Image Archive to perform post-processing tasks and generate new set(s) of images and/or other evidence documents. It uses information from the source images to populate the newly created objects and the Creator Performed Procedure Step Messages.

1750 **3.3.6 Departmental Appointment Booking**

This case addresses the use of the Departmental Appointment Notification Option by the Order Placer and Order Filler Actors.

1755 Order Fillers that support this option shall have ability to be configured so that the Appointment Notification transaction is not sent when connected to an Order Placer that does not support the Departmental Appointment Notification Option.

1760 In the IHE Scheduled Workflow Integration Profile, the scheduling needed to perform an Order is managed by the Departmental System Scheduler/Order Filler. The Order Placer may request along with an Order a preferred date and time for this Order, but it is the Order Filler that sets, updates and possibly cancels the appointment(s) for examinations. When a new Order is placed by the Order Placer or the Order Filler, an Appointment Notification (New Bookings) is sent to the Order Placer. This Appointment Notification (New Bookings) may include several appointments bookings in case some of the Scheduled Procedure Steps require separate appointments. Equally, one or more Scheduled Procedure Steps may be scheduled during the same appointment booking.

1765 If any changes to some of these appointments are made by the Order Filler, it issues an Appointment Notification (Reschedule Bookings) to inform the Order Placer of the change. If that appointment is cancelled by the Order Filler, it issues an Appointment Notification (Cancel Bookings) to the Order Placer.

1770 This Departmental Appointment Notification Option allows the Order Placer to remain aware of any scheduling changes that may be made by the Order Filler, but not to request an appointment change. For such a change, it may be necessary to use means not defined in this Integration Profile (e.g., a phone call to the person entering orders on the Order Filler) that an appointment booking has to be changed.

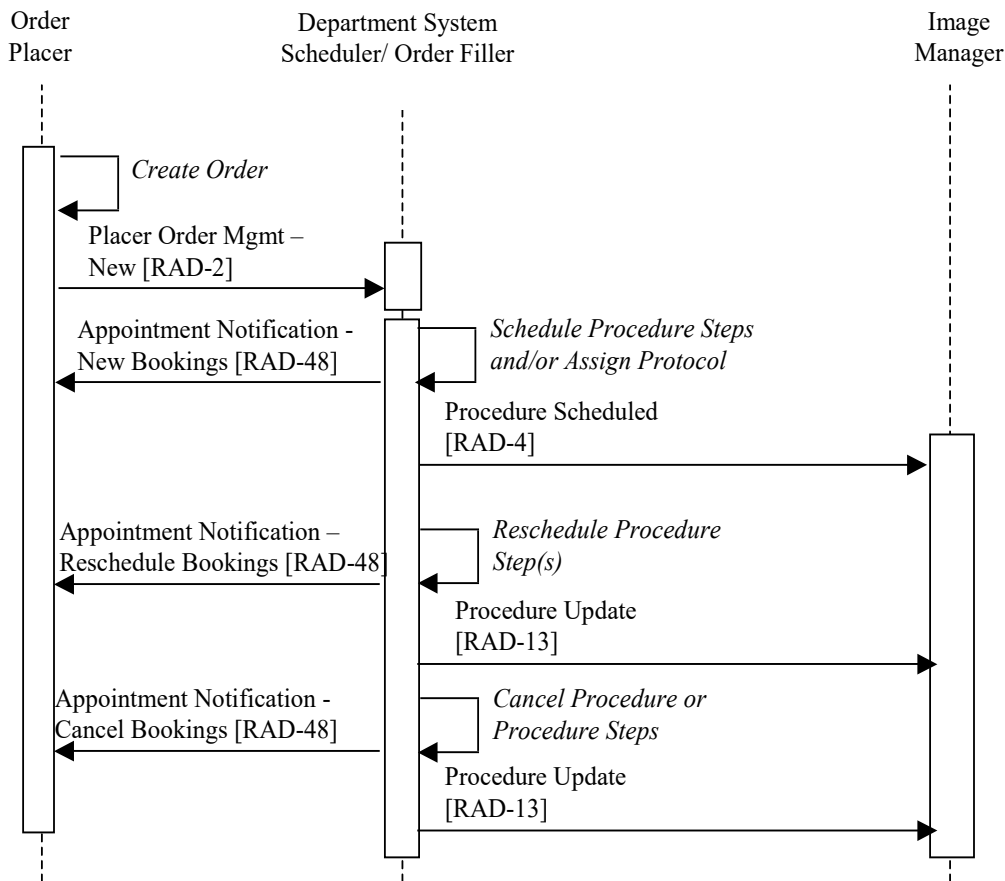

1775

Figure 3.3.6-1: Departmental Appointment Bookings Process Flow

3.4 Data Model for Scheduled Workflow

This section defines the integrated data model adopted by the Radiology Technical Framework for the HL7 messages and the DICOM Information Object Definitions (IODs). The Entity Relationship (ER) diagram represents the integration of proper subsets of HL7 v2.3.1 and the DICOM Model of the Real World with minor extensions as noted in Section 3.4.1 and described in Appendix B.

1780

3.4.1 Model of the Real World

Figure 3.4-1 depicts the model of the real world within scope of the Scheduled Workflow Profile. This model provides an overview of the high-level integration of the DICOM and HL7 models. This integrated model differs from the DICOM Model of the Real World (refer to DICOM PS3.3) in the following respects:

1785

- The Service Episode, Procedure Plan and Procedure Type entities have been excluded and are outside the scope of the Radiology Technical Framework

- 1790 • The relationship between the Visit and Imaging Service Request has been excluded and is outside the scope of the Radiology Technical Framework.
- The HL7 Placer Order and Filler Order entities have been inserted into the DICOM hierarchy between the Patient entity and Imaging Service Request entity. IHE requires that a single Placer Order shall correspond to one and only one Filler Order.
- 1795 • The DICOM Imaging Service Request Entity is equated with the HL7 Filler Order entity. In this relationship, IHE provides clarification of the use of the Accession Number - DICOM attribute (0008,0050); see Appendix A for further discussion.

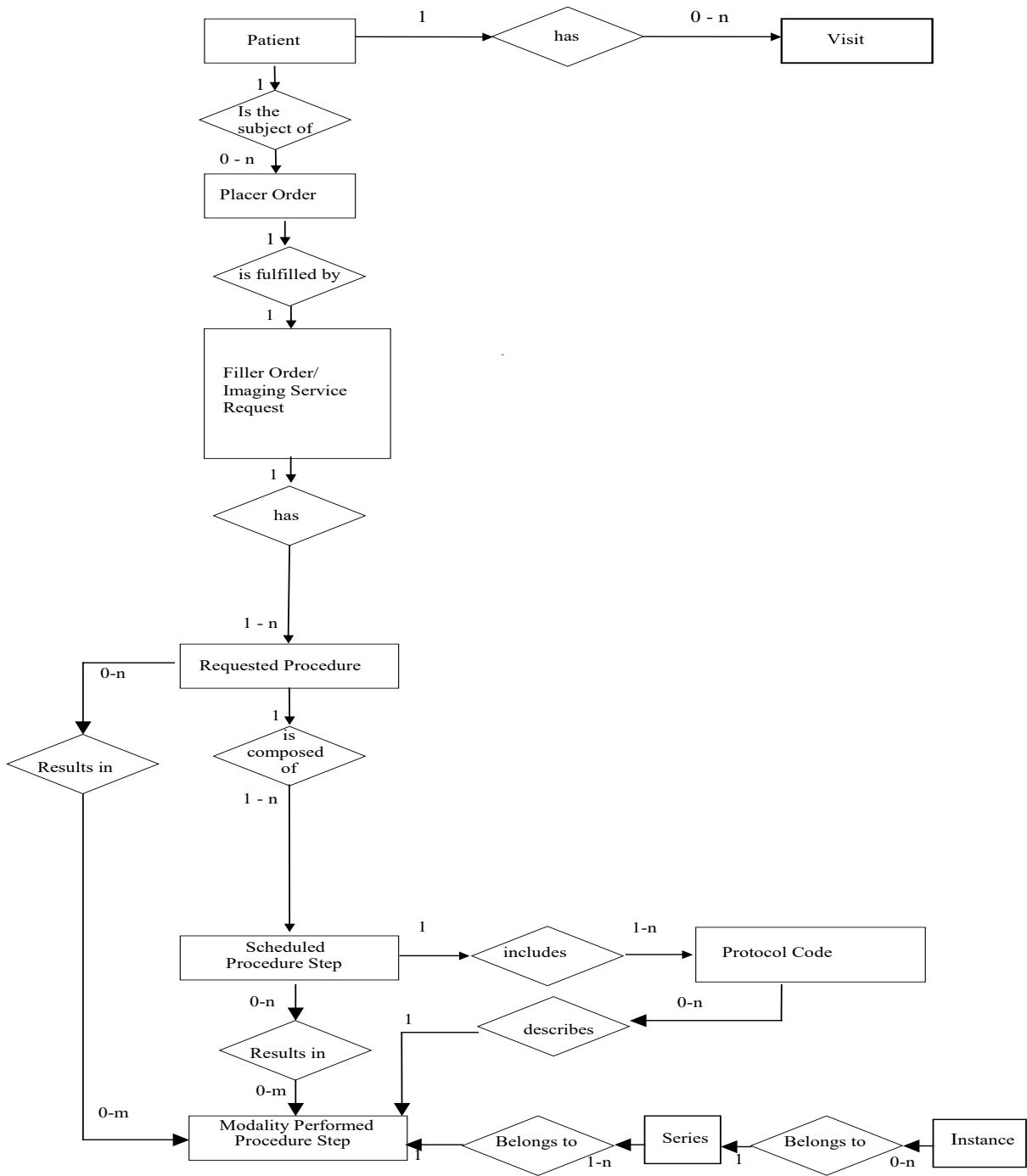

1800

Figure 3.4-1: Real World Model for Scheduled Workflow

3.4.2 Scheduled Workflow Concepts in Practice

The IHE “Real World” model for Scheduled Workflow described above offers three major levels of control that can be used to customize a broad range of specific workflow situations:

- **Order:** A request for an Imaging Service
- 1805 • **Requested Procedure:** Unit of work resulting in one report with associated codified, billable acts.
- **Scheduled and Performed Procedure Step:** the smallest unit of work in the workflow that is scheduled (work to do) and/or performed (work done).

1810 The Order Filler/Department System Scheduler uses the Universal Service ID in each order that it receives to determine what specific Requested Procedures are needed, and for each Requested Procedure the Procedure Steps that need to be scheduled.

1815 A departmental Procedure Plan may be used in the Order Filler Actor to predefine for each one of the types of Orders that may be requested from the imaging department (generally defined in the Order Placer) the breakdown in Requested Procedure (with a specific procedure code) and for each Requested Procedure Code, the breakdown in Scheduled Procedure Steps.

The figure below defines an example of the breakdown of a “rule out pulmonary embolism” Order.

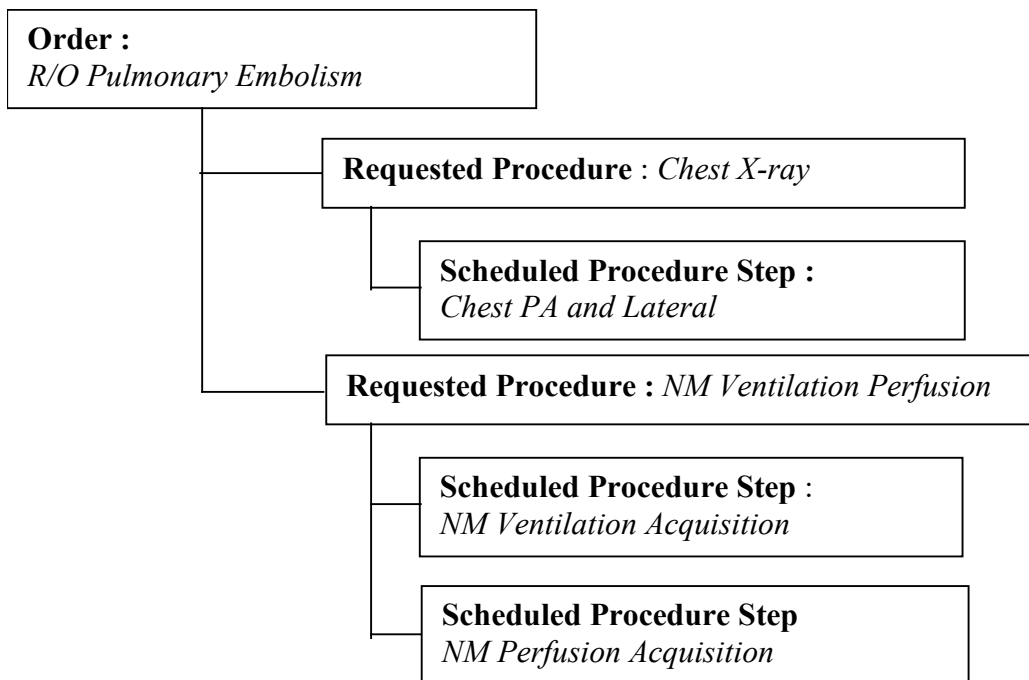

1820 In this Procedure Plan, for this specific Order, two Requested Procedures are defined. The Chest X-ray that will be read and reported by a different radiologist than the NM Ventilation-Perfusion, hence two different Requested Procedures. The NM Ventilation Perfusion Procedure has been scheduled as two different Scheduled Procedure Steps, to account for the fact that the patient will

have the two NM acquisitions performed at a different time, thus allowing for patient preparation between the two examinations. This is the way this institution has decided to handle this Order.

1825 Another Institution may choose to require the same radiologist to read both the X-ray and the NM images. In that case it would define in its Procedure plan for the same Order to have a single Requested Procedure with three Scheduled Procedure Steps.

Many Orders processed in a Radiology Department would have a simpler breakdown such as this Chest X-ray example.

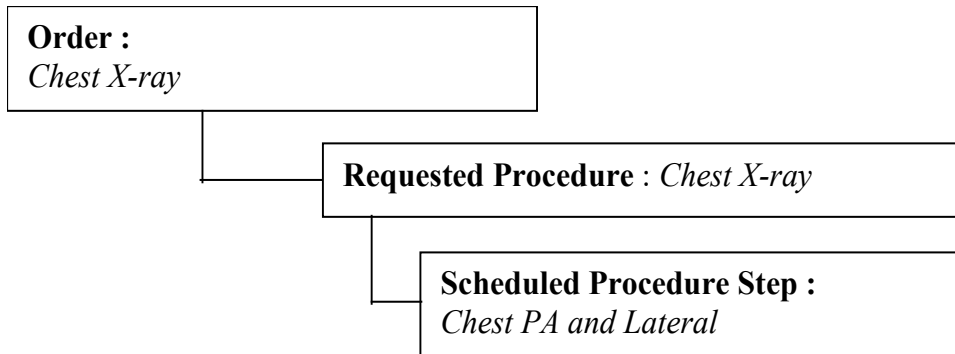

1830

It should be noted that the three level Order breakdown has been defined in the IHE Scheduled Workflow so that any type of Orders, from the simple case to the more complex cases may be handled by the same workflow concepts, thus providing a general approach that can be easily customized by each imaging department in the definition of its Procedure Plan.

1835 In the IHE Scheduled Workflow, the **Accession Number identifies the Order**. The requested Procedure ID distinguishes among Requested Procedures when an Order requires multiple Procedures. IHE sets a common meaning for these two terms to provide clinicians with a consistent and non-ambiguous access across different vendor products (RIS, PACS and Modalities).

1840 **3.4.2.1 Tracking Performed Procedure Steps**

The IHE Scheduled Workflow not only addresses the breakdown of Orders into Requested Procedures and Scheduled Steps but also allows tracking the Procedure Steps that have actually been performed. The Performed Procedure Steps may or may not correspond to the Scheduled Procedure Steps. This provides the flexibility needed to adjust on the Modality if the actual acquisition differs from what was scheduled.

1845

Using the Pulmonary Embolism example above, one may decide to follow the Order breakdown as defined in the procedure Plan.

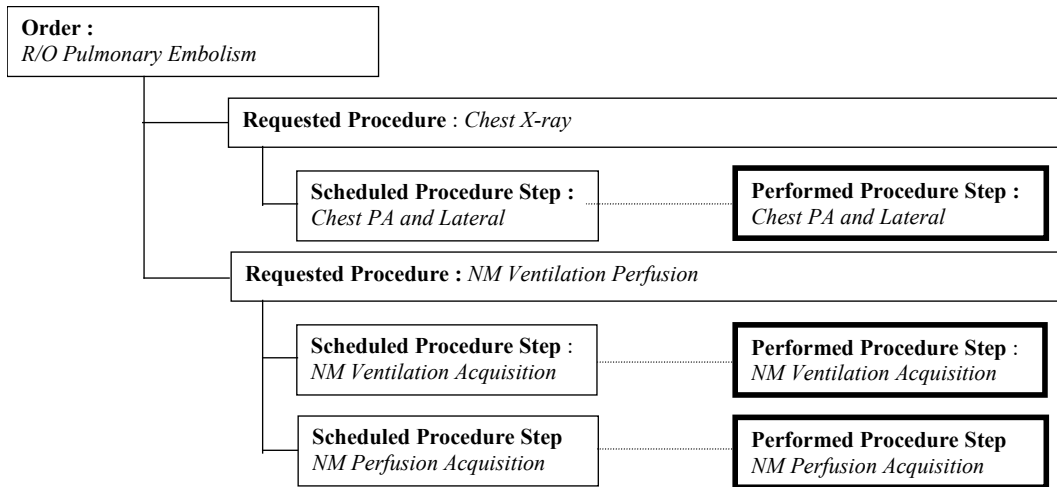

1850 The Chest X-ray Requested Procedure would contain the series of images associated with the Chest PA and Lateral Performed Procedure and the NM Ventilation Perfusion would contain both the series for the ventilation and the series of images for the perfusion. From this example one can see how the Requested Procedure forms the “folder” where the radiologists find the images to be read resulting from the Scheduled Procedures Steps.

1855 Using the Pulmonary Embolism example above, one may decide that following the Chest X-ray, it is not necessary to perform the NM Perfusion Ventilation.

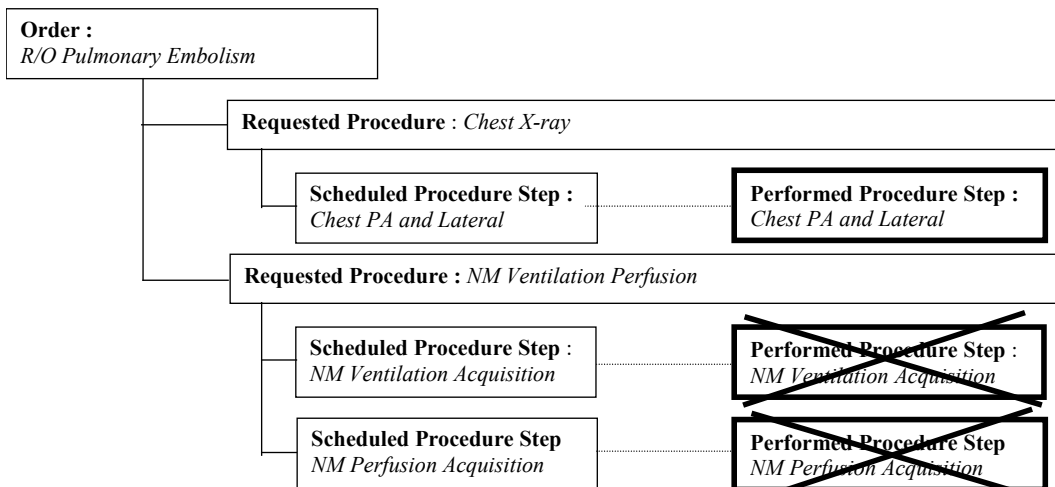

In this later case, the Nuclear Scheduled Procedure Steps will be cancelled. Only the Chest X-ray Requested Procedure will “contain” the Image corresponding to the Chest PA and lateral Chest X-ray.

1860 To illustrate further the capabilities of the IHE Scheduled Workflow Profile, let's look at a Chest/Abdomen/Pelvis Order that a radiology department chooses to break down into a Chest Requested Procedure and an Abdomen/Pelvis Requested Procedure in order to take advantage of the subspecialties of its radiologists. Some hospitals also may want to produce separate reports to align with the charging policies.

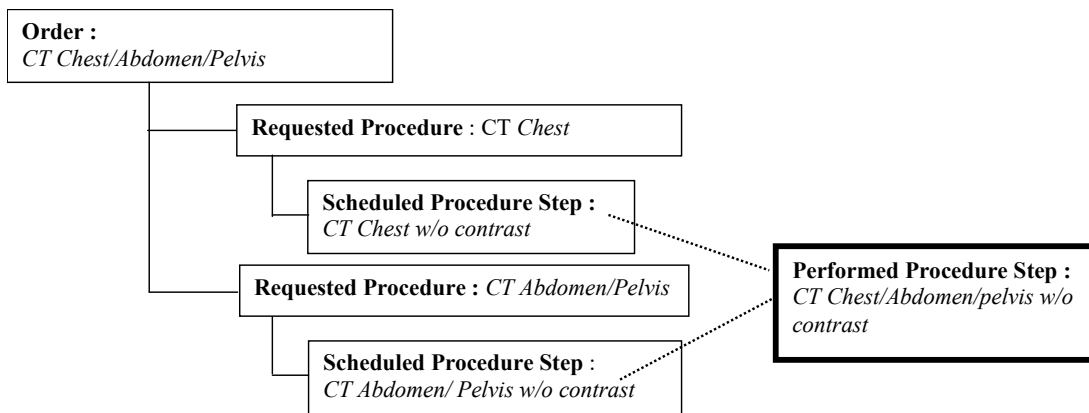

1865

In this example, a single Performed Procedure Step has been performed in response to two Scheduled Procedure Steps. IHE refers to this as a Group Case (see RAD TF-2: 4.6). At the time of reading, the same series of images produced by this Performed Procedure Step would be read once in the context of the CT Chest Requested Procedure and again in the context of the Abdomen/Pelvis Requested Procedure.

1870

3.4.2.2 Extending the Scheduled Workflow Concepts to Include Post-Processing Tasks

The workflow concepts (as described in Section 3.4.2.1 above) may be extended to include other Scheduled Procedure Steps, such as those used to describe post-processing tasks.

1875

Some of the Scheduled Procedure Steps may be Image Post-Processing related. These Scheduled Procedure Steps would result in Post-Processing Performed Procedure Steps. This is illustrated by the following example of an MR Brain with a Functional Analysis Post-Processing.

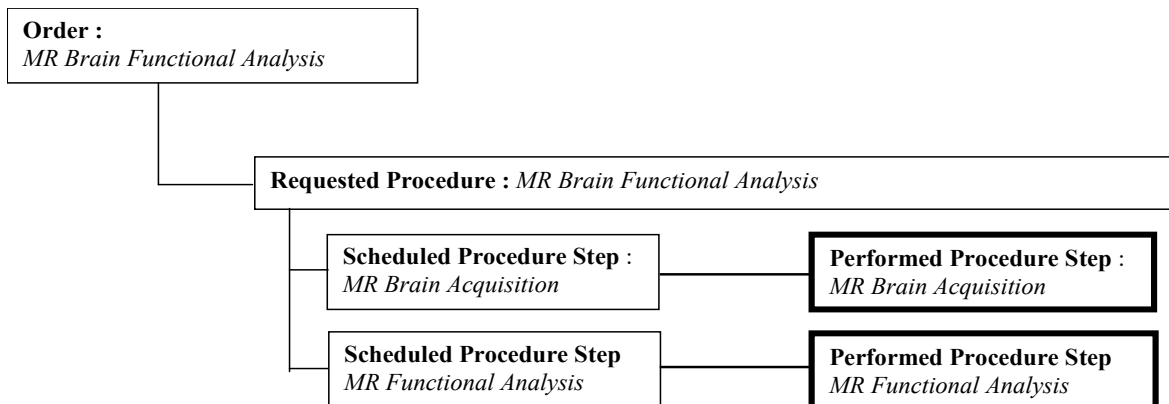

1880

In the above example, two different Scheduled Procedure Steps have been defined for the Requested Procedure. This reflects the fact that in this radiology department, the functional analysis post-processing is not performed by the MR Technologist, but by the Radiologist and therefore needs to be independently scheduled on an independent workstation. Another department may well choose to have the Technologist perform the post-processing immediately after the MR acquisition (either on the MR itself or on a co-located workstation). In that case the

1885 Requested Procedure would include a single Scheduled Procedure Step that includes both the acquisition and the post-processing task.

1890 This Section does not provide an exhaustive description of all the workflow cases supported by the IHE Scheduled Workflow Profile, nor does it describe the Workflow enabled by other IHE Integration Profiles such as the Presentation of Grouped Procedures, Post-Processing Workflow and Reporting Workflow.

3.4.3 Scheduled Workflow Information Model

1895 The Scheduled Workflow Model is represented in this section as an Entity Relationship (ER) diagram. The Scheduled Workflow Model is based on the DICOM and HL7 standards. The keys relating the entities and the unique keys of each entity are defined and the cardinality of the entities is indicated.

An example of the conventions used to specify an entity's relationships is presented in Figure 3.4-2.

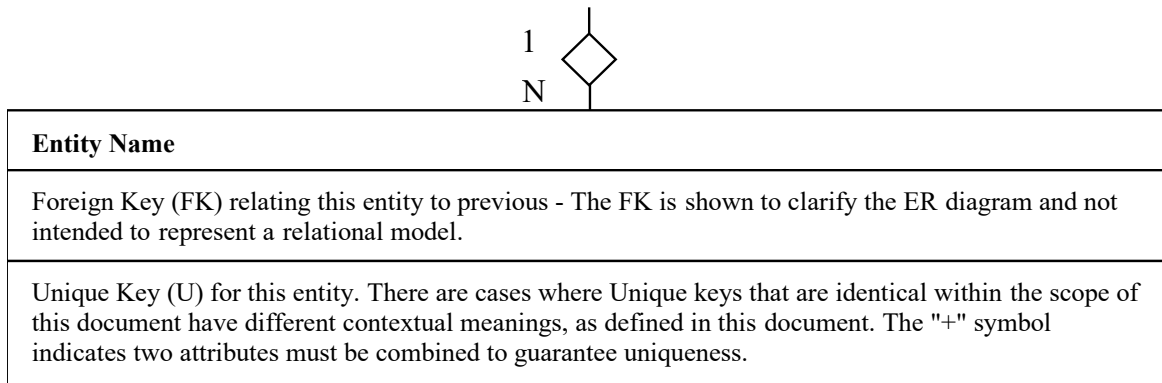
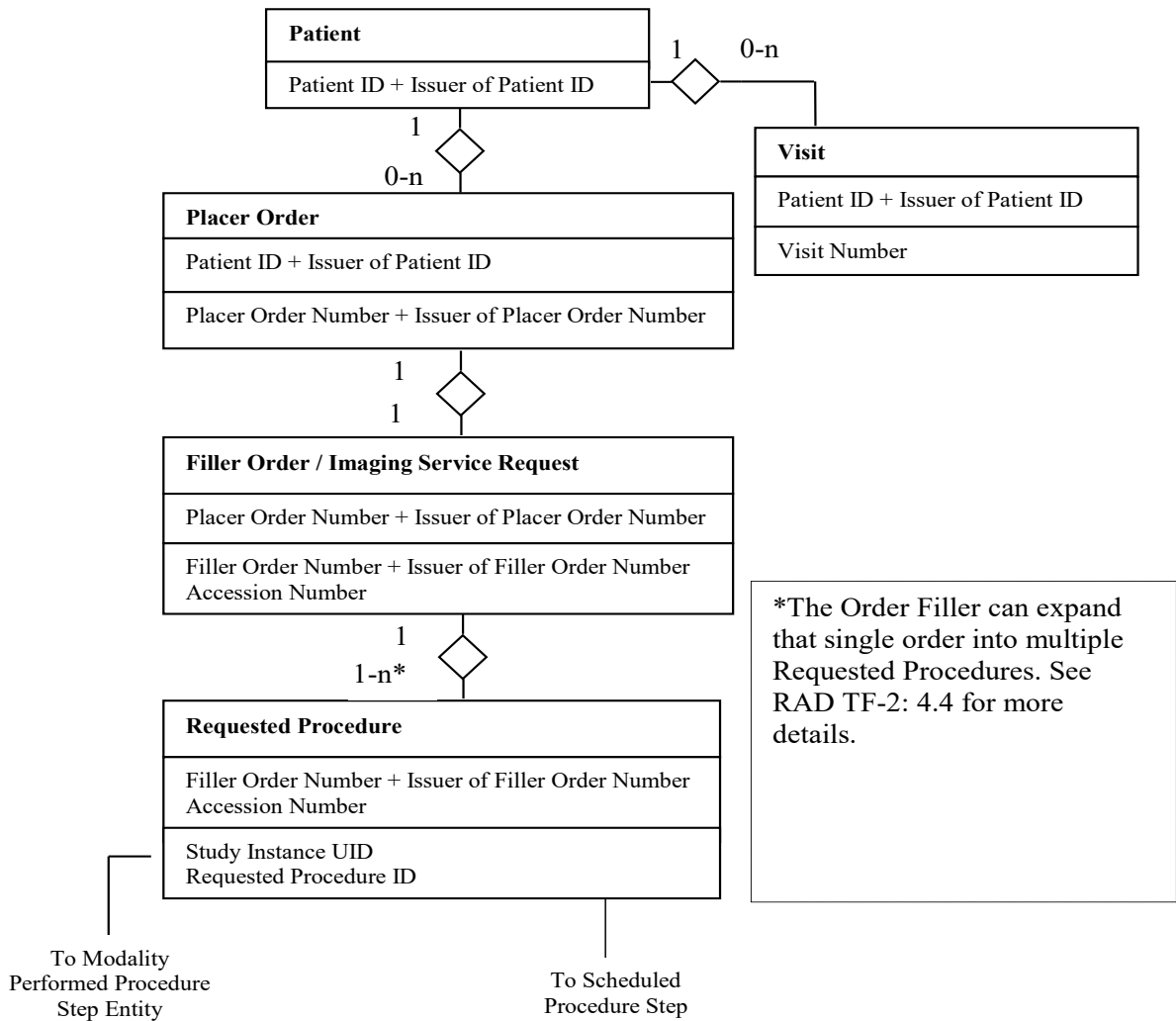

Figure 3.4-2: Example of the Entity Relationship Diagram

1900 Figures 3.4-3 and 3-4.4 present the overview of the IHE Information Model. Mappings between specific HL7 Elements and DICOM Attributes are identified in RAD TF-2: Appendix B.



1905

Figure 3.4-3: Schedule Workflow Information Model

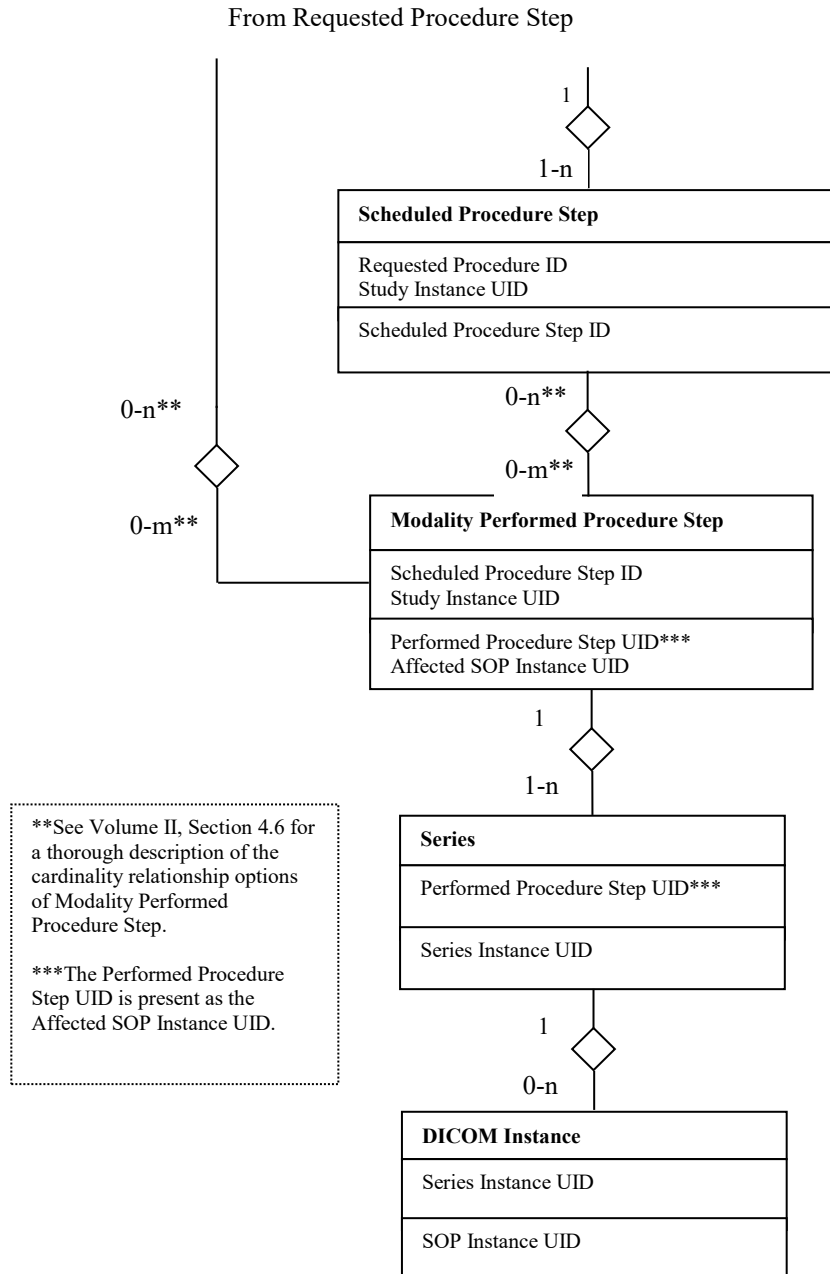

1910

Figure 3.4-4: Schedule Workflow Information Model, continued

4 Patient Information Reconciliation (PIR)

1915 The *Patient Information Reconciliation Integration Profile* extends the *Scheduled Workflow*
and the *Reporting Workflow Integration Profile* by offering the means to match images,
diagnostic reports, and other evidence objects acquired for a misidentified or unidentified patient
(for example, during a trauma case) with the patient's record. In the example of the trauma case,
1920 this integration profile allows subsequent reconciliation of the patient record with images that are
acquired (either without a prior registration or under a generic registration) before the patient's
identity can be determined. Thus, images can be acquired and interpreted immediately and later,
when the patient's official registration and order information is entered into the ADT, Order
Placer and Order Filler Systems, this information is matched with the acquired image set and
reports, greatly simplifying these exception handling situations. In addition, this Integration
Profile allows the Image Manager and Report Manager to receive patient update messages to
maintain consistency of the patient information. The Image Manager and Report Manager do not
1925 receive those transactions in the Scheduled Workflow Integration Profile.

4.1 Actors/Transactions

Figure 4.1-1 diagrams the actors involved with this profile and the transactions between actors. The shaded actors are NOT actually included in this profile but are included to show the other endpoint of transactions that ARE part of the profile (e.g., Query Reporting Worklist, Query/ Retrieve Reports and Query/ Retrieve Images). As a result, the shaded actors are not listed in Table 4.1-1.

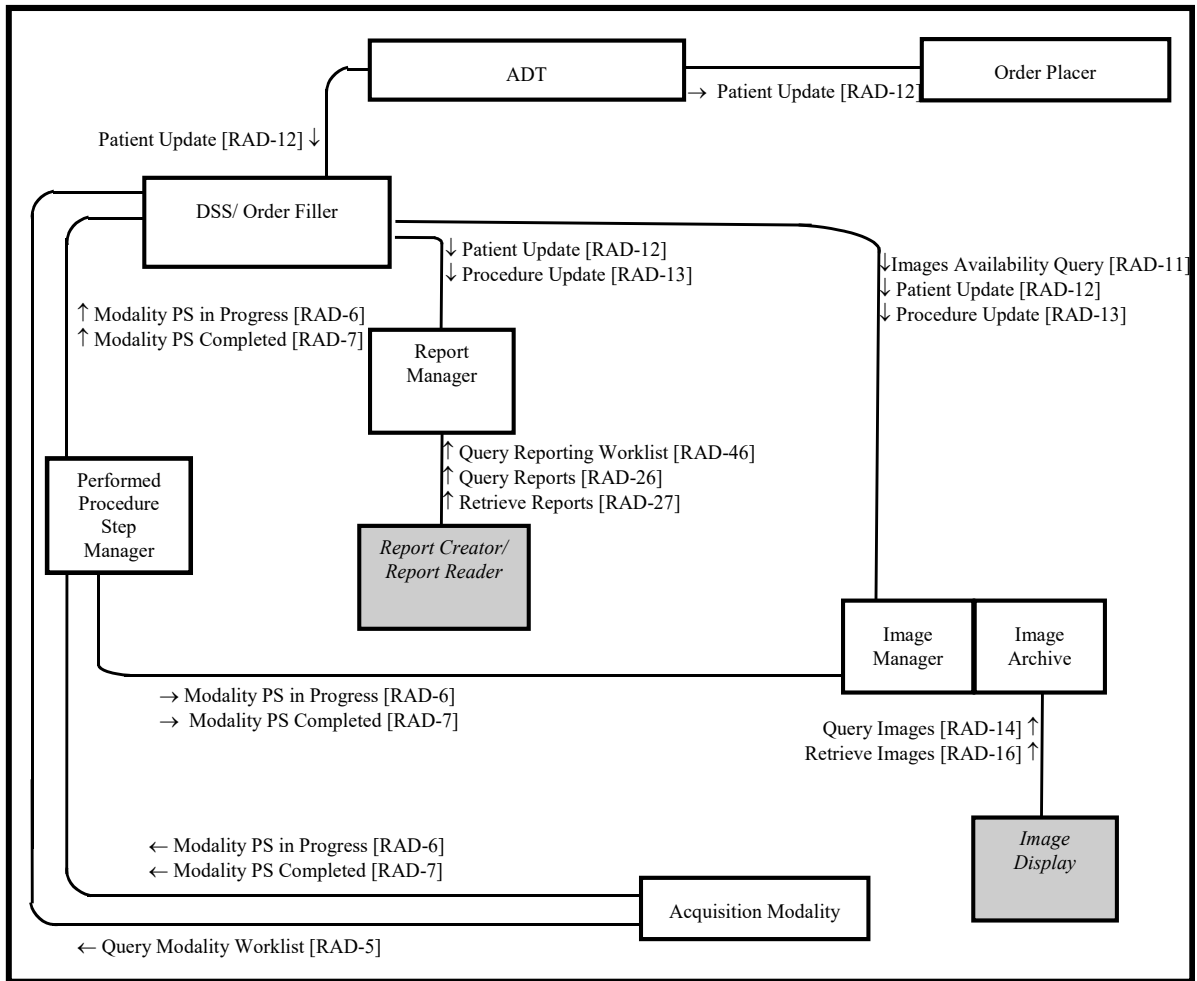

Figure 4.1-1: Patient Information Reconciliation Diagram

1935

1940

Table 4.1-1 lists the transactions for each actor directly involved in the Patient Information Reconciliation Integration Profile. In order to claim support of this Integration Profile, an implementation must perform the required transactions (labeled “R”). Transactions labeled “O” are optional. A complete list of options defined by this Integration Profile that implementations may choose to support is listed in Section 4.2.

Table 4.1-1: Patient Information Reconciliation - Actors and Transactions

Actors	Transactions	Optionality	TF Reference
ADT Patient Registration	Patient Update [RAD-12]	R	RAD TF-2: 4.12
Order Placer	Patient Update [RAD-12]	R	RAD TF-2: 4.12
Department System Scheduler/ Order Filler	Patient Update [RAD-12]	R	RAD TF-2: 4.12
	Procedure Update [RAD-13]	R	RAD TF-2: 4.13
	Query Modality Worklist [RAD-5]	R	RAD TF-2: 4.5
	Modality Procedure Step In Progress [RAD-6]	R	RAD TF-2: 4.6
	Modality Procedure Step Completed [RAD-7]	R	RAD TF-2: 4.7
	Images Availability Query [RAD-11]	O	RAD TF-2: 4.11
Acquisition Modality	Query Modality Worklist [RAD-5]	R	RAD TF-2: 4.5
	Modality Procedure Step In Progress [RAD-6]	R	RAD TF-2: 4.6
	Modality Procedure Step Completed [RAD-7]	R	RAD TF-2: 4.7
Image Manager/ Image Archive	Patient Update [RAD-12]	R	RAD TF-2: 4.12
	Procedure Update [RAD-13]	R	RAD TF-2: 4.13
	Modality Procedure Step In Progress [RAD-6]	R	RAD TF-2: 4.6
	Modality Procedure Step Completed [RAD-7]	R	RAD TF-2: 4.7
	Query Images [RAD-14]	R	RAD TF-2: 4.16
	Retrieve Images [RAD-16]	R	RAD TF-2: 4.16
	Images Availability Query [RAD-11]	R	RAD TF-2: 4.11
Performed Procedure Step Manager	Modality Procedure Step In Progress [RAD-6]	R	RAD TF-2: 4.6
	Modality Procedure Step Completed [RAD-7]	R	RAD TF-2: 4.7
Report Manager (optionally grouped with a Report Repository)	Patient Update [RAD-12]	R	RAD TF-2: 4.12
	Procedure Update [RAD-13]	R	RAD TF-2: 4.13
	Query Report [RAD-26]	R	RAD TF-2: 4.26
	Retrieve Reports [RAD-27]	R	RAD TF-2: 4.27
	Query Reporting Worklist [RAD-46]	R	RAD TF-3: 4.46

Refer to Table 2-1 for other profiles that may be pre-requisites for this profile.

1945 Note that this is an enhancing profile. Actors must perform reconciliation for all other profiles they support.

1950 Where the actor entry in the table refers to another *integration profile* (e.g., *Scheduled Workflow*), all required transactions in the referenced profile for that actor must be implemented. Some of these transactions in the referenced integration profile (for example the Department System Scheduler responsibilities in the Patient Update transaction) are extended as specified in Volume 2 and Volume 3.

1955 To support the Patient Information Reconciliation Profile, an actor that claims support of other content profiles (Consistent Presentation of Images, Key Image Notes, Simple Image & Numeric Reports or Evidence Documents) is required to support reconciliation of the relevant Evidence Objects. The following diagrams will mostly show the management/ reconciliation of images.

1960 The Report Manager must update existing workitems based on the patient information update but since the report content is not modified the rest of the reporting workflow is not affected. In other words, no additional reporting workitems will be scheduled or cancelled because of this update. The report status is also not affected e.g., a verified report in which the patient information has been updated remains verified. This profile does not require notification of other actors about the patient update.

1965 In case of DICOM SR, the patient information might be included in the content sequence. The update of the patient information in the report header might result in inconsistent header information with the report content. The patient information update shall not create a new SR SOP instance, according to DICOM SR SOP Class behavior as described in DICOM PS3.4, Annex O.

4.2 Patient Information Reconciliation Integration Profile Options

Options that may be selected for this Integration Profile are listed in the Table 4.2-1 along with the actors to which they apply.

Table 4.2-1: Patient Information Reconciliation – Actors and Options

Actor	Options	TF Reference
ADT Patient Registration	HL7 v2.5.1	RAD TF-1: 4.2.1 RAD TF-2: 4.12
Order Placer	HL7 v2.5.1	RAD TF-1: 4.2.1 RAD TF-2: 4.12
DSS/Order Filler	HL7 v2.5.1	RAD TF-1: 4.2.1 RAD TF-2: 4.12 RAD TF-2: 4.13
Acquisition Modality	<i>No options defined</i>	-
Image Manager/ Image Archive	HL7 v2.5.1	RAD TF-1: 4.2.1 RAD TF-2: 4.12 RAD TF-2: 4.13
Performed Procedure Step Manager	<i>No options defined</i>	-

Actor	Options	TF Reference
Report Manager	HL7 v2.5.1	RAD TF-1: 4.2.1 RAD TF-2: 4.12 RAD TF-2: 4.13

1970 **4.2.1 HL7 v2.5.1 Option**

The HL7 v2.5.1 Option requires actors to support HL7 v2.5.1 in addition to HL7 v2.3.1 in the transactions referenced in Table 4.2-1. The actor shall permit configuration for each system that it communicates with using the referenced transactions whether HL7 v2.3.1 or HL7 v2.5.1 is used. It is possible that the actor may receive HL7 v2.3.1 messages and send HL7 v2.5.1 messages or vice versa.

1975

The specifications in the HL7 v2.5.1 Option maintain semantic equivalency with HL7 v2.3.1 implementations and the field correspondences are summarized in RAD TF-2: Appendix E.

4.3 Unidentified Patient Image Acquisition and Reconciliation

1980

This section describes the general process flow related to the handling of procedures for unidentified patients. The transactions covered are Patient Registration [RAD-1], Placer Order Management [RAD-2], Procedure Scheduled [RAD-4], MWL Provided [RAD-5], Modality Procedure Step In Progress [RAD-6], Modality Procedure Step Completed/Discontinued [RAD-7], Patient Update [RAD-12], and Procedure Update [RAD-13].

1985

The Unidentified Patient case covers the trauma case or emergency room patient when a patient's condition requires that a procedure be conducted immediately. This is done before proper patient registration, ordering and/or scheduling of the procedure are performed (due to the lack of either information or time or other deviation from the normal process flow). In this case patient/study information must be later reconciled and properly updated at the ADT, Order Placer, Department System Scheduler/Order Filler, Image Manager and Report Manager. There are several examples of information flow in this case. These examples are described in use cases (see Sections 4.4.1 – 4.4.5 for details):

1990

- Case 1: Unidentified Patient registered at ADT and ordered at Order Placer.
- Case 2: Unidentified Patient registered at ADT and ordered at Department System Scheduler/Order Filler.
- Case 3: Unidentified Patient registered at ADT but acquisition completed at Modality prior to order.

1995

2000

In cases 1, 2, and 3, the ADT may utilize the Master Patient Index (MPI) internally. The interaction of the ADT with MPI to resolve the patient information to the correct Patient ID may be embedded in the process of patient information reconciliation within the ADT role. The IHE Technical Framework in future years may define patient reconciliation transactions using MPI.

The Radiology Technical Framework also supports cases when registration or temporary registration of a patient by ADT is not applicable or desired, for example:

- 2005 • Emergency Department patient can be identified but, due to time or system availability constraints the procedure must be performed before proper order entry and scheduling may occur.
- Patient ID, though valid, has never been propagated to all actors due to communication failures, or the wrong patient record was used in ordering/scheduling.
- Patient ID, though valid, has been mistyped at the modality.
- 2010 • Patient cannot be registered at the ADT by the time of the procedure. The patient presents to the Order Filler Actor (Imaging Department) and the order is placed and performed in the department.

The following additional use cases are identified (see Sections 4.4.4 and 4.4.5):

- Case 4: Unidentified Patient assigned temporary Departmental ID and scheduled at Department System Scheduler/Order Filler.
- 2015 • Case 5: Image Acquisition completed without scheduling at Department System Scheduler/Order Filler.

2020 Cases 4 and 5 require patient reconciliation on the department level. In the case of procedures performed on the unidentified patient in multiple departments (e.g., Radiology and Laboratory), this will require reconciliation of patient information in multiple locations. To address this issue, the IHE Technical Framework in future years may define patient reconciliation transactions using Master Patient Index (MPI).

The Radiology Technical Framework also recognizes that the following 4-step case of handling unidentified patients may be utilized in certain installations:

- 2025 1. The patient is delivered to the department, where a temporary departmental Patient ID and/or name are assigned.
2. The order is then entered by the Department System Scheduler/Order Filler and with this Patient ID and/or name, and the procedure is performed on the Acquisition Modality.
- 2030 3. The Department System Scheduler/Order Filler sends a new order transaction to the Order Placer. This departmental Patient ID is shared by the Image Manager, Department System Scheduler/Order Filler and Order Placer. However, this departmental Patient ID is not known to the ADT.
- 2035 4. After resolution of the patient identity, the ADT registers/admits the patient with the correct Patient ID and sends a message to the Order Placer and Department System Scheduler/Order Filler. Each system locally merges the new record with the existing one identified by the departmental Patient ID.

Because this case requires reconciliation at multiple points throughout the enterprise, IHE does not recommend this workflow.

4.3.1 Patient Information Reconciliation during Image Acquisition

2040 This section describes the general process flow related to the handling of procedures for image acquisition ongoing during patient reconciliation. The transactions covered are Patient

2045 Registration [RAD-1], Placer Order Management [RAD-2], Procedure Scheduled [RAD-4], MWL Provided [RAD-5], Modality Procedure Step In Progress [RAD-6], Modality Procedure Step Completed/Discontinued [RAD-7], Patient Update [RAD-12], Procedure Update [RAD-13], Query Images [RAD-14], Query Presentation States [RAD-15], Retrieve Images [RAD-16] and Retrieve Presentation States [RAD-17].

2050 When a Patient Update occurs, in addition to the information exchange between the ADT, Order Placer and Department System Scheduler/Order Filler, Patient Update information is also sent to the Image Manager. Even after a Patient Update has occurred images coming from the Modality may continue to use the original Patient Information, so on-going Patient update with incoming images from the modality may be necessary. It is the responsibility of the Image Manager to ensure that the patient information is updated in the images, Grayscale Softcopy Presentation States and other Evidence Objects when they are retrieved from the Image Archive. This example is described in use case 6 (see Section 4.4.6).

4.4 Use Cases

2055 The following sections describe the Unidentified Patient use cases. For the purpose of simplification, the following transactions were omitted from the corresponding diagrams:

- Modality Performed Procedure Step In Progress [RAD-6]
- Modality Images Stored [RAD-8]
- Modality Presentation State Stored [RAD-9]
- 2060 • Storage Commitment [RAD-10]

These transactions may occur within the time frame of the diagram, but their content does not affect each of the use cases.

4.4.1 Case 1: Unidentified Patient Registered at ADT and Ordered at the Order Placer

2065 The ADT is a single point of patient reconciliation in the enterprise. Process flow requires that any unidentified patient be assigned a permanent Patient ID and a temporary name (e.g., “John Doe”). All subsequent transactions follow the normal flow (see Section 3.1) including order entry and procedure scheduling. When the real patient identity is known, the ADT is responsible for reconciliation of its own records as well as informing the Order Placer and Department System Scheduler/Order Filler about corresponding changes. The ADT sends a Patient Update message to both the Order Placer and Department System Scheduler/Order Filler. The Department System Scheduler/Order Filler sends the Patient Update message to the Image Manager and the Report Manager.

2070

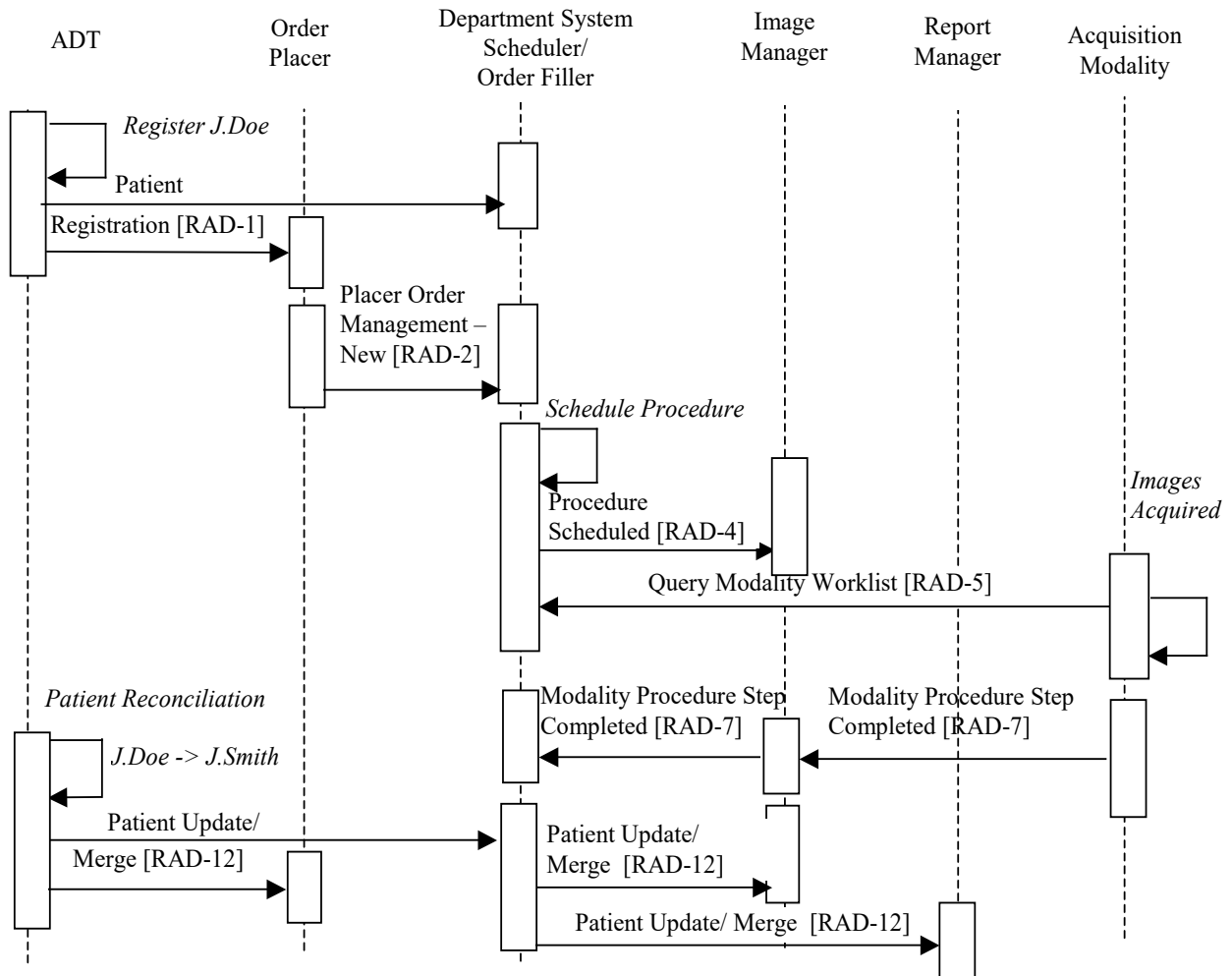

2075

Figure 4.4-1: Unidentified Patient– Case 1

Significant Transactions:

- To reconcile the patient information, the ADT may register a new patient and merge the temporary patient with the correct patient and send both Patient Registration [RAD-1] and Patient Update [RAD-12] (Merge) transactions.
- If a permanent Patient ID was assigned, then the ADT may only send a Patient Update [RAD-12] transaction with proper information.

2080

Note that the Performed Procedure Step Manager is not shown on the Process Flow diagrams and is presumed to be grouped with the Image Manager. It may be grouped with the Department System Scheduler/Order Filler with corresponding changes in the flow of PPS related transactions between the Image Manager and Department System Scheduler/Order Filler.

2085

4.4.2 Case 2: Unidentified Patient Registered at ADT and Ordered at Department System Scheduler/Order Filler

2090 This case is based on case 1. However, in this situation the order for a procedure is generated by the Department System Scheduler/Order Filler and submitted to the Order Placer. Procedures are scheduled normally and image acquisition uses modality worklist. When the patient information is reconciled, the ADT sends the Patient Update messages to both the Order Placer and Department System Scheduler/Order Filler. The Department System Scheduler/Order Filler sends the Patient Update message to the Image Manager and the Report Manager.

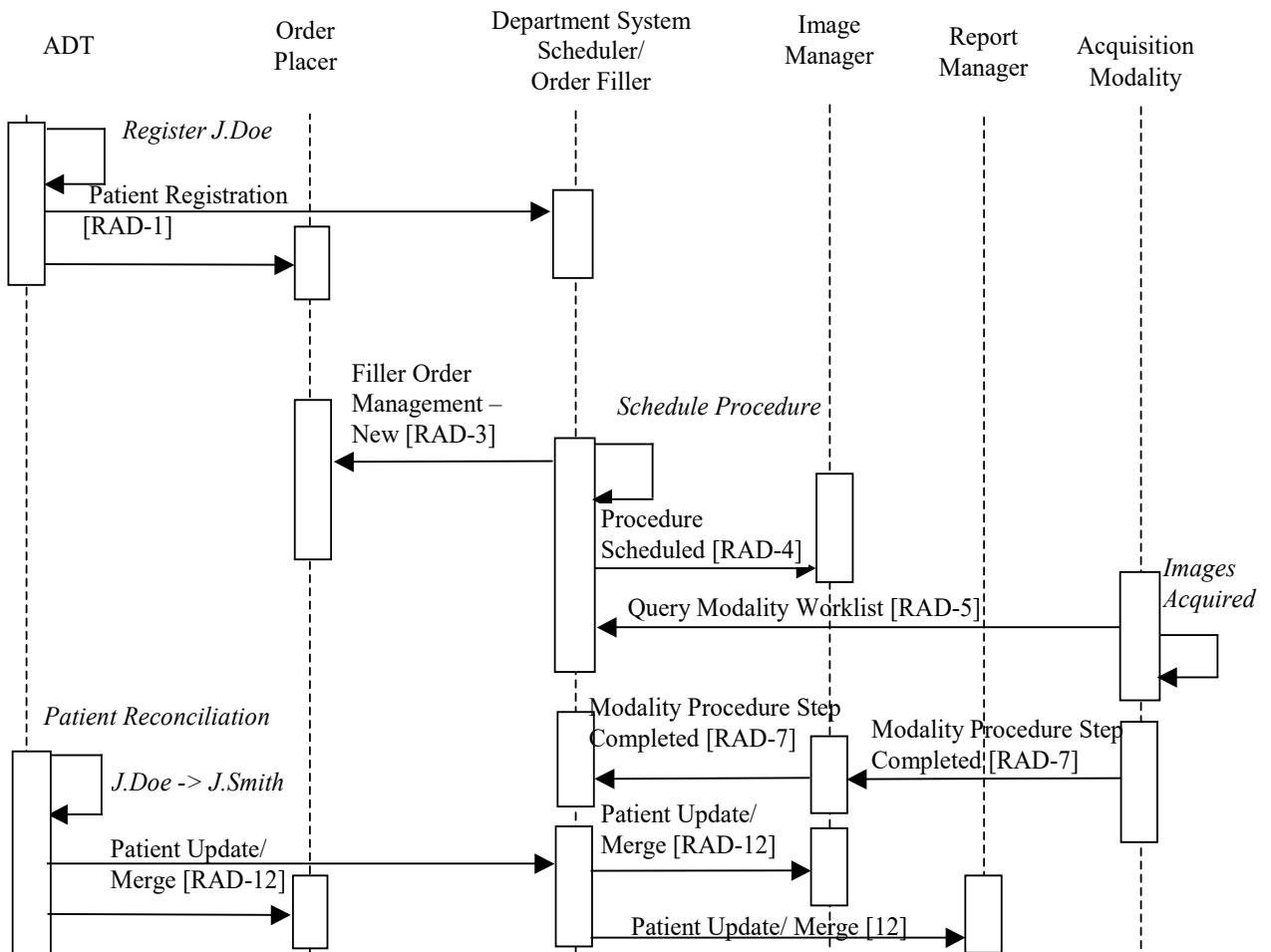

2095

Figure 4.4-2: Unidentified Patient– Case 2

Significant Transactions:

- 2100 • To reconcile the patient information, the ADT may register a new patient and merge the temporary patient with the correct patient and send both registration and merge transactions.
- If a permanent Patient ID was assigned, then the ADT may only send a Patient Update transaction with proper information.
- 2105 • A Filler Order Management (New Order) [RAD-3] transaction is sent from Department System Scheduler/Order Filler to the Order Placer.

4.4.3 Case 3: Unidentified Patient Registered at ADT but Completed at Modality Prior to Order

2110 As in cases 1 and 2, this uses a permanent Patient ID generated by the ADT. However, no order entry or scheduling takes place before the Acquisition Modality performs the procedure. A permanent Patient ID and a temporary name are manually entered at the Acquisition Modality (typically, from a card) and conveyed to the Department System Scheduler/Order Filler and the Image Manager by the Acquisition Modality. Subsequently, the Department System Scheduler/Order Filler generates and submits an order to the Order Placer. When the patient information is reconciled, the ADT sends the Patient Update messages to both the Order Placer and the Department System Scheduler/Order Filler. The Department System Scheduler/Order Filler sends a Patient Update message to the Image Manager and the Report Manager.

2115

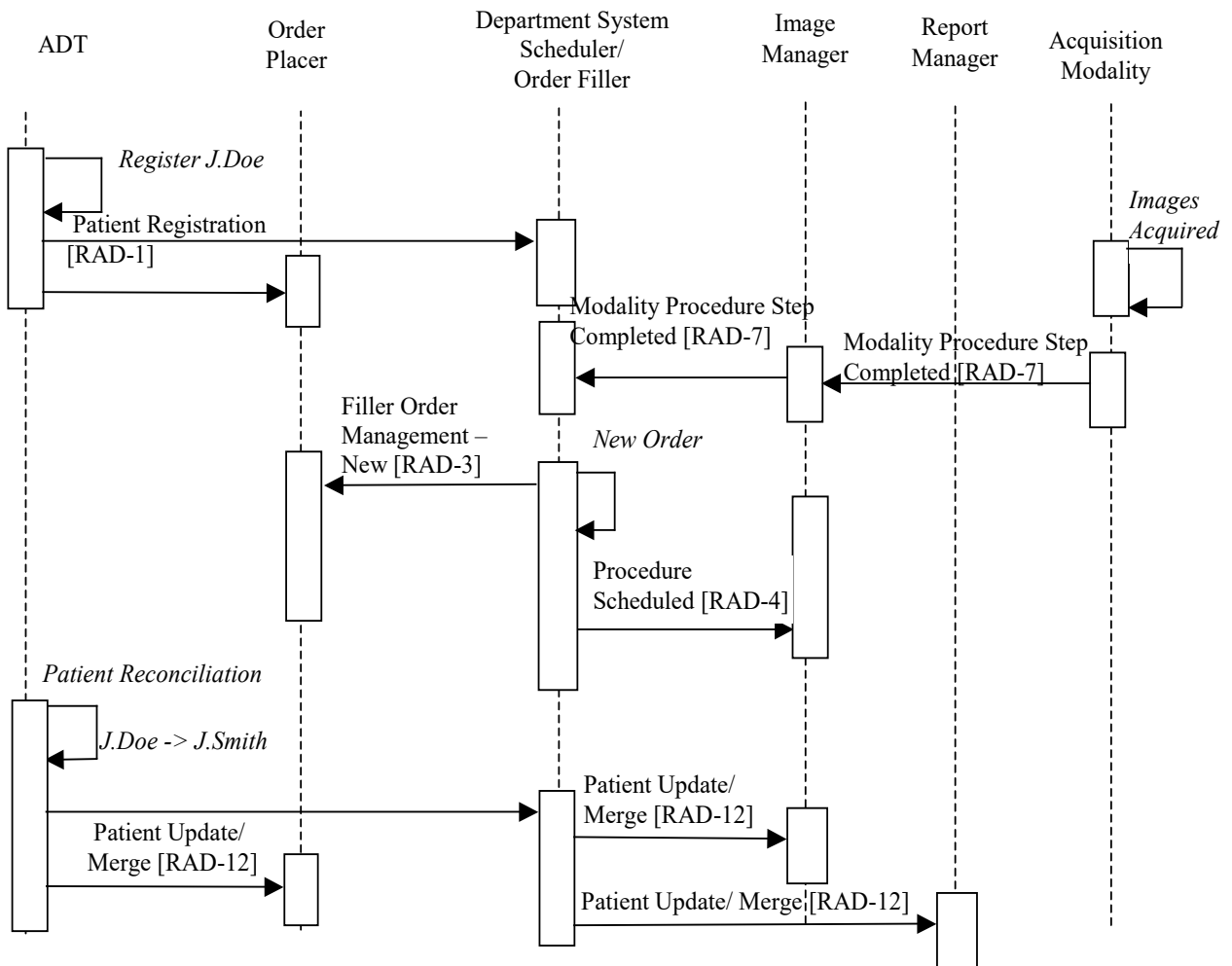

Figure 4.4-3: Unidentified Patient– Case 3

2120 Significant Transactions:

- On receiving a Modality Procedure Step Completed [RAD-7], the Department System Scheduler/Order Filler recognizes it as an unscheduled case.
- The Department System Scheduler/Order Filler sends a Filler Order Management (New Order) [RAD-3] transaction to the Order Placer.

2125

- Using the information from the Procedure Step Completed transaction and the placed order, the DSS/Order Filler creates a new Requested Procedure record and sends a Procedure Scheduled transaction to the Image Manager.

2130

- To reconcile the patient information, the ADT may register a new patient and merge the temporary patient with the correct patient and send both registration and merge transactions.

- If a permanent Patient ID was assigned, then the ADT may only send a Patient Update transaction with proper information.
- The DSS/Order Filler sends a Patient Update transaction to the Image Manager.

2135 **4.4.4 Case 4: Unidentified Patient Assigned Temporary Departmental ID and Scheduled at DSS/Order Filler**

In this case, no valid Patient ID is available to the Department System Scheduler/Order Filler. It assigns a temporary Patient ID and a temporary name and schedules the required procedure.

Note: The Department System Scheduler/Order Filler must ensure that the assigned temporary Patient ID is unique within its scope.

2140 The temporary Patient ID is conveyed to the Image Manager. When patient information becomes known, the ADT sends new patient information to both the Order Placer and the Department System Scheduler/Order Filler. The Department System Scheduler/Order Filler reconciles received patient information with that associated with the temporary Patient ID and merges the permanent patient record with its own temporary one and sends a Patient Update transaction to the Image Manager and the Report Manager. At the same time, the Department System Scheduler/Order Filler generates and submits an order to the Order Placer using a permanent Patient ID.

2145

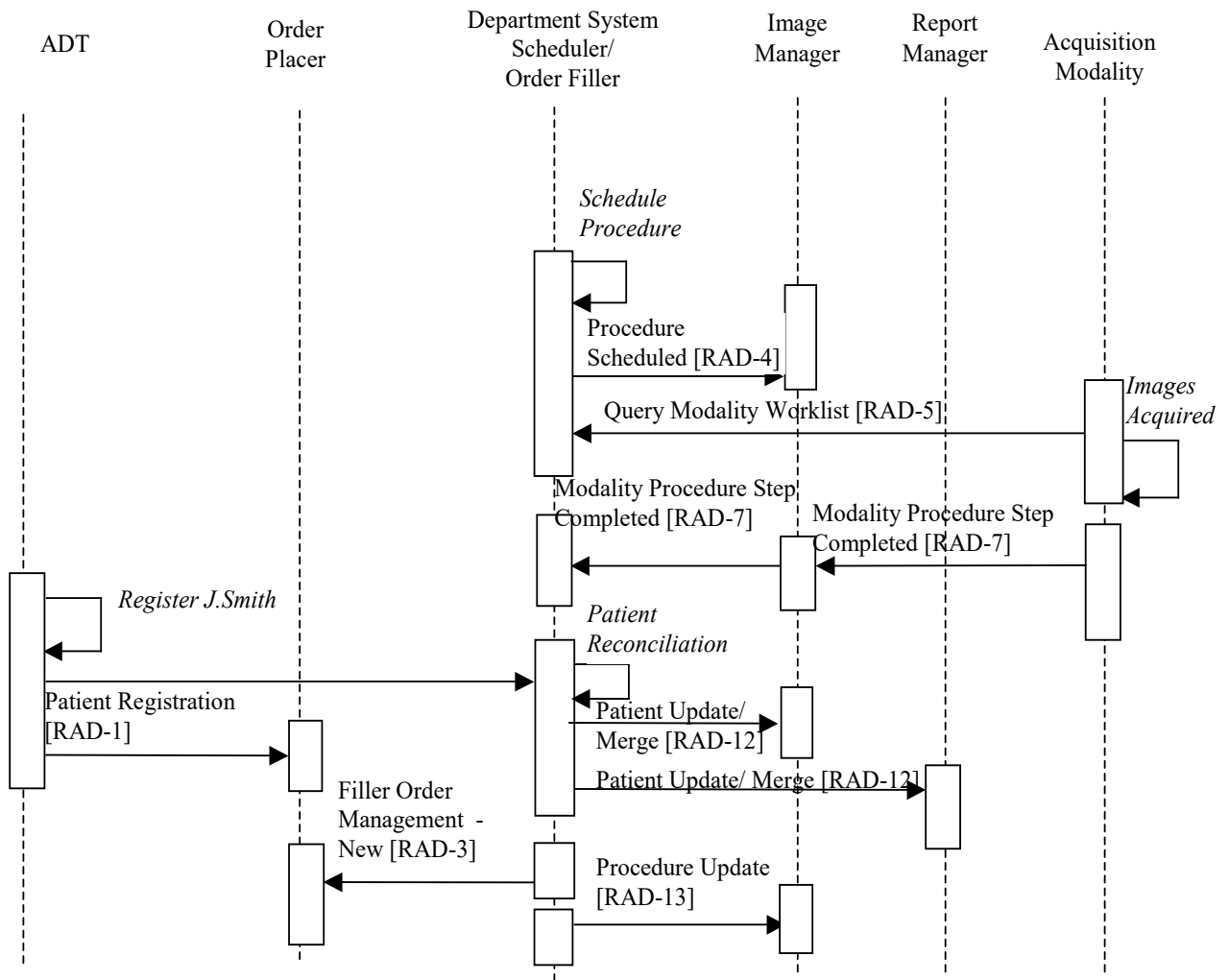

Figure 4.4-4: Unidentified Patient– Case 4

2150 Significant Transactions:

- Patient information is reconciled internally by the Department System Scheduler/Order Filler using the Patient Registration from ADT.
- The Department System Scheduler/Order Filler sends the Patient Update [RAD-12] transaction to the Image Manager.

2155

- The Department System Scheduler/Order Filler sends the Filler Order Management (New Order) [RAD-3] transaction to the Order Placer.

4.4.5 Case 5: Image Acquisition Completed Without Scheduling at Department System Scheduler/Order Filler

2160 In this case, no valid Patient ID is available to the Department System Scheduler/Order Filler and no scheduling is done before the procedure is performed. A temporary ID and name are entered

2165 by the technologist at the Modality and conveyed to the Department System Scheduler/Order Filler and to the Image Manager. The Patient ID and name are selected by the technologist according to the locally defined rules; for example, selected from the predefined pool of “Patient ID–patient name” pairs. The rules for selecting temporary Patient ID shall guarantee its uniqueness within the scope of Department System Scheduler/Order Filler.

2170 Upon receiving the Modality Procedure Step Completed message, the DSS/Order Filler and Image Manager recognize an unscheduled case based on the content of the message (absent or empty Referenced Study Sequence, see RAD TF-2: Appendix A). When patient information becomes known, the ADT sends the new patient information to both the Order Placer and Department System Scheduler/Order Filler. The Department System Scheduler/Order Filler performs a merge of the permanent patient record with the temporary one and sends a Patient Update to the Image Manager and the Report Manager. At the same time, Department System Scheduler/Order Filler generates and submits an order to the Order Placer using a valid Patient ID.

2175

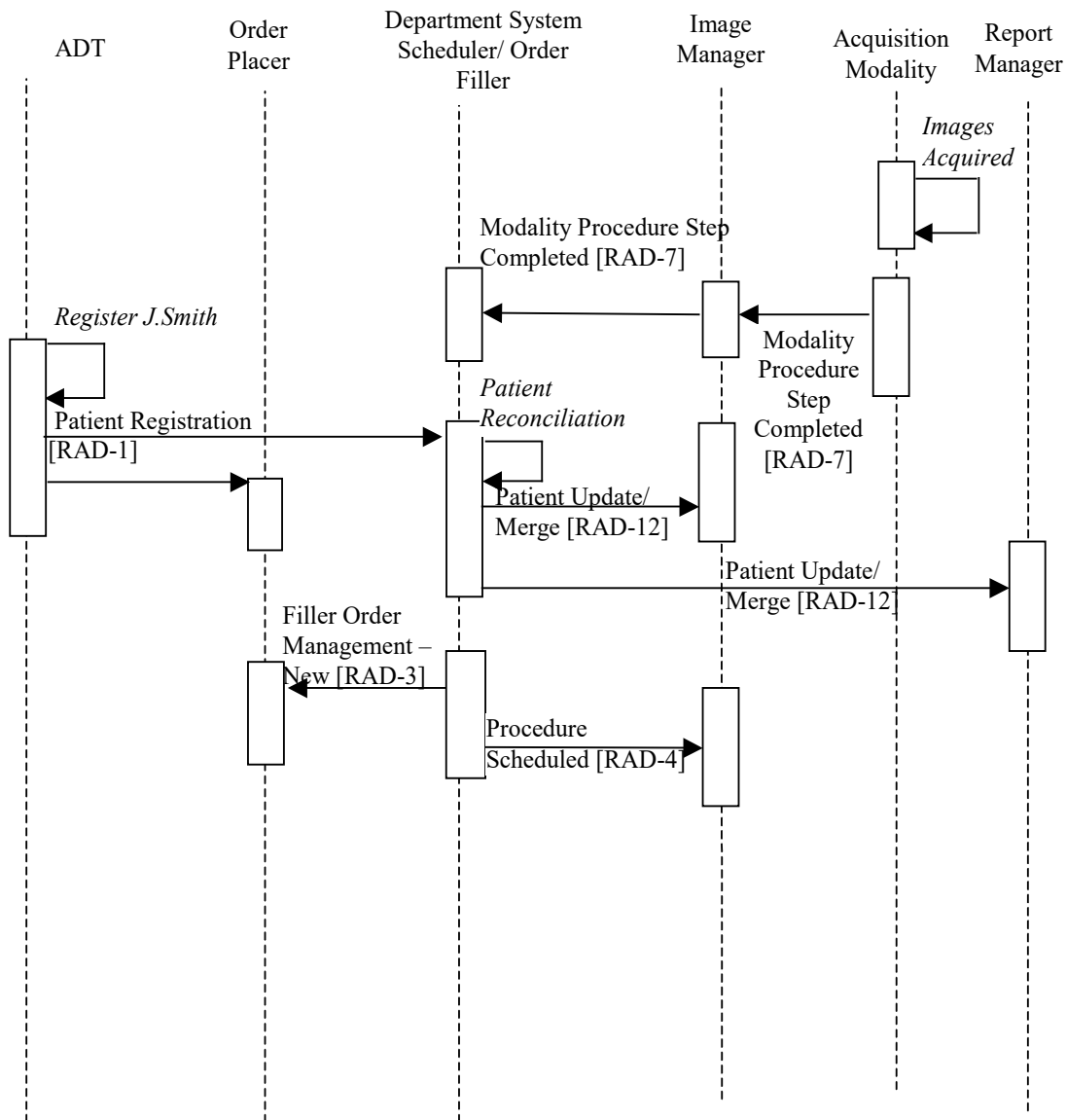

Figure 4.4-5: Unidentified Patient – Case 5

Significant Transactions:

2180

- On receiving a Procedure Step Completed transaction, the Department System Scheduler/Order Filler recognizes it as an unscheduled case.
- Patient information is reconciled internally by the Department System Scheduler/Order Filler using the Patient Registration from the ADT.
- The Department System Scheduler/Order Filler sends a Patient Update (Merge) transaction to the Image Manager and to the Report Manager.

- 2185
- The Department System Scheduler/Order Filler sends a Filler Order Management (New Order) [RAD-3] transaction to the Order Placer.
 - Using the information from the Procedure Step Completed transaction and placed order, the Department System Scheduler/Order Filler creates a new Requested Procedure record and sends a Procedure Scheduled [RAD-4] transaction to the Image Manager and Report Manager.
- 2190

4.4.6 Case 6: Patient Information Reconciliation During Image Acquisition

2195 Updates may need to occur after the initial Patient Registration and Order Placement has occurred. The Modality may have requested information from the Department System Scheduler before the update has occurred and continue to send the images with the original Patient Registration and Order information. The Image Manager will need to continue updating the patient information from items retrieved from the Image Archive.

Significant Transactions:

- The Modality may continue to send information using the original patient information even after the patient update has occurred.
 - The Image Manager must continue reconciling Patient Information even after the Patient Update transaction has been completed.
- 2200

Only partial transactions are shown. Other transactions are performed according to the profile requirements.

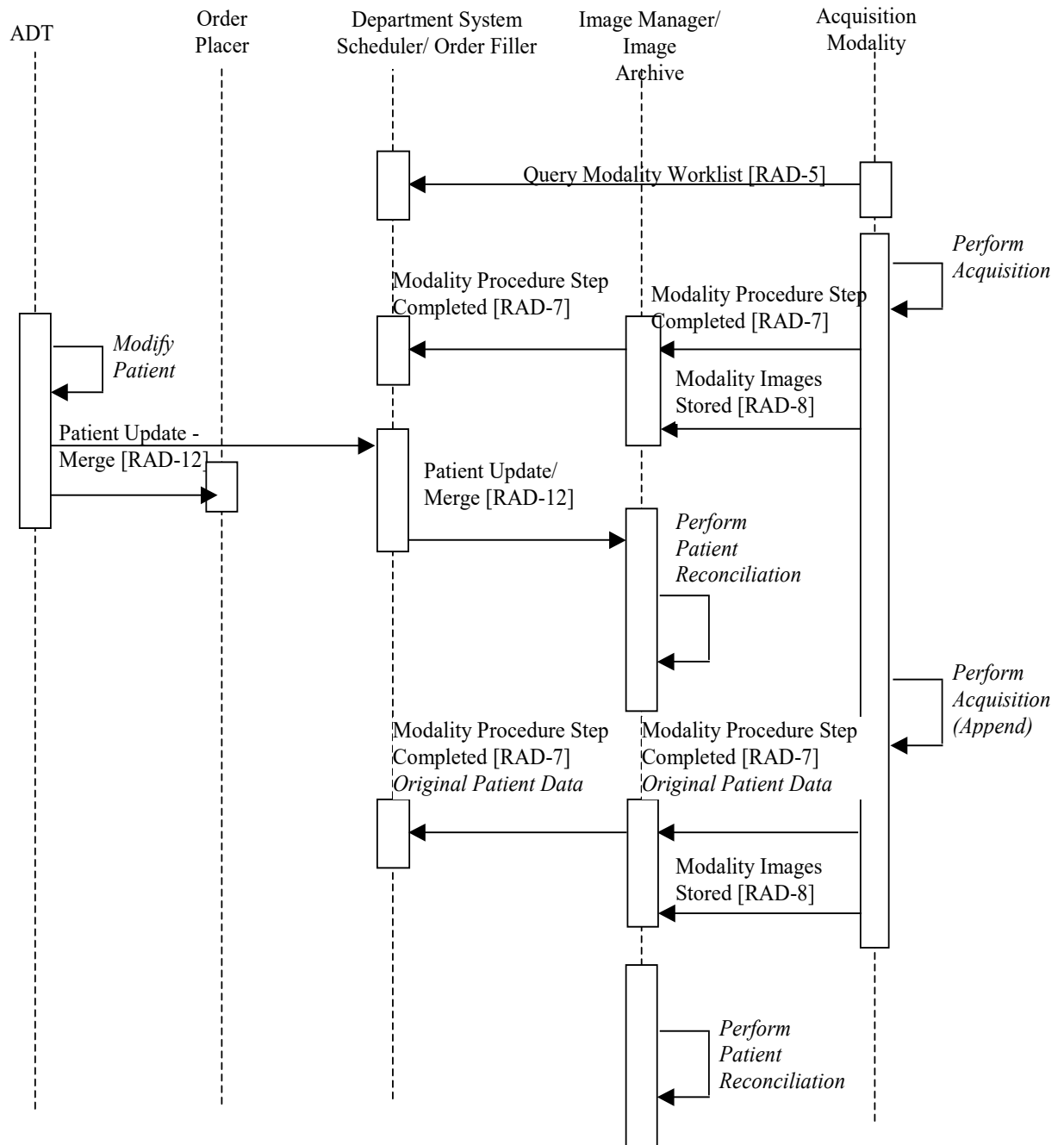

2205

Figure 4.4-6: Patient Information Reconciliation During Image Acquisition

5 Consistent Presentation of Images (CPI)

2210 The *Consistent Presentation of Images Integration Profile* specifies a number of transactions that maintain the consistency of presentation for grayscale images. The presentation of images depends upon the contrast/brightness and the spatial and graphical operations applied, such as user annotations, shutters, flip/rotate, display area selection, and zoom. The spatial and graphical operations are defined in the Grayscale Softcopy Presentation State. For the consistency of the perceived pixel intensity a standard contrast curve, the Grayscale Standard Display Function, has
2215 been defined against which different types of display and hardcopy output devices are calibrated. This profile is intended to establish consistency between any combination of softcopy and hardcopy displays. In order to guarantee both grayscale contrast/brightness consistency and spatial/ graphical consistency in presentation of images it is required that both the Grayscale Standard Display Function and the Grayscale Softcopy Presentation State are supported.

2220 Note that this Integration Profiles applies only to grayscale images, and is not applicable for color images.

The Scheduled Workflow Profile or Post-Processing Profile, when combined with this profile, allows the process of creating, storing and accessing Presentation States to be managed using
2225 worklist to provide the relevant patient and procedure details; and using performed procedure steps to provide status information.

5.1 Actors/Transactions

Figure 5.1-1 diagrams the actors involved with this profile and the transactions between actors.

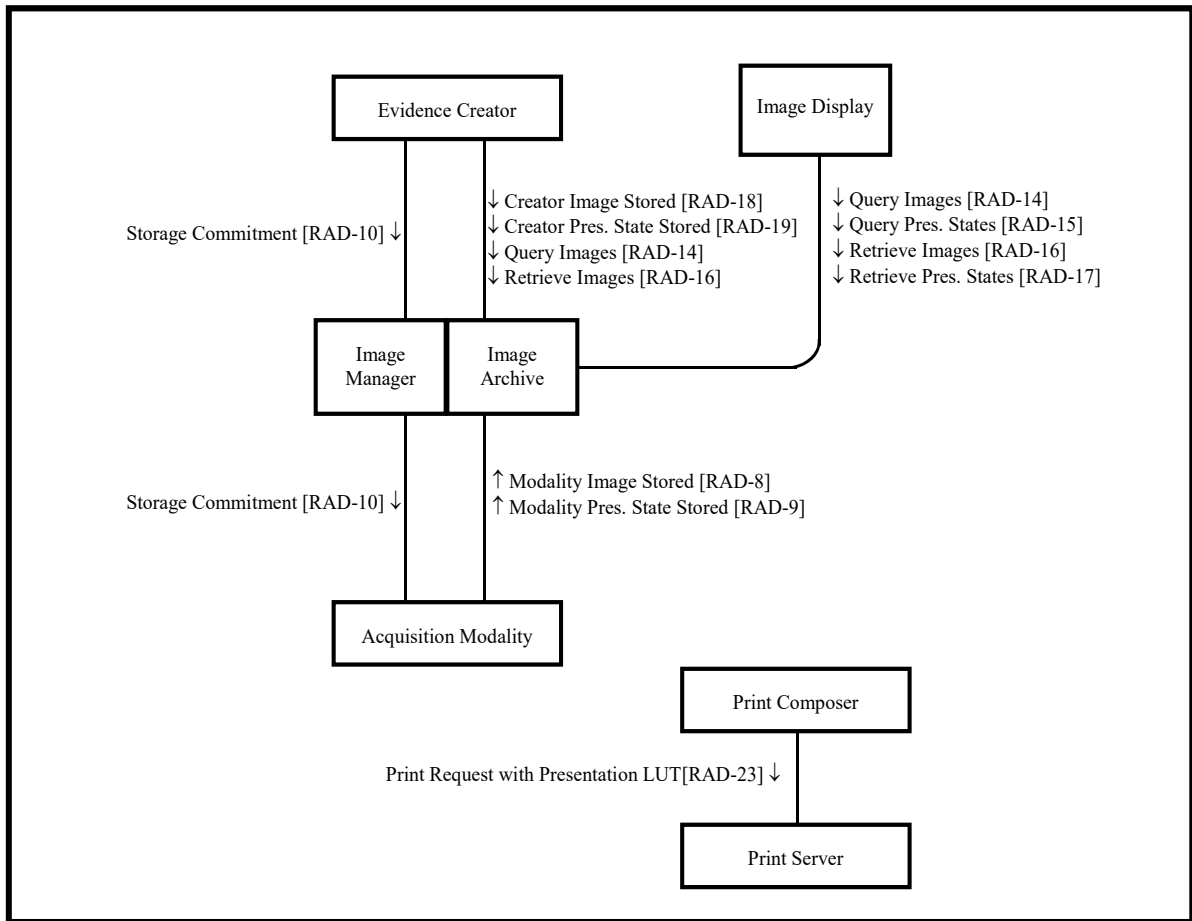

2230

Figure 5.1-1: Consistent Presentation of Images Diagram

Table 5.1-1 lists the transactions for each actor directly involved in the Consistent Presentation of Images Integration Profile. In order to claim support of this Integration Profile, an implementation must perform the required transactions (labeled “R”). Transactions labeled “O” are optional. For a complete list of options defined by this Integration Profile and that implementations may choose to support are listed in Section 5.2.

2235

Table 5.1-1: Consistent Presentation of Images - Actors and Transactions

Actors	Transactions	Optionality	TF Reference
Acquisition Modality	Modality Images Stored [RAD-8]	R	RAD TF-2: 4.8
	Storage Commitment [RAD-10]	R	RAD TF-2: 4.10
	Modality Presentation State Stored [RAD-9]	R	RAD TF-2: 4.9
Image Manager/ Image Archive	Modality Images Stored [RAD-8]	R	RAD TF-2: 4.8
	Storage Commitment [RAD-10]	R	RAD TF-2: 4.10
	Query Images [RAD-14]	R	RAD TF-2: 4.14
	Retrieve Images [RAD-16]	R	RAD TF-2: 4.16

Actors	Transactions	Optionality	TF Reference
	Creator Images Stored [RAD-18]	R	RAD TF-2: 4.18
	Modality Presentation State Stored [RAD-9]	R	RAD TF-2: 4.9
	Query Presentation States [RAD-15]	R	RAD TF-2: 4.15
	Retrieve Presentation States [RAD-17]	R	RAD TF-2: 4.17
	Creator Presentation State Stored [RAD-19]	R	RAD TF-2: 4.19
Image Display	Query Images [RAD-14]	R	RAD TF-2: 4.14
	Retrieve Images [RAD-16]	R	RAD TF-2: 4.16
	Query Presentation States [RAD-15]	R	RAD TF-2: 4.15
	Retrieve Presentation States [RAD-17]	R	RAD TF-2: 4.17
Evidence Creator	Creator Images Stored [RAD-18]	O	RAD TF-2: 4.18
	Creator Presentation State Stored [RAD-19]	R	RAD TF-2: 4.19
	Storage Commitment [RAD-10]	R	RAD TF-2: 4.10
	Query Images [RAD-14]	O	RAD TF-2: 4.14
	Retrieve Images [RAD-16]	O	RAD TF-2: 4.16
Print Composer	Print Request with Presentation LUT [RAD-23]	R	RAD TF-2: 4.23
Print Server	Print Request with Presentation LUT [RAD-23]	R	RAD TF-2: 4.23

Note: Refer to Table 2-1 for other profiles that may be pre-requisites for this profile.

5.2 Consistent Presentation of Images Integration Profile Options

Options that may be selected for this Integration Profile are listed in the Table 5.2-1 along with the Actors to which they apply. Dependencies between options when applicable are specified in notes.

Table 5.2-1: Consistent Presentation of Images – Actors and Options

Actor	Options	TF Reference
Acquisition Modality	<i>No options defined</i>	-
Image Manager/ Image Archive	<i>No options defined</i>	-
Image Display	<i>No options defined</i>	-
Evidence Creator	<i>No options defined</i>	-
Print Composer	User Specifiable Lighting Condition	RAD TF-2: 4.23.4.2.4
Print Server	<i>No options defined</i>	-

5.3 Consistent Presentation of Images Process Flow

2245 This section describes the typical process flow related to viewing images with Grayscale Softcopy Presentation States and performing image post-processing that may generate new images and/or Grayscale Softcopy Presentation States. The transactions covered are [RAD-14] through [RAD-22].

Consistent Presentation of Images is an integration feature that provides access to images with their full-fidelity content as they were acquired or created. Such access is available either:

- 2250
- Internally to the source imaging department;
 - Between imaging departments (e.g., Cardiology and Radiology); or
 - Throughout the Healthcare Enterprise to other departments or care providers other than an imaging department (e.g., Surgery, Neurology, Oncology).

2255 Consistent Presentation of Images enables advanced review as well as simple or sophisticated post-processing of images along with related objects (such as Grayscale Softcopy Presentation States, or Structured Reports) in a variety of clinical scenarios. Examples include the following:

- Based on patient identifying information, a clinician wishes to look for imaging studies performed on this patient. The clinician may access one or more series of images, related to a recent examination;
- 2260
- A reading physician performing a primary or secondary read wishes to retain viewing parameters including clinical annotations;
 - A clinician reviewing a report that references key images wishes to review those images;
 - A technologist about to perform an imaging examination wishes to retrieve a prior imaging examination to ensure consistent patient positioning;
- 2265
- A reading physician interpreting a study wishes to perform a comparison with images acquired in a prior study. The physician also needs to review the images as they were presented when a prior diagnosis was prepared; and
 - A surgeon creates a 3D volume analysis of an image set to plan surgery on a patient.

2270 The appearance of grayscale images displayed on different types of softcopy display devices or printed by different types of hardcopy output devices has often been inconsistent. To address this problem and achieve consistent presentation of grayscale images the DICOM Standard defines:

- A standard curve, the Grayscale Standard Display Function, against which different types of display and hardcopy output devices should be calibrated;
- 2275
- Basic Print Management with Presentation Look Up Table, for controlling the consistent appearance of preformatted images on printed output;
 - Grayscale Softcopy Presentation State, an object for storing and communicating the parameters that describe how an image or set of images shall be displayed. A Grayscale Softcopy Presentation State object contains references to the images it applies to, and the

2280

transformations (grayscale transformations, shutter transformations, image annotation, spatial transformations, and display area annotation) that shall be applied when the images are presented on a softcopy display.

The typical use of these capabilities is depicted in Figure 5.3-1.

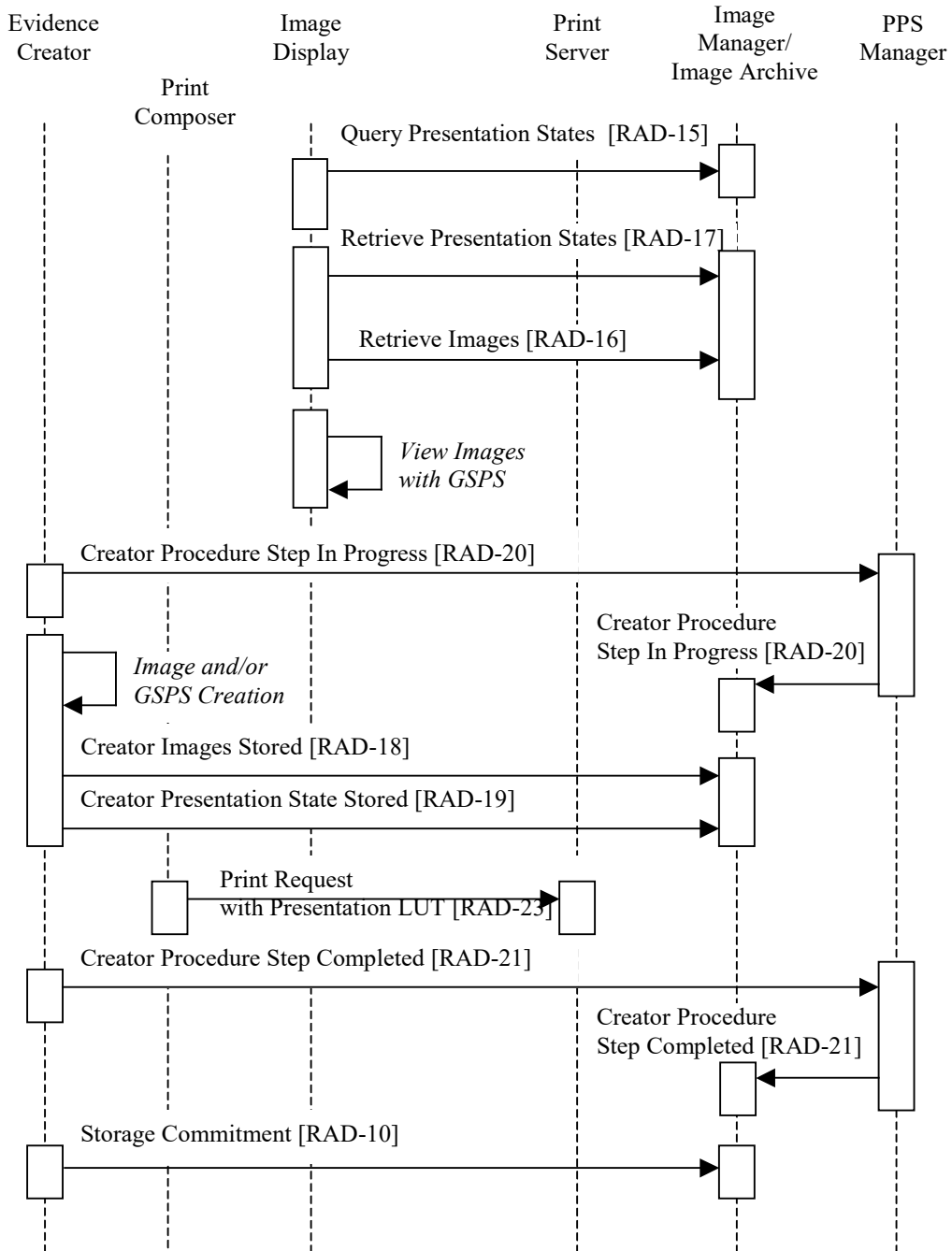

Figure 5.3-1: Consistent Presentation of Images Process Flow

- 2285 The following shall be taken into account in relation to the presented example of the Consistent Presentation of Images Process Flow:
- The Evidence Creator Actor shall be grouped with an Image Display Actor but is shown separately in the diagram above to distinguish the transactions;
 - In this example, the Print Composer is grouped with the Evidence Creator, but may be grouped with other actors that have access to images;
 - The diagram above includes Procedure Step transactions which are not part of this profile, but are defined the associated workflow profile. The diagram shows one particular sequencing of the Procedure Step Completed transaction. This transaction may occur at any point after image and/or Presentation State (GSPS) creation. This means it can occur before images and/or GSPS are stored, after storage, after printing as in this example, or even after storage commitment. The Radiology Technical Framework does not specify the timing of this transaction in relation to other transactions.
- 2290
- 2295

6 Presentation of Grouped Procedures (PGP)

2300 The *Presentation of Grouped Procedures Integration Profile (PGP)* addresses what is
 sometimes referred to as the linked studies problem: viewing image subsets resulting from a
 single acquisition with each image subset related to a different requested procedure (e.g., CT
 chest, abdomen and pelvis). It provides a mechanism for facilitating workflow when viewing
 2305 images and reporting on individual requested procedures that an operator has grouped (often for
 the sake of acquisition efficiency and patient comfort). A single acquired image set is produced,
 but the combined use of the scheduled workflow transactions and the consistent presentation of
 images allows separate viewing and interpretation of the image subsets related to each of the
 requested procedures.

6.1 Actors/Transactions

2310 Figure 6.1-1 diagrams the actors involved with this profile and the transactions between actors.

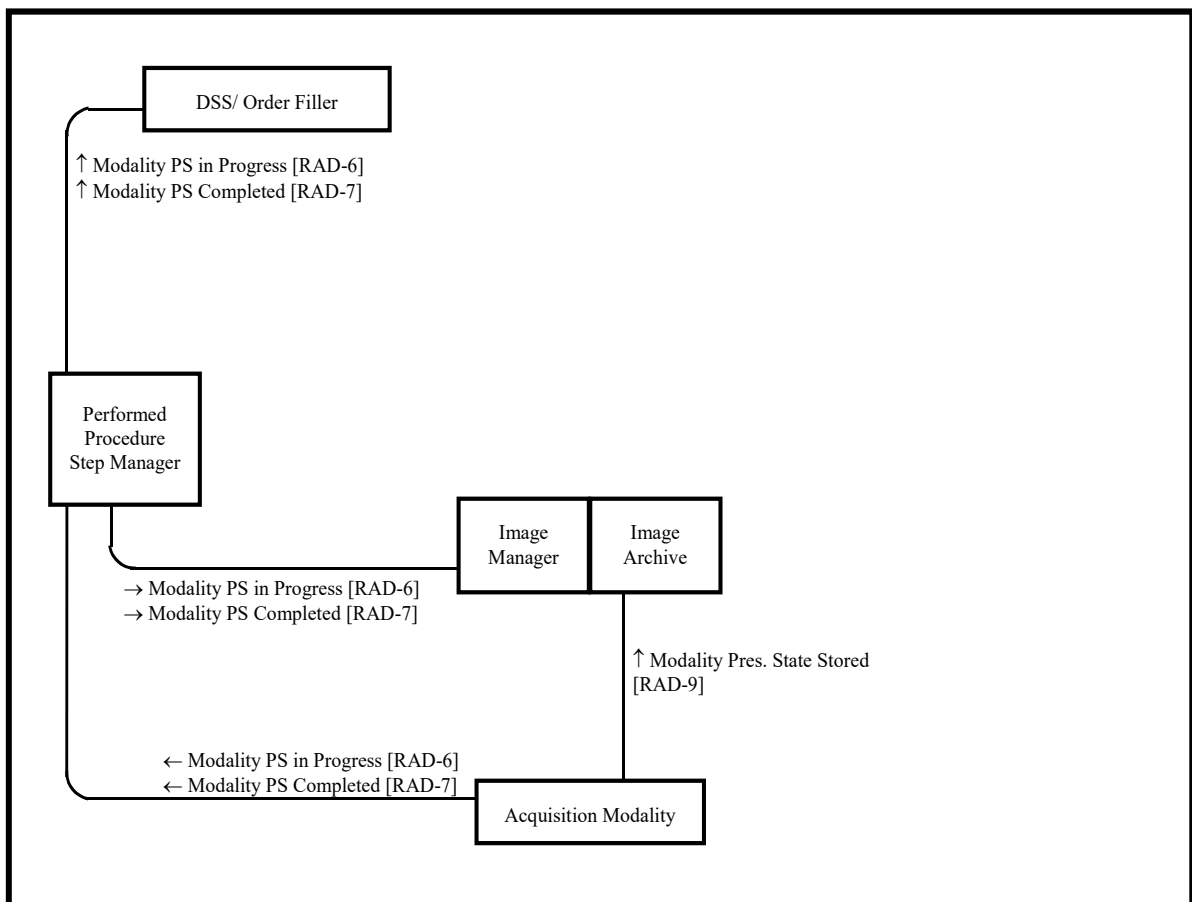

Figure 6.1-1: Presentation of Grouped Procedures Diagram

2315 Table 6.1-1 lists the required transactions for each actor directly involved in the Presentation of Grouped Procedures (PGP) Integration Profile. In order to claim support of this Integration Profile, an implementation must perform the required transactions (labeled “R”). Transactions labeled “O” are optional. A complete list of options defined by this Integration Profile and that implementations may choose to support is listed in Section 6.2.

Table 6.1-1: Presentation of Grouped Procedures - Actors and Transactions

Actors	Transactions	Optionality	TF Reference
Department System Scheduler/ Order Filler	Modality Procedure Step In Progress [RAD-6] (note 1)	R	RAD TF-2: 4.6
	Modality Procedure Step Completed [RAD-7]	R	RAD TF-2: 4.7
Acquisition Modality	Modality Procedure Step In Progress [RAD-6] (note 1)	R	RAD TF-2: 4.6
	Modality Procedure Step Completed [RAD-7]	R	RAD TF-2: 4.7
	Modality Presentation State Stored [RAD-9]	R	RAD TF-2: 4.9
Image Manager/ Image Archive	Modality Procedure Step In Progress [RAD-6] (See Note 1)	R	RAD TF-2: 4.6
	Modality Procedure Step Completed [RAD-7]	R	RAD TF-2: 4.7
	Modality Presentation State Stored [RAD-9]	R	RAD TF-2: 4.9
Performed Procedure Step Manager	Modality Procedure Step In Progress [RAD-6] (See Note 1)	R	RAD TF-2: 4.6
	Modality Procedure Step Completed [RAD-7]	R	RAD TF-2: 4.7

2320 Refer to Table 2-1 for other profiles that may be pre-requisites for this profile.

Note 1: This transaction has an extension that is required by this actor in this profile. This detailed definition of this extension is in RAD TF-2: 4.6.4.1.2.3.6.

2325 Note: The use of the integration capabilities offered by the IHE PGP Integration Profile (enabled by the Modality Procedure Step In Progress/Completed and the Modality Presentation State Stored) requires an Image Display to be integrated with other workflow-aware actors. Such actors may be an Image Manager/Archive or Department System Scheduler/Order Filler. A stand-alone Image Display cannot directly benefit from the PGP Integration Profile capabilities. However, if the stand-alone Image Display supports the Consistent Presentation of Images Integration Profile, it may benefit from the Presentation States generated by the Acquisition Modality implementing the PGP Integration Profile.

2330 6.2 Presentation of Grouped Procedures Integration Profile Options

Options that may be selected for this Integration Profile are listed in the Table 6.2-1 along with the Actors to which they apply.

Table 6.2-1: Presentation of Grouped Procedures – Actors and Options

Actor	Options	TF Reference
Acquisition Modality	<i>No options defined</i>	--
Department System Scheduler/ Order Filler	<i>No options defined</i>	--
Image Manager/Image Archive	<i>No options defined</i>	--
Performed Procedure Step Manager	<i>No options defined</i>	--

2335 6.3 Presentation of Group Procedures Process Flow

Presentation of Grouped Procedures (PGP) provides a mechanism for facilitating viewing images and reporting on individual Requested Procedures that have been fulfilled by a single Performed Procedure Step acquisition. The transactions covered are [RAD-5] through [RAD-10].

The following use case defines the PGP transaction flow:

- 2340 • When a number of Scheduled Procedure Steps, each corresponding to a different Requested Procedure, are grouped by a technologist and result in the acquisition of images forming a single Performed Procedure Step, the Presentation of these Grouped Procedures can be facilitated by the combined use of Grayscale Softcopy Presentation States and associated Performed Procedure Steps as defined below.
- 2345 • This also applies to Evidence Creators that retrieve images resulting from grouped procedures on the Acquisition Modality and for which presentation states may be defined specifically associated with one or more of the Requested Procedures.
- 2350 • For each of the Requested Procedures, the operator may create one or more Grayscale Softcopy Presentation States in order to define the corresponding viewing parameters applicable to a subset of images related to the Requested Procedure. These Grayscale Softcopy Presentation States shall be associated with a specific Performed Procedure Step related to the Requested Procedure.

The following example illustrates the PGP flow:

- 2355 • In this illustration, the grouping of chest, abdomen and pelvis Requested Procedures would result in one PPS related to the acquired images on a spiral CT scanner. Then the operator would select the chest subset of the acquired images, choose the appropriate window width/window level for the chest images and produce a GSPS recording the chest presentation state. A Procedure Step Completed transaction related to this chest view would then be sent to the Image Manager and to the Department System Scheduler/Order Filler. Likewise for the abdomen and the pelvis, thus resulting in four PPS, one for the images of the three grouped procedures and three PPS each related to the presentation states. Finally, the images and GSPSs are stored in the Image Archive and Storage Commitment is performed.
- 2360 • A reading physician may use the GSPSs (associated with the Requested Procedure indicated in the PPS transaction) created by the technologist to facilitate viewing and

interpreting the CT chest images separately from the CT abdomen images. This will facilitate interpretation as well as reviewing the relevant subset of prior images.

The following sequence of steps describes the typical process flow involved in Presentation of Grouped Procedures:

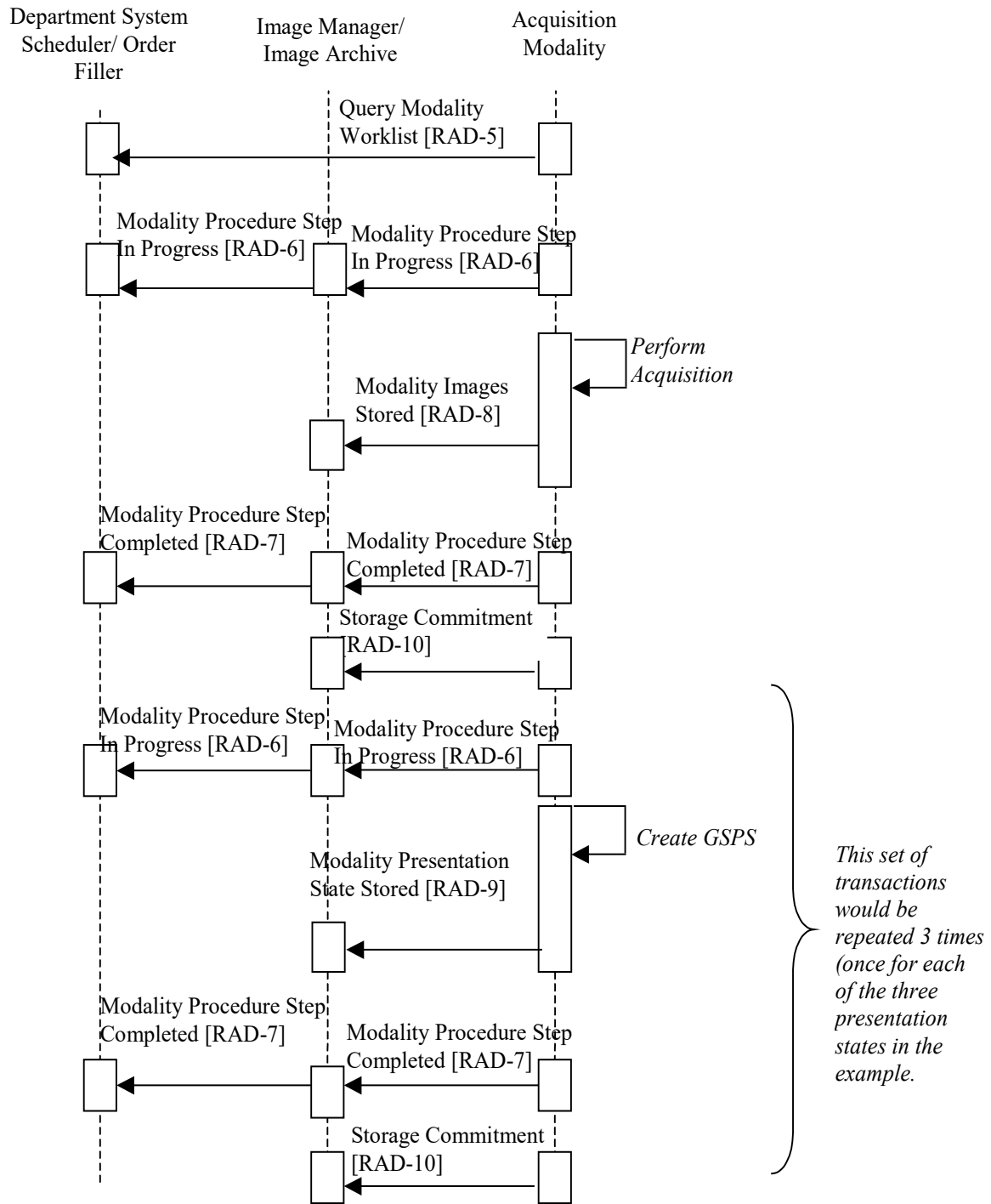

2370

Figure 6.3-1: Presentation of Grouped Procedures Process Flow

7 Access to Radiology Information (ARI)

2375 The *Access to Radiology Information Integration Profile* specifies a number of query transactions providing access to radiology information, including images and related reports, in a DICOM format as they were acquired or created. Such access is useful both to the radiology department and to other departments such as pathology, surgery and oncology. Non-radiology information (such as lab reports) may also be accessed if made available in DICOM format.

7.1 Actors/Transactions

2380 Figure 7.1-1 diagrams the actors involved with this profile and the transactions between actors. The italicized transactions represent a “generic” set of query/ retrieve transactions. The specific transactions required are dependent on which specific content profile(s) are supported by the Image Display and Image Manager/ Image Archive Actors.

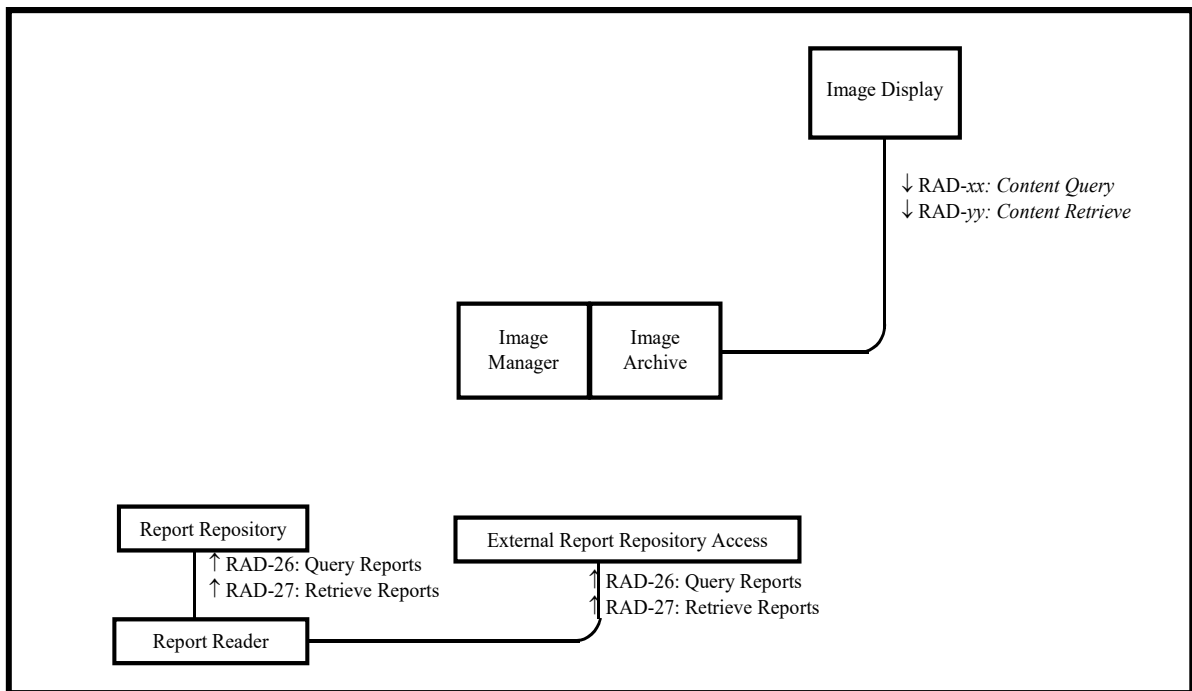

2385

Figure 7.1-1: Access to Radiology Information Diagram

2390 Table 7.1-1 lists the transactions for each actor directly involved in the Access to Radiology Information Integration Profile. In order to claim support of this Integration Profile, an implementation must perform the required transactions (labeled “R”). A complete list of options defined by this Integration Profile and that implementations may choose to support is listed in Section 7.2.

Table 7.1-1: Access to Radiology Information - Actors and Transactions

Actors	Transactions	Optionality	TF Reference
Report Reader	Query Reports [RAD-26]	R	RAD TF-2: 4.26
	Retrieve Reports [RAD-27]	R	RAD TF-2: 4.27
Report Repository	Query Reports [RAD-26]	R	RAD TF-2: 4.26
	Retrieve Reports [RAD-27]	R	RAD TF-2: 4.27
External Report Repository Access	Query Reports [RAD-26]	R	RAD TF-2: 4.26
	Retrieve Reports [RAD-27]	R	RAD TF-2: 4.27
Image Display	Required transactions depend on the Content Profiles supported		
Image Manager/ Image Archive	Required transactions depend on the Content Profiles supported		

2395 Note: Refer to Table 2-1 for other profiles that may be pre-requisites for this profile.

2400 The Image Display and Image Manager/ Archive Actors are required to support the Query/Retrieve transactions for each dependent Content Profile they support. They must support at least one Content Profile, for example the Mammography Image Profile, the NM Image Profile and others.

7.2 Access to Radiology Information Integration Profile Options

Options that may be selected for this Integration Profile are listed in the Table 7.2-1 along with the Actors to which they apply. Dependencies between options when applicable are specified in notes.

2405 **Table 7.2-1: Access to Radiology Information - Actors and Options**

Actor	Options	TF Reference
Image Display	Multiple Sources	RAD TF-1: 7.3.1
Image Manager/ Image Archive	<i>No options defined</i>	
Report Reader	Multiple Sources	RAD TF-1: 7.3.1
Report Repository	<i>No options defined</i>	
External Report Repository Access	<i>No options defined</i>	-

7.3 Multiple Sources Option

This option requires Image Displays and Report Readers to support query and retrieve from multiple information sources in order for a user to gain access to distributed radiology information.

2410 Image Displays, in particular, are typically closely associated with, and draw information from, a single Image Manager/Image Archive. An Image Display that implements this option supports a user that desires to view information consolidated from multiple sources (e.g., ultrasound mini-PACS, cardiology PACS, and radiology PACS).

2415 Querying multiple sources also provides an opportunity for an Image Display to access objects stored in a “legacy” archive that has been replaced by, and is possibly having its information migrated to, a new Image Manager/Image Archive.

7.3.1 Requirements for the Multiple Sources Option

In order to claim support for this profile option, an Image Display shall be able to query and retrieve from multiple Image Manager/Image Archives.

2420 In order to claim support for this profile option, a Report Reader shall be able to query and retrieve from multiple Report Repositories.

There is no requirement as to whether the multiple queries or retrieves are done concurrently or sequentially.

2425 Image Displays and Report Readers shall have the ability to be configured to access multiple Image Manager/Image Archives and Report Repositories (respectively).

2430 Image Managers and Report Managers shall also support the Patient Information Reconciliation integration profile in order to ensure that the information gathered from them is as accurate as possible. Since having actors in different ADT (patient identifier) domains could result in unpredictable query results, this option assumes that all actors are members of the same ADT domain (i.e., it can be assumed that a given patient identifier uniquely refers to a single patient).

An Image Display or Report Reader supporting this profile option may be configured to initially query only its local information source; however, it shall be possible to query multiple sources with a single user request.

2435 When an Image Display and Report Reader are combined, a single user request shall suffice to trigger a query of multiple sources for both images (and anything else stored in an Image Manager/Image Archive) and reports.

If communication with an information source fails, an Image Display or Report Reader shall provide the information it received from the other sources. In addition, the Image Display and Report Reader shall inform the user that they are viewing potentially incomplete results.

2440 When an Image Display or Report Reader performs a study-level or series-level query to multiple sources and finds the study/series referenced in multiple places, the study/series is either duplicated or the study/series is split across the systems. When the user requests a retrieval of the study/series an Image Display and Report Reader shall collate the information, determine if the

2445 information is actually duplicated or split, and present to the user a consolidated view of results. The consolidated view of results may be shown and updated either as responses are received or when the final response has been received from the last responding information source.

A participating Image Display or Report Reader shall manage duplicate instances in a manner that avoids redundant retrieval.

2450

8 Key Image Note (KIN)

2455 The *Key Image Note Integration Profile* specifies transactions that allow a user to mark one or more images in a study as significant by attaching to them a note managed together with the study. This note includes a title stating the purpose of marking the images and, optionally, a user comment field. Physicians may attach Key Image Notes to images for a variety of purposes: referring physician access, teaching files selection, consultation with other departments, and image quality issues, etc.

2460 It should be noted that while Key Image Notes meet the definition of Evidence Documents, they are a special case that is dealt with separately in this Profile for historical reasons. Refer to the Evidence Documents Profile (Section 14) for a description of general evidence document handling.

2465 The process of creating and using Key Image Notes can be managed by worklists that provide patient/ procedure details and by performed procedure steps that report status information (e.g., see Integration Profiles on Scheduled Workflow, Post-Processing Workflow, Reporting Workflow).

8.1 Actors/Transactions

Figure 8.1-1 diagrams the actors involved with this profile and the transactions between actors.

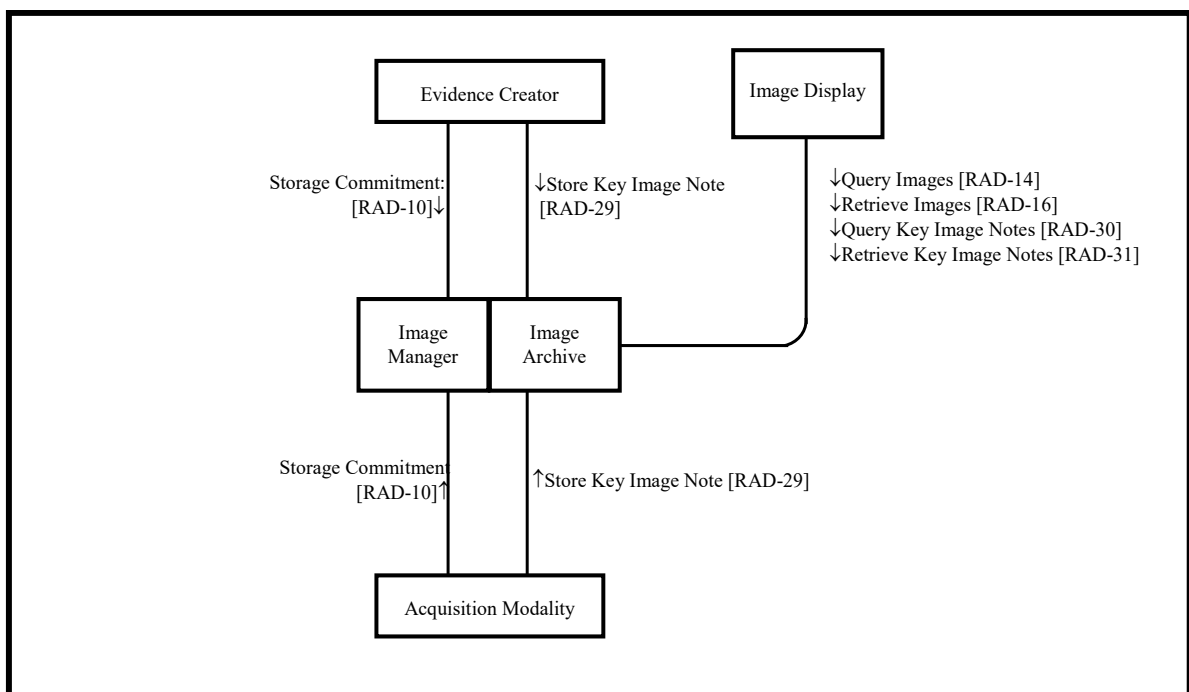

2470

Figure 8.1-1: Key Image Note Diagram

2475

Table 8.1-1 lists the transactions for each actor directly involved in the Key Image Notes Integration Profile. In order to claim support of this Integration Profile, an implementation must perform the required transactions (labeled “R”). Transactions labeled “O” are optional. A complete list of options defined by this Integration Profile and that implementations may choose to support is listed in Section 8.2.

Table 8.1-1: Key Image Note Integration Profile - Actors and Transactions

Actors	Transactions	Optionality	TF Reference
Acquisition Modality	Storage Commitment [RAD-10]	R	RAD TF-2: 4.10
	Key Image Note Stored [RAD-29]	R	RAD TF-2: 4.29
Evidence Creator	Storage Commitment [RAD-10]	R	RAD TF-2: 4.10
	Key Image Note Stored [RAD-29]	R	RAD TF-2: 4.29
Image Manager/ Image Archive Image Archive	Storage Commitment [RAD-10]	R	RAD TF-2: 4.10
	Query Images [RAD-14]	R	RAD TF-2: 4.14
	Retrieve Images [RAD-16]	R	RAD TF-2: 4.16
	Key Image Note Stored [RAD-29]	R	RAD TF-2: 4.29
	Query Key Image Notes [RAD-30]	R	RAD TF-2: 4.30
	Retrieve Key Image Notes [RAD-31]	R	RAD TF-2: 4.31
Image Display	Query Images [RAD-14]	R	RAD TF-2: 4.14
	Retrieve Images [RAD-16]	R	RAD TF-2: 4.16
	Query Key Image Notes [RAD-30]	R	RAD TF-2: 4.30
	Retrieve Key Image Note [RAD-31]	R	RAD TF-2: 4.31

Refer to Table 2-1 for other profiles that may be pre-requisites for this profile.

8.2 Key Image Notes Integration Profile Options

2480

Options that may be selected for this Integration Profile are listed in the Table 8.2-1 along with the Actors to which they apply. Dependencies between options when applicable are specified in notes.

Table 8.2-1: Key Image Notes - Actors and Options

Actor	Options	TF Reference
Acquisition Modality	<i>No options defined</i>	-
Evidence Creator	<i>No options defined</i>	-
Image Manager/ Image Archive	<i>No options defined</i>	-
Image Display	<i>No options defined</i>	-

8.3 Key Image Note Pattern

2485 The Key Image Note allows a user to mark one or more images in a study as significant by
 attaching to them one or more notes managed together with the study. Each note includes a title
 stating the purpose of marking the images and a user comment. Physicians may attach Key
 Image Notes to images for a variety of purposes: referring physician access, teaching files
 2490 7010 (Key Object Selection Document Title) in DICOM PS3.16.

A single Key Image Note may reference several images within a study. Multiple Key Image
 Notes may reference the same image.

2495 When a Key Image Note refers to an image, it may also include a reference to a specific
 Presentation State for the image thus ensuring that the Key Image Note includes significant
 information about the image presentation state (window width/window level, flip, zoom, rotate,
 graphical and textual annotations as defined in the Consistent Presentation of Images Integration
 Profile). This information may be used by the Image Display that supports both the Key Image
 Notes and Consistent Presentation of Images Integration Profiles.

2500 The content pattern of a Key Image Note is shown in Figure 8-2-1 and shall use the DICOM Key
 Object Selection Document SOP Class definition. The marked images of a study are those
 referenced by a Key Object Selection Document that belong to the same study as the Key Object
 Selection Document.

2505 IHE does not require Evidence Creator Actors producing Key Image Notes to support the ability
 to reference images outside of the study. However, if they chose to do so, the inclusion of the
 Identical Documents Sequence is required per the DICOM Standard.

2510 IHE requires Image Display Actors receiving Key Image Notes to display the fact that images
 referenced by the Key Object Selection Document belonging to the same study are flagged. It is
 beyond the scope of IHE to specify the means used to show this fact. Although Image Display
 recipients of Key Image Notes are required, per the DICOM Standard, to accept the Key Object
 Selection Documents with references outside the study, they are not required but may choose to
 support retrieval and display of the images from other studies outside of the one to which the
 Key Image Note belongs.

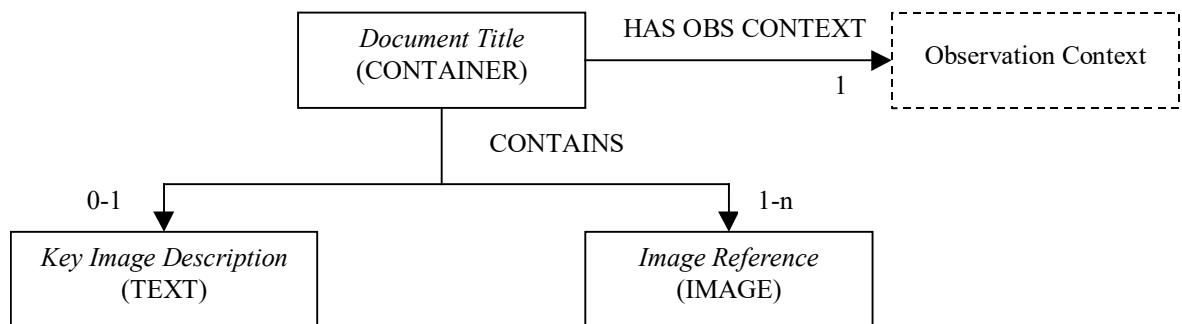

Figure 8.3-1: Key Image Note Pattern

2515 **9 Simple Image and Numeric Report (SINR)**

2520 The *Simple Image and Numeric Report Integration Profile* facilitates the growing use of digital dictation, voice recognition, and specialized reporting packages, by separating the functions of reporting into discrete s for creation, management, storage and viewing. Separating these functions while defining transactions to exchange the reports between them enables a vendor to include one or more of these functions in an actual system.

2525 Reports exchanged have a simple structure attractive to many imaging departments: a title, an observation context, and one or more sections, each with a heading, observation context, text, image references, and optionally coded measurements. Some elements can also be coded to facilitate computer searches. Such reports can be input to the formal diagnostic report, thus avoiding re-entry of information.

The process of creating imaging reports can be managed by worklists that provide patient/procedure details and by performed procedure steps that report status information (e.g., see the Reporting Workflow Integration Profile).

9.1 Actors/Transactions

2530 Figure 9.1-1 diagrams the actors involved with this profile and the transactions between actors.

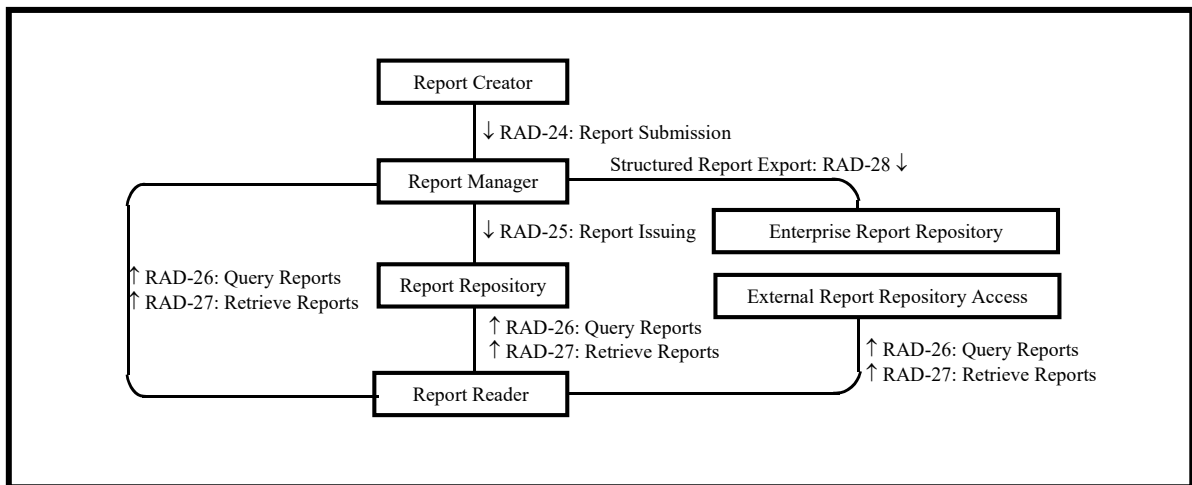

Figure 9.1-1: Simple Image and Numeric Report Diagram

2535

2540

Table 9.1-1 lists the transactions for each actor directly involved in the Simple Image and Numeric Report Integration Profile. In order to claim support of this Integration Profile, an implementation must perform the required transactions (labeled “R”). Transactions labeled “O” are optional. A complete list of options defined by this Integration Profile and that implementations may choose to support is listed in Section 9.2.

Table 9.1-1: Simple Image and Numeric Report - Actors and Transactions

Actors	Transactions	Optionality	TF Reference
Report Creator	Report Submission [RAD-24]	R	RAD TF-2: 4.24
Report Manager	Report Submission [RAD-24]	R	RAD TF-2: 4.24
	Report Issuing [RAD-25]	R	RAD TF-2: 4.25
	Query Reports [RAD-26]	R	RAD TF-2: 4.26
	Retrieve Reports [RAD-27]	R	RAD TF-2: 4.27
	Structured Report Export [RAD-28]	O	RAD TF-2: 4.28
Report Reader	Query Reports [RAD-26]	R	RAD TF-2: 4.26
	Retrieve Reports [RAD-27]	R	RAD TF-2: 4.27
Report Repository	Report Issuing [RAD-25]	R	RAD TF-2: 4.25
	Query Reports [RAD-26]	R	RAD TF-2: 4.26
	Retrieve Reports [RAD-27]	R	RAD TF-2: 4.27
External Report Repository Access	Query Reports [RAD-26]	R	RAD TF-2: 4.26
	Retrieve Reports [RAD-27]	R	RAD TF-2: 4.27
Enterprise Report Repository	Structured Report Export [RAD-28]	R	RAD TF-2: 4.28

Refer to Table 2-1 for other profiles that may be pre-requisites for this profile.

9.2 Simple Image and Numeric Report Integration Profile Options

2545

Options that may be selected for this Integration Profile are listed in the Table 9.2-1 along with the actors to which they apply. Dependencies between options when applicable are specified in notes.

Table 9.2-1: Simple Image and Numeric Report - Actors and Options

Actor	Options	TF Reference
Enterprise Report Repository	<i>No options defined</i>	-
External Report Repository Access	<i>No options defined</i>	-
Report Creator	Enhanced SR	RAD TF-2: 4.24.4.1.2
Report Manager	<i>No options defined</i>	-
Report Reader	Enhanced SR	RAD TF-2: 4.27.4.2.2
Report Repository	<i>No options defined</i>	-

- 2550 The Report Creator, Report Manager and Report Repository will likely support a variety of DICOM SOP Classes. It is expected that this level of optionality will be documented by a reference in the IHE Integration Statement (see Appendix D).

9.3 Diagnostic Report Process Flow

- 2555 This section describes the typical process flow related to diagnostic reporting. The transactions covered are [RAD-24] through [RAD-27].

In the initial stage of diagnostic reporting, a reading physician records the diagnosis by generating a draft DICOM Structured Report object, which is submitted to the Report Manager. Once a report is sent to the Report Manager, the Report Creator relinquishes control of the report to the Report Manager.

- 2560 There are other documents which are sometimes referred to as “reports” and may be encoded using DICOM SR (for example, procedure reports, CAD results and echocardiography measurement reports) however such documents do not follow the same kind of verification and distribution process described in this profile. These other documents serve different purposes and are instead addressed in the Evidence Documents Profile.

- 2565 Reports are processed and modified by the Report Manager. This involves adding and changing report data as well as verifying draft reports. In all cases, any change in the report content by the Report Manager leads to the creation of a new DICOM Structured Report object. At any time, the Report Manager can transmit reports to the Report Repository for external access, but at a minimum the final report must be sent to the Report Repository. A Report Creator can effectively amend a report by submitting a new SR SOP Instance.

The Report Repository provides permanent storage of DICOM Structured Reports. It also allows reports to be queried and retrieved throughout the enterprise by Report Readers. A Report Reader provides a user interface to view DICOM Structured Reports that it retrieves from the Report Repository or External Report Repository Access.

- 2575 The External Report Repository Access is a gateway to obtain other enterprise department reports, such as Laboratory and Pathology, from within the Imaging department. DICOM Structured Reports are queried and retrieved by a Report Reader from the External Report Repository Access.

The Enterprise Report Repository receives diagnostic reports in HL7 format.

- 2580 The Simple Image Report and Simple Image and Numeric Reports are required minimally to have the functionality defined in template TID 2000. Creators may introduce increased complexity as long as it conforms to the SOP class. The templates referenced in the Technical Framework are included in DICOM Part 16.

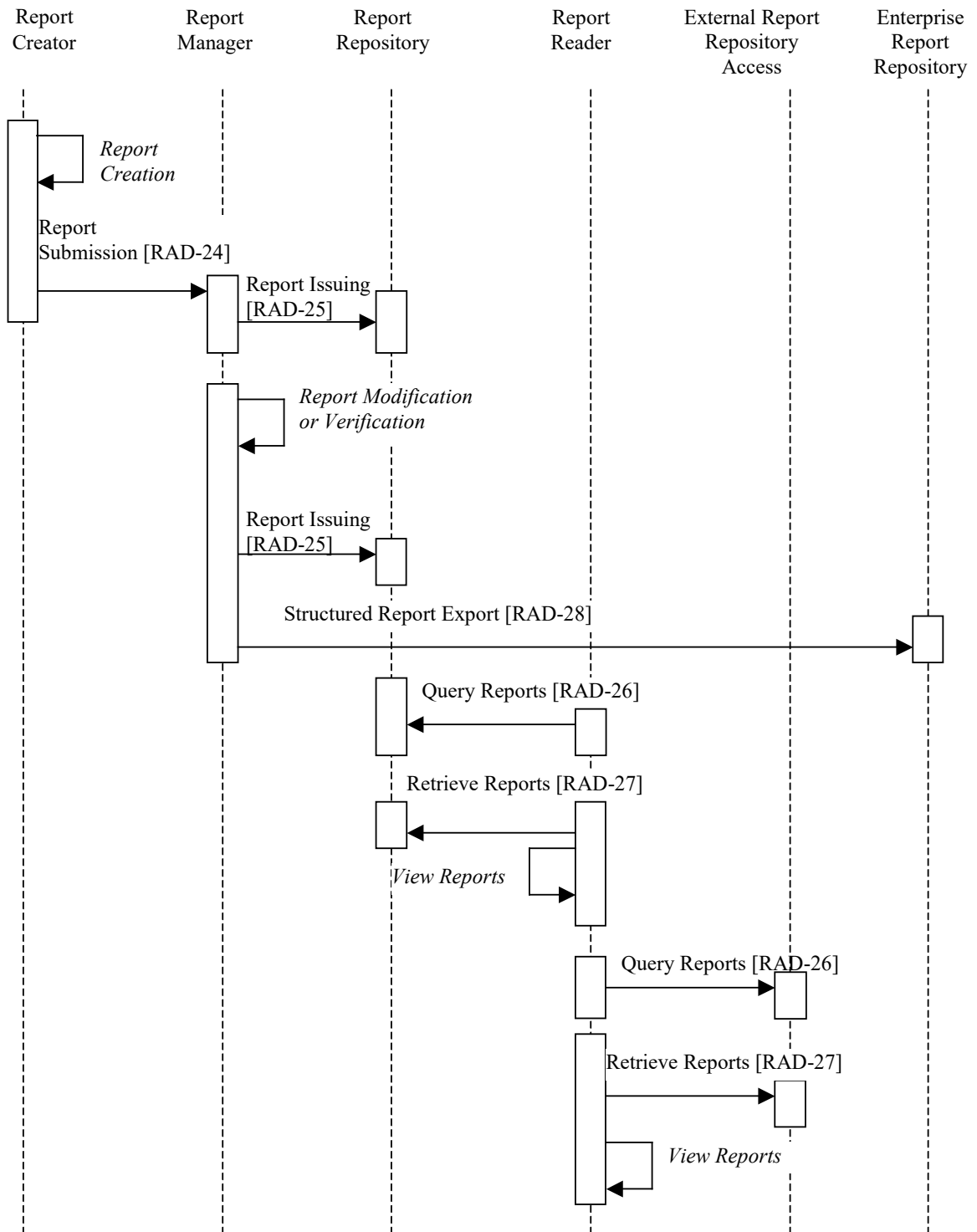

2585

Figure 9.3-1: Diagnostic Reporting Process Flow

9.4 Diagnostic Reporting Use Cases

2590 DICOM Structured Reports offer the capability to encode arbitrarily structured diagnostic report data. The Radiology Technical Framework stipulates that the reporting actors need to support several use cases and their specific content patterns, which are detailed in the following sections.

The diagrams in the following sections define the report content pattern and utilize the following conventions:

- Each rectangle is a single Content Item.
- 2595 • Italic text in a rectangle denotes a generic grouping of Concept Names to be used for the Content Item. These must be configurable in the reporting actors.
- Uppercase text in a rectangle denotes the Content Item Value Type.
- Text following the Content Item Value Type specifies the possible Content Item Value(s), if known (only used for Observation Context).
- Text on lines defines the relationship between Content Items.
- 2600 • Numbers on lines define the cardinality of descendent Content Items.

9.4.1 Simple Image Report

2605 The Simple Image Report allows documents with multiple sections (with headings) containing report text and references to relevant images. Some text items of these documents may also be related to specific images. This allows a reading physician to identify one or more images from which their conclusions were inferred. This content pattern is shown in Figure 9.4-1 and shall use the DICOM Basic Text SR Information Object Definition and Basic Image Diagnostic Report Template (TID 2000 in DICOM PS3.16). Note that TID 2000 has other requirements not shown in the diagram.

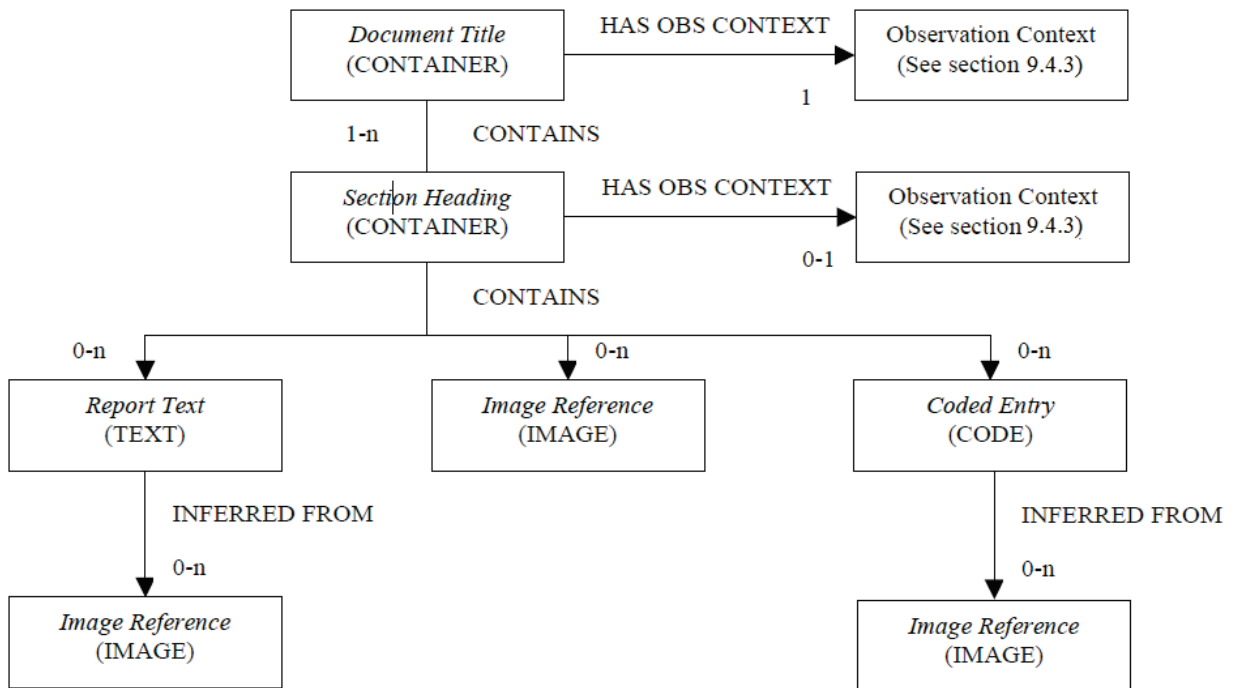

2610

Figure 9.4-1: Simple Image Report Pattern

9.4.2 Simple Image and Numeric Report

2615

The Simple Image and Numeric Report is similar to the Simple Image Report described in Section 9.3.1 but allows the addition of numeric values. This enables a diagnosis to include measurements and other numeric values. Like the Simple Image Report, particular text values can be encoded to signify that they are inferred from specific images or numeric values. This content pattern is shown in Figure 9.4-2 and shall use the DICOM Enhanced SR Information Object Definition and Basic Image Diagnostic Report Template (TID 2000 in DICOM PS3.16). Note that TID 2000 has other requirements not shown in the diagram.

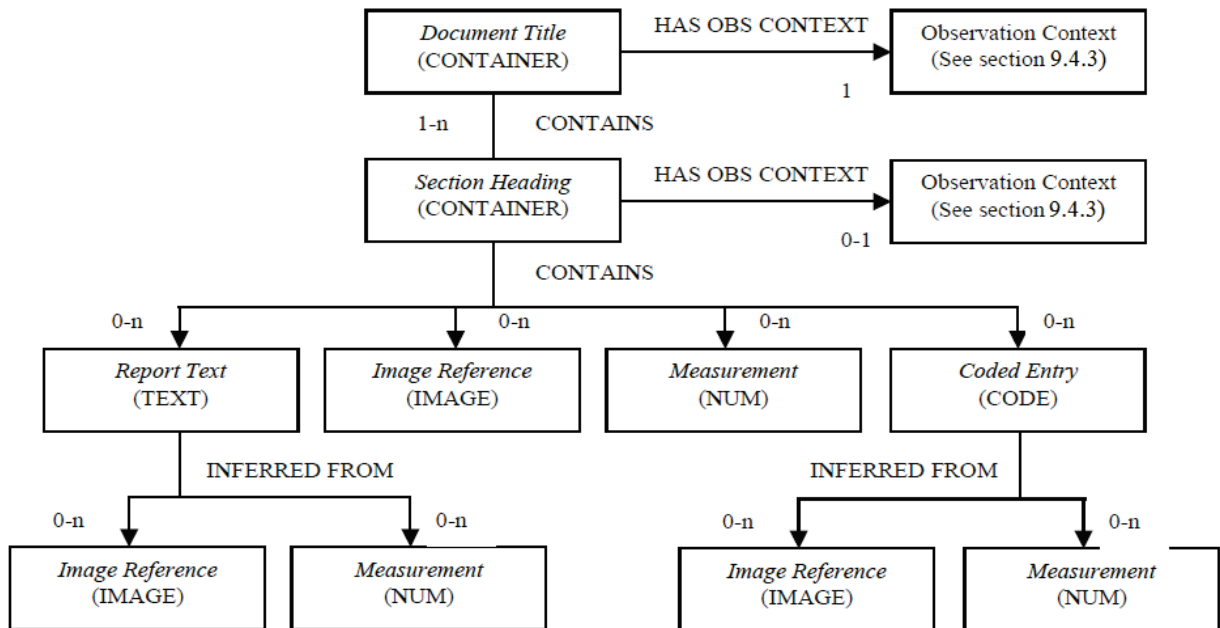

2620

Figure 9.4-2: Simple Image and Numeric Report Pattern

9.4.3 Observation Context

2625 Encoding of the Observation Context for Simple Image Report and Simple Image and Numeric Report shall follow the definition of corresponding standardized template TID 1001. The template is contained in DICOM PS3.16: DICOM Content Mapping Resource (DCMR).

2630 Observation context content items may be descended from the root content item, and may be superseded by subsequent observation contexts at the section level. Therefore, the observation context may change throughout the report. This capability allows one report to include, for example, observations on a mother and fetus, observations by multiple observers, or observations from multiple studies.

10 Basic Security (SEC) - DEPRECATED

This profile has been superseded by the Radiology Audit Trail Option in ITI-Audit Trail and Node Authentication Profile (see RAD TF-3: 5.1 for a detailed description of the Radiology Audit Trail Option).

2635

11 Charge Posting (CHG)

2640 The *Charge Posting Integration Profile* specifies information exchange from the Department System Scheduler/Order Filler to the Charge Processor about charges associated with particular procedures, as well as communication about patient demographics, accounts, insurance, and guarantors between ADT Patient Registration and Charge Processor. The Charge Posted Transaction contains some information to generate a claim. Currently, these interfaces contain fixed field formatted or HL7-like data. The goal of including this in the Radiology Technical Framework is to standardize interface between clinical systems and the Charge Processors.

2645 Additionally, the Charge Posted Transaction reduces the need of the billing system to have knowledge of the radiology internals. The result is that the Charge Processor will receive more complete, timely and accurate data.

2650 The Department System Scheduler/Order Filler indicates to the Charge Processor that procedures are available for Technical and/or Professional billing. The Charge Posted transaction may occur at various times in the workflow. Regulations and site operating procedures determine when a procedure is eligible for Charge Posting. Often, the events are different for technical and professional charges.

Technical charges are typically eligible at procedure completion.

Professional charges are typically eligible at result verification.

2655 Events that may trigger charges are Procedure Ordered, Procedure Scheduled, Procedure Completed, Result Dictated, Result Transcribed, and Result Verified.

11.1 Actors/Transactions

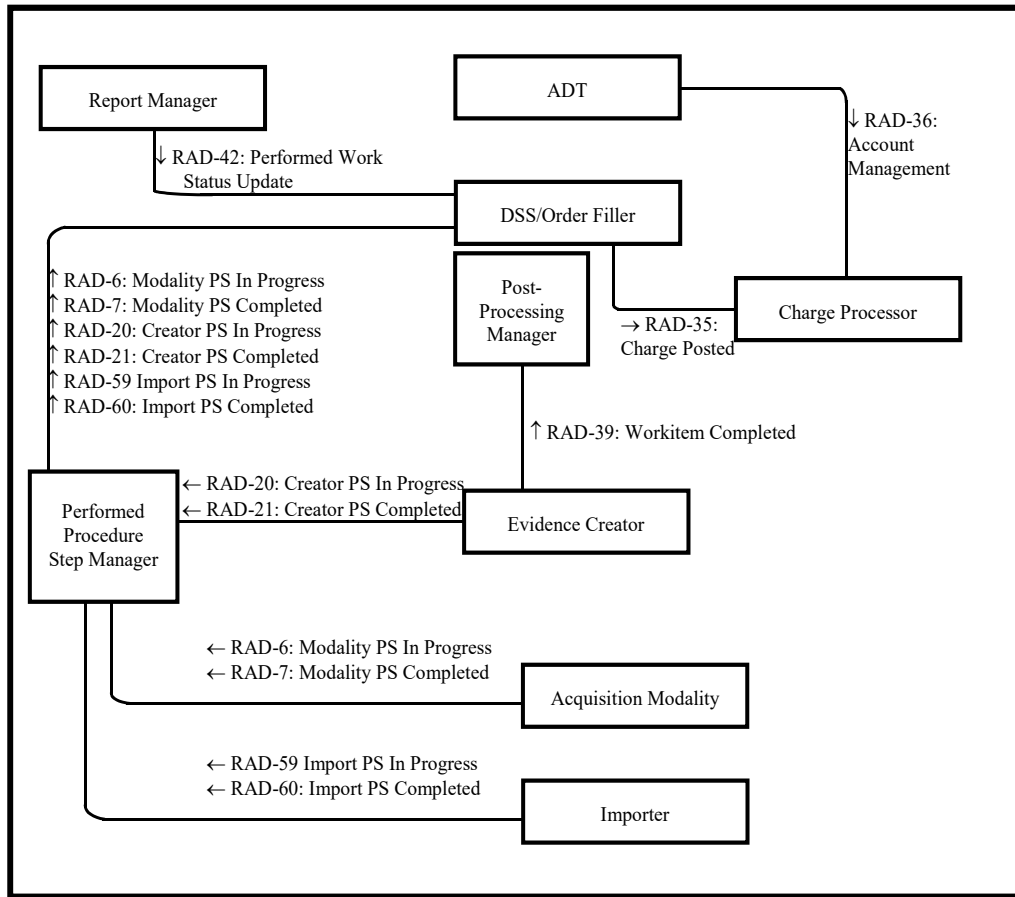

2660

Figure 11.1-1: Charge Posting Transaction Diagram

Table 11.1-1 lists the transactions for each actor directly involved in the Charge Posted Profile. In order to claim support of this Integration Profile, an implementation must perform the required transactions (labeled “R”). Transactions labeled “O” are optional. A complete list of options defined by this Integration Profile and that implementations may choose to support is listed in Section 11.2.

2665

Table 11.1-1: Charge Posting – Actors and Transactions

Actors	Transactions	Optionality	TF Reference
ADT Patient Registration	Account Management [RAD-36]	R	RAD TF-3: 4.36
Department System Scheduler/Order Filler/Performed Procedure Step Manager (note 3)	Charge Posted [RAD-35] (note 5)	R	RAD TF-3: 4.35
	Modality Procedure Step In Progress [RAD-6]	R	RAD TF-2: 4.6
	Modality Procedure Step Completed [RAD-7] (note 2)	R	RAD TF-2: 4.7

Actors	Transactions	Optionality	TF Reference
	Creator PS In Progress [RAD-20]	R	RAD TF-2: 4.20
	Creator PS Completed [RAD-21]	R	RAD TF-2: 4.21
	Performed Work Status Update [RAD-42]	R	RAD TF-3: 4.42
	Import Procedure Step In Progress [RAD-59]	R	RAD TF-3: 4.59
	Import Procedure Step Completed [RAD-60] (note 4)	R	RAD TF-3: 4.60
Acquisition Modality	Modality Procedure Step In Progress [RAD-6] (note 1)	R	RAD TF-2: 4.6
	Modality Procedure Step Completed [RAD-7]	R	RAD TF-2: 4.7
Report Manager	Performed Work Status Update [RAD-42]	R	RAD TF-3: 4.42
Evidence Creator	Creator PS In Progress [RAD-20]	R	RAD TF-2: 4.20
	Creator PS Completed [RAD-21]	R	RAD TF-2: 4.21
Post-Processing Manager (note 3)	Workitem Completed [RAD-39]	R	RAD TF-3: 4.39
Charge Processor	Charge Posted [RAD-35] (note 5)	R	RAD TF-3: 4.35
	Account Management [RAD-36]	R	RAD TF-3: 4.36
Importer	Import Procedure Step In Progress [RAD-59]	R	RAD TF-3: 4.59
	Import Procedure Step Completed [RAD-60] (note 4)	R	RAD TF-3: 4.60

Note: Refer to Table 2-1 for other profiles that may be pre-requisites for this profile.

- 2670 Note 1: An Acquisition Modality that claims the Charge Posting Profile shall support the Assisted Protocol Setting Option (see RAD TF-2: 4.6.4.1.2.4.2).
- Note 2: In the transaction, the DSS/Order Filler shall use the Billing and Material Management information supplied by the Acquisition Modality (see RAD TF-2: 4.7.4.1.3.2) or the Importer (see RAD TF-2: 4.7.4.1.3.2 and RAD TF-3: 4.60.4.1.3.2)
- 2675 Note 3: The Post-Processing Manager participates in this profile only if the Post Processing Workflow Integration Profile is one of the pre-requisite profiles supported. In this case, the Post-Processing Manager shall be grouped with the DSS/ Order Filler.
- Note 4: To claim the Charge Posting Profile, the Importer shall support the Billing and Material Management Option (see RAD TF-3: 4.60.4.1.2.3).
- 2680 Note 5: The DSS/Order Filler and Charge Processor shall support the HL7v2.3.1 semantics for [RAD-35]. (See RAD TF-3: 4.35.4.1.2).

11.2 Charge Posting Integration Profile Options

Options that may be selected for this Integration Profile are listed in the Table 11.2-1 along with the Actors to which they apply. Dependencies between options when applicable are specified in notes.

2685

Table 11.2-1: Charge Posting – Actors and Options

Actor	Options	TF Reference
ADT Patient Registration	<i>No options defined</i>	-
Department System Scheduler/ Order Filler	<i>No options defined</i>	-
Acquisition Modality	PPS Exception Management	RAD TF-2: 4.7
	Modality Group Case	RAD TF-2: 4.6
	Billing and Material Management	RAD TF-2: 4.7.1.2.3
Performed Procedure Step Manager	<i>No options defined</i>	-
Evidence Creator (Note 1)	<i>No options defined</i>	-
Report Manager	<i>No options defined</i>	-
Charge Processor	<i>No options defined</i>	-
Importer	Billing and Material Management	RAD TF-3: 4.60.4.1.2.3

Note 1: The Billing and Materials Management Option may in some cases also apply to an Evidence Creator Actor in Charge Posting. However, it is at this time not specified.

11.3 Charge Posting Process Flow

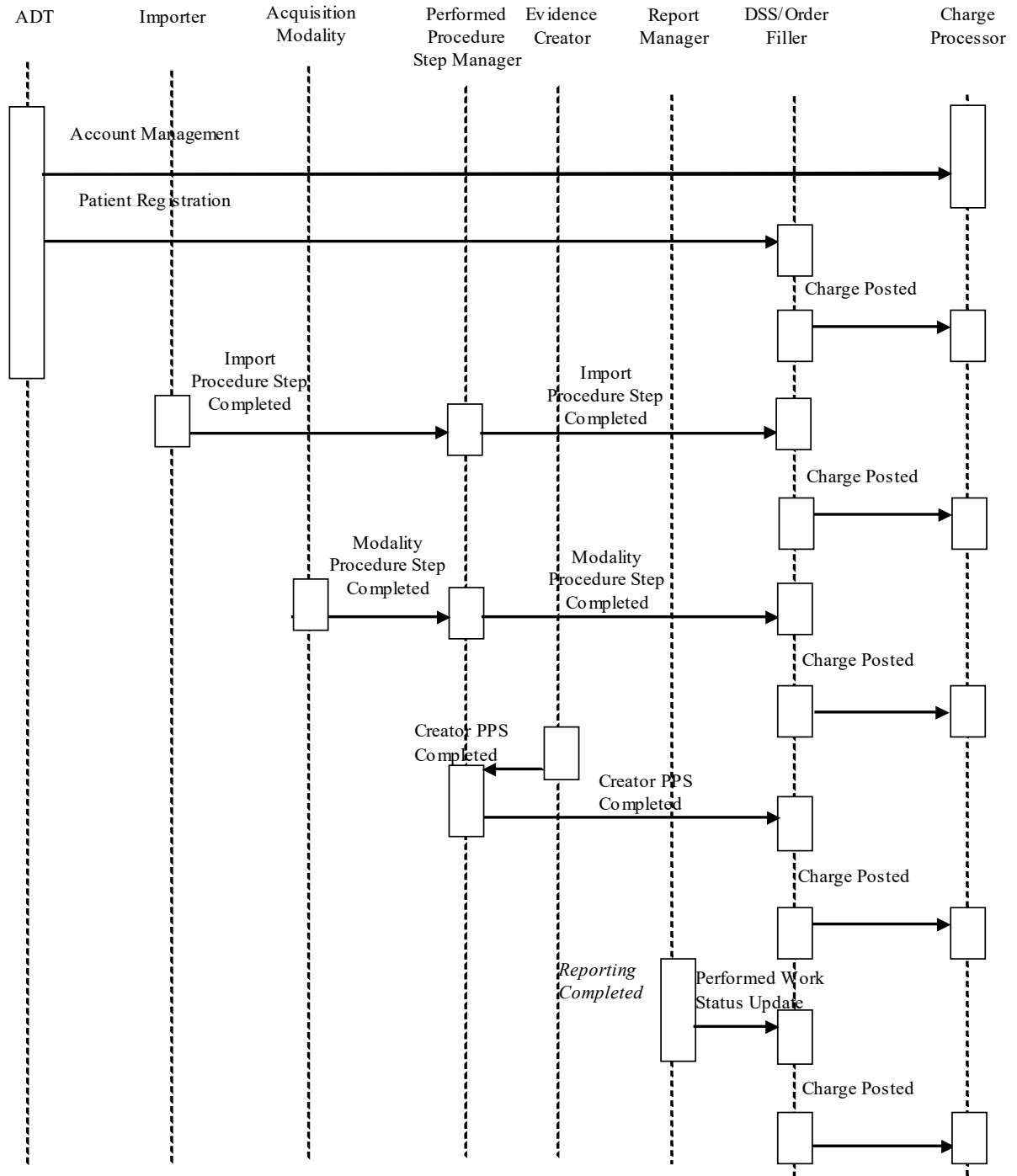

2690

Figure 11.3-1: Charge Posting Process Flow

Events that may trigger a charge posted transaction are Procedure Ordered, Procedure Scheduled, Procedure Completed, Result Dictated, Result Transcribed, and Result Verified.

11.3.1 Use Cases

2695 This section describes the potential use cases relating to the charge posting functionality. It is the responsibility of the Department System Scheduler/Order Filler to ensure that the billing information is sent to the Charge Processor. The Department System Scheduler/Order Filler forwards the data that is required by the Charge Processor to generate the claim.

2700 The Charge Processor shall accept the Charge Posted Transaction information. Interpretation and subsequent billing processes by the Charge Processor are beyond the scope of this profile.

Below are listed the typical use cases:

- A Department System Scheduler/Order Filler makes technical charges available for posting when the modality has completed the procedure.
- A Department System Scheduler/Order Filler makes professional charges available for posting at time of report verification.
- A site makes both technical and professional charges available at time of result verification.
- A site may have a single charge that comprises both the technical and professional components.

2710 11.3.2 Technical Billing

Technical charges are based on the procedure and often include typical materials usage. These are one or more charges that are included in the Charge Posted Transaction. The Charge Posted Transaction message can be sent immediately when the Department System Scheduler/Order Filler receives confirmation that the procedure is completed. Additionally, a site may wish to send information on materials used during a procedure to the Charge Processor for inclusion with the technical charges.

Note that it may be site policy to verify from the Image Manager that the images have been stored. This is dependent on the business rules established for that site.

11.3.3 Professional Billing

2720 Professional charges are based on the reading physician providing the results for the procedure. These are one or more charges that are included in the Charge Posted Transaction. The Professional Billing Charge Posted Transaction can be sent any time after the Department System Scheduler/Order Filler receives confirmation from the Report Manager that the report has been completed and verified. This may be done by grouping the Report Manager with Department System Scheduler.

2725 Note that IHE specifies a non-country specific procedure coding scheme.

The Charge Posted Transaction defines the below sources of information:

- Patient Order Information
 - Scheduling and Requested Procedure
 - 2730 • Scheduling and Scheduled Procedure Step
- Modality Performed Procedure Step
 - Status Information - Completed / Discontinued
 - Protocol Code
 - Consumables
- 2735 • Optionally, additional manual input or processing by the Department System Scheduler/Order Filler

11.4 Data Model for Charge Posting

The data model adopted by the Radiology Technical Framework for the HL7 messages used in the Charge Posting Profile is based on a subset of HL7 v2.3.1 as described in Section 11.3.1.

2740 11.4.1 Model of the Real World

Figure 11.4-1 depicts the model of the real world within scope of the Charge Posting Profile. This model corresponds to the approach suggested in the HL7 standard, in particular:

- Financial data related to the patient are accumulated as properties of accounts. A patient may have more than one active (open) account at a time.
- 2745 • One account may contain financial data pertaining to more than one Visit. A visit, however, cannot span multiple accounts.
- There may be multiple Billable Procedures performed and multiple charges posted as a result of one visit. There may be one charge posted for multiple procedures and one procedure to be charged in multiple charge postings, for example, for Technical and Professional charges.
- 2750 • Requested Procedures may be Billable Procedures. One Requested Procedure may correspond to more than one Billable Procedure.

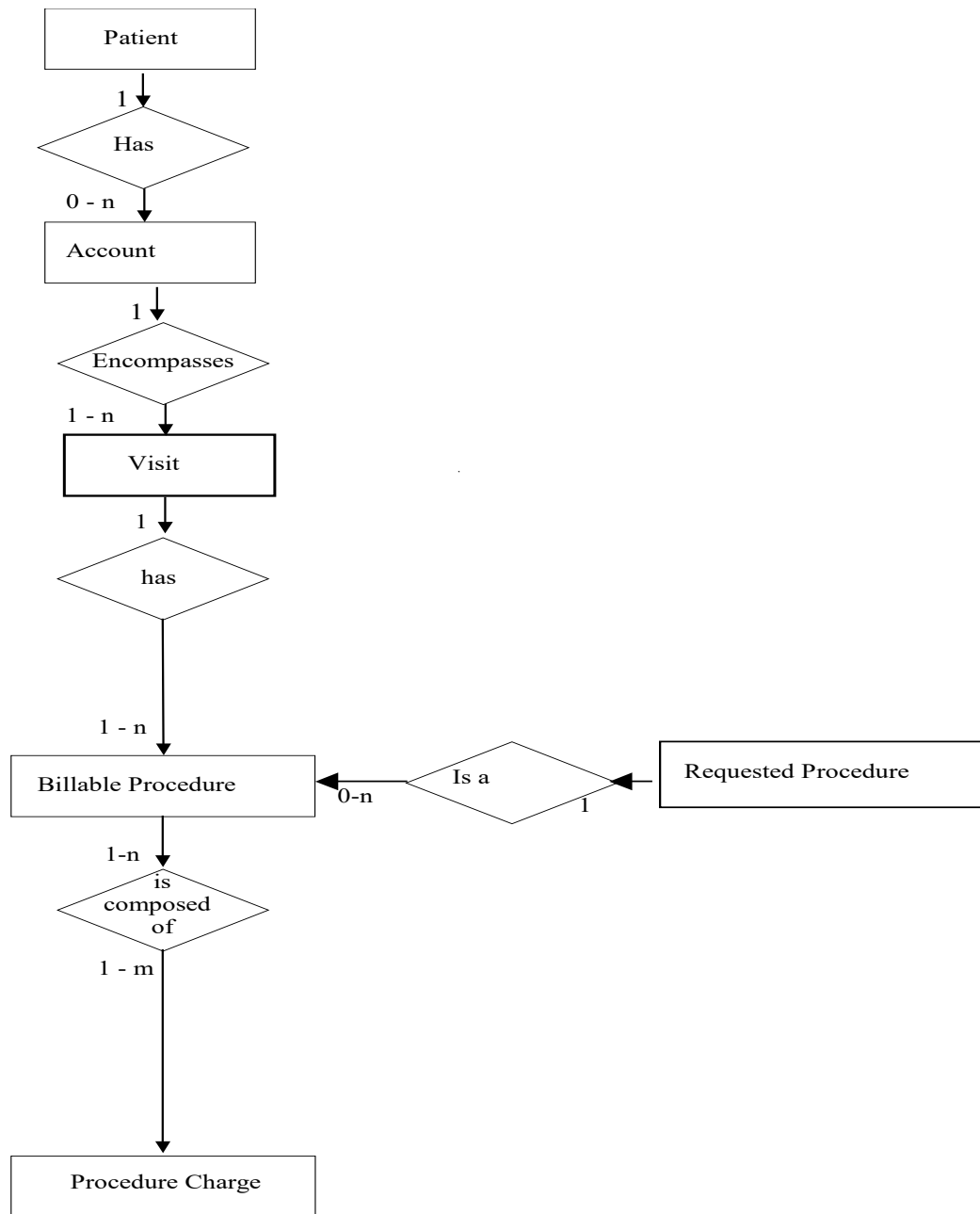

2755

Figure 11.4-1: Model of the Real World for Charge Posting

12 Post-Processing Workflow (PWF)

2760 **IMPORTANT NOTE:** *As of June 2012, IHE introduced a new Trial Implementation Profile: Post-Acquisition Workflow (PAWF). The use cases addressed are largely the same as PWF, but the underlying mechanisms are improved. The PWF Profile documented in this section has been deprecated by the Radiology Domain and is now replaced by PAWF. When the PAWF Profile becomes Final Text, the contents of this section will be removed. In the interim, new implementations should be based on PAWF, found at http://www.ihe.net/Technical_Frameworks/#radiology*

2765 The Post-Processing Workflow Integration Profile addresses the need to schedule and track the status of the typical post-processing workflow steps, such as Computer Aided Detection or Image Processing. Worklists for each of these tasks are generated and can be queried, workitems can be selected and the resulting status returned from the system performing the work to the system managing the work. Typically, the workitems will involve the creation of objects such as
2770 images and evidence documents. The created images and evidence documents contain the necessary references for maintaining continuity of order information.

The Post-Processing Workflow Integration Profile is a continuation of the Scheduled Workflow Integration Profile.

12.1 Actors/Transactions

2775 Figure 12.1-1 shows the actors directly involved in the Post-Processing Workflow Integration Profile and the relevant transactions between them. The italicized transactions represent a “generic” set of query/ retrieve transactions. The specific transactions required are dependent on which specific content profile(s) are supported by the Image Display and Image Manager/ Image Archive Actors.

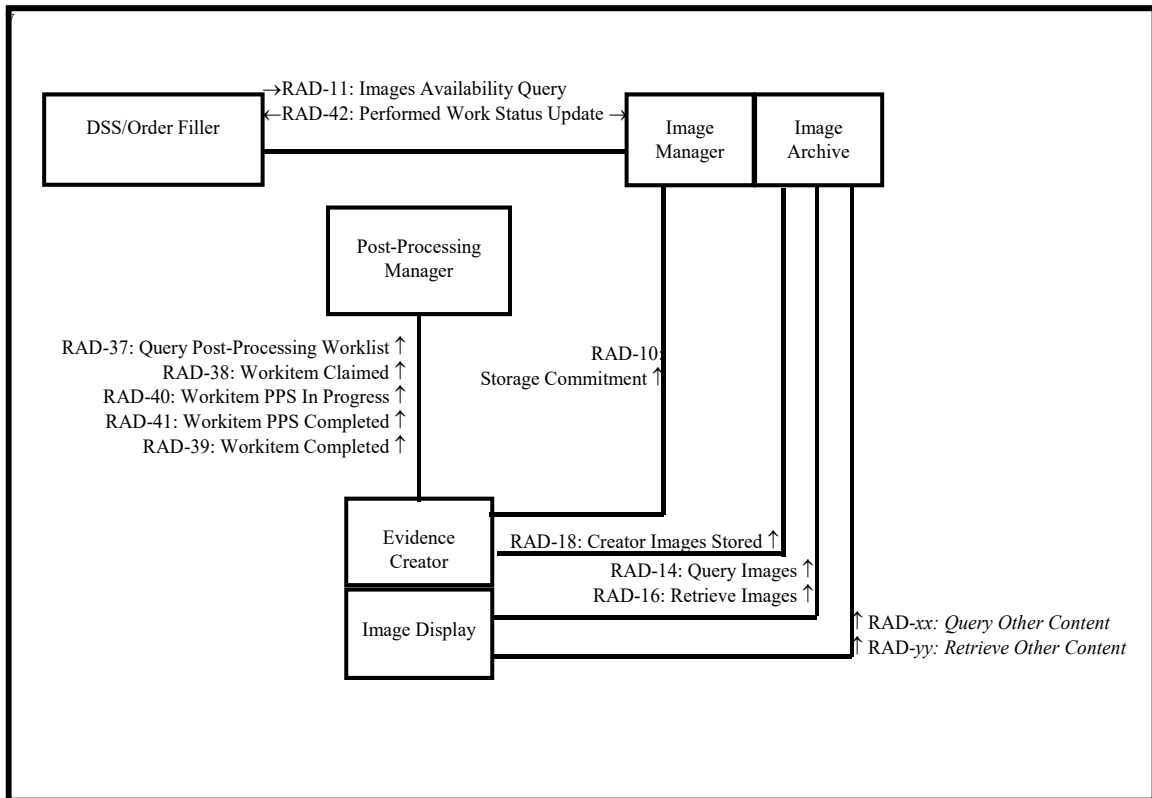

2780

Figure 12.1-1: Post-Processing Workflow Actor Diagram

Table 12.1-1 lists the transactions for each actor directly involved in the Post-Processing Integration Profile. In order to claim support of this Integration Profile, an implementation must perform the required transactions (labeled “R”). Transactions labeled “O” are optional. A complete list of options defined by this Integration Profile and that implementations may choose to support is listed in Section 12.2.

2785

Table 12.1-1: Post-Processing Integration Profile - Actors and Transactions

Actors	Transactions	Optionality	TF Reference
Department System Scheduler/ Order Filler	Images Availability Query [RAD-11]	R	RAD TF-2: 4.11
	Performed Work Status Update (Send) [RAD-42]	R	RAD TF-3: 4.42
Image Manager/ Image Archive	Images Availability Query [RAD-11]	R	RAD TF-2: 4.11
	Query Images [RAD-14]	O	RAD TF-2: 4.14
	Retrieve Images [RAD-16]	O	RAD TF-2: 4.16
	Creator Images Stored [RAD-18]	O	RAD TF-2: 4.18
	Storage Commitment [RAD-10]	O	RAD TF-2: 4.10
	Performed Work Status Update (Send) [RAD-42]	R	RAD TF-3: 4.42
	Query Images [RAD-14]	O	RAD TF-2: 4.14

Actors	Transactions	Optionality	TF Reference
Evidence Creator/Image Display	Retrieve Images [RAD-16]	O	RAD TF-2: 4.16
	Creator Images Stored [RAD-18]	O	RAD TF-2: 4.18
	Storage Commitment [RAD-10]	O	RAD TF-2: 4.10
	Query Post-Processing Worklist [RAD-37]	R	RAD TF-3: 4.37
	Workitem Claimed [RAD-38]	R	RAD TF-3: 4.38
	Workitem PPS In Progress [RAD-40]	R	RAD TF-3: 4.40
	Workitem PPS Completed [RAD-41]	R	RAD TF-3: 4.41
	Workitem Completed [RAD-39]	R	RAD TF-3: 4.39
Post-Processing Manager	Query Post-Processing Worklist [RAD-37]	R	RAD TF-3: 4.37
	Workitem Claimed [RAD-38]	R	RAD TF-3: 4.38
	Workitem PPS In Progress [RAD-40]	R	RAD TF-3: 4.40
	Workitem PPS Completed [RAD-41]	R	RAD TF-3: 4.41
	Workitem Completed [RAD-39]	R	RAD TF-3: 4.39

Note: Refer to Table 2-1 for other profiles that may be pre-requisites for this profile.

2790 Table 12.1-1 represents the case where the Evidence Creator and Image Display are performing post-processing on image objects and therefore the relevant storage, query, retrieve and storage commit transactions are listed.

2795 The Evidence Creator, Image Display and Image Manager Actors may also support the Consistent Presentation of Images or Key Image Note Profiles. In that case, the Evidence Creator is expected to create GSPS and Key Image Note objects as part of its scheduled workitems. The Image Display and Image Manager Actors would be expected to store, commit, query, retrieve and display those objects as described in the relevant profiles.

2800 The scenarios shown in the following flow diagrams happen not to include GSPS or Key Image Note related transactions. Those transactions would typically be sequenced in the same location as the corresponding image object related transactions.

12.2 Post-Processing Workflow Integration Profile Options

Options that may be selected for this Integration Profile are listed in the table below along with the Actors to which they apply.

Table 12.2-1: Post-Processing Integration Profile – Actors and Options

Actors	Option	TF Reference
Department System Scheduler/Order Filler	<i>No options defined</i>	-
Image Manager/Image Archive	<i>No options defined</i>	-
Image Display	<i>No options defined</i>	-
Evidence Creator/Image Display	<i>No options defined</i>	-

Actors	Option	TF Reference
Post-Processing Manager	<i>No options defined</i>	-

2805 12.3 Implementation Issues

12.3.1 Actor Grouping Clarification

This profile is designed with the following implementation scenarios in mind:

Scenario 1:

2810 The Post-Processing Manager is grouped with the Image Manager in System A. The DSS in System B needs status information. In this case:

System A claims support of the Post-Processing Workflow Profile as the Post-Processing Manager and Image Manager Actors.

System B claims support of the Scheduled Workflow Profile as the DSS Actor and implements the optional Performed Work Status Update transaction.

2815 Scenario 2:

The Post-Processing Manager is grouped with the DSS in System A. The Image Manager in System B is not interested in status information. In this case:

System A claims support of the Post-Processing Workflow Profile as the Post-Processing Manager and DSS Actors.

2820 System B claims support of the Scheduled Workflow Profile as the Image Manager Actor.

Scenario 3:

The Post-Processing Manager is grouped with the DSS in System A. The Image Manager in System B needs status information. In this case:

2825 System A claims support of the Post-Processing Workflow Profile as the Post-Processing Manager and DSS Actors.

System B claims support of the Scheduled Workflow Profile as the Image Manager Actor and implements the optional Performed Work Status Update transaction.

Scenario 4:

2830 A Post-Processing Manager is grouped with the DSS in System A. Another Post-Processing Manager is grouped with the Image Manager in System B. In this case:

System A claims support of the Post-Processing Workflow Profile as the Post-Processing Manager and DSS Actors.

System B claims support of the Post-Processing Workflow Profile as the Post-Processing Manager and Image Manager Actors.

2835 This leaves the site with the decision of how to reconcile control of the post-processing workflow. There are two approaches.

Any system implementing the Post-Processing Manager shall be able to disable this functionality through configuration.

2840 In the first approach, the site selects one of the two systems to be the Post-Processing Manager for the Post-Processing workflow by configuring the other to disable its workflow management functionality.

2845 In the second approach, the site may configure one Post-Processing Manager to start Post-Processing worklists for one set of procedure codes and configure the second Post-Processing Manager to start Post-Processing worklists for a complementary set of procedure codes. Making sure that the procedure code sets are non-overlapping and complementary is a configuration responsibility of the site.

12.3.2 Input Availability

2850 In case of being grouped with the Image Manager, the Post-Processing Manager will have some internal logic to determine when images available are sufficient for the Post-Processing workflow to begin. In some cases, it may not be necessary for a post-processing to be performed. Generally these decisions are based on the procedure code of the requested procedure.

2855 In case of being grouped with the Department System Scheduler, the Post-Processing Manager uses the Image Availability transaction to know when images are available in the Image Archive for query. The image set needed for the Post-Processing workitem might or might not include all the instances the Post-Processing Manager has been notified about via previous MPPS or/and GP-PPS messages related to a requested procedure. Based on the received information and its internal logic the Post-Processing Manager decides which data the Post-Processing workitem input consists of.

2860 Generally, the Post-Processing Manager will create a workitem in the Post-Processing worklist when the required images are available, although it may create the workitem before that with an empty or incomplete Input Information Sequence and the Input Availability Flag set to PARTIAL, until the images are available in the Image Archive.

The Post-Processing Manager and Post-Processing Client (Evidence Creator) must be prepared to handle workitems with PARTIAL image availability in a stable fashion.

2865 The Post-Processing Client may elect not to present workitems with PARTIAL status to the user for selection until their status later changes to COMPLETE. If the Post-Processing Client chooses to let the user select and start work on those items, then the Post-Processing Client is responsible for monitoring the post-processing worklist and make sure the user/application receives the full data when it is available.

2870 Similarly, the Post-Processing Manager may choose to leave workitems with PARTIAL status out of provided worklists until the status is COMPLETE. If the Post-Processing Manager decides to provide PARTIAL workitems in the worklists, then it may be expected to check image

availability and provide updated post-processing worklist replies to queries from the Post-Processing Client for workitems the client claims.

2875 **12.3.3 Evidence Creators in Scheduled Workflow vs. Post-Processing Workflow**

An Evidence Creator that supports the Post-Processing Workflow Profile shall use mechanisms defined in this profile, i.e., General Purpose Performed Procedure Step, for all post-processing tasks including unscheduled tasks.

2880 Evidence Creators that only support the Scheduled Workflow Profile may continue to use the Modality Performed Procedure Step transactions to communicate tasks performed as described in the Scheduled Workflow Profile.

12.4 Post-Processing Process Flow

The following are some possible post-processing use cases.

12.4.1 Computer Aided Detection Use Case

2885 A modality procedure (e.g., a mammography screening exam or a lung CT) is to be acquired and CAD processing is to be performed on the images. The images and CAD processing results will be interpreted together on a review workstation by the reading physician.

2890 The specific actors in this case are Acquisition Modality (digital mammography or CT acquisition system), Evidence Creator/Image Display (CAD processing system), Department System Scheduler, Image Manager/Image Archive, Post-Processing Manager, and Image Display (review workstation).

2895 The Post-Processing Manager is grouped with either the Department System Scheduler or Image Manager and is responsible for providing work to the Evidence Creator. The DICOM Standard services used are Storage of Images (Digital Mammography X-ray or CT), Query/Retrieve, General Purpose Worklist, and Storage of Structured Reports (e.g., Mammography CAD or Chest CAD).

2900 When MPPS Complete has been received and the acquired images are available on the Image Archive, the Post-Processing Manager would add a CAD workitem to the worklist. The CAD processing system would query the worklist, claim the workitem and based on the contained references, retrieve the images from the Image Manager and perform the scheduled CAD processing, reporting the status back to the Post-Processing Manager (including references to result objects created). The generated Evidence documents (CAD processing results) are stored as DICOM Structured Reports (e.g., Mammography CAD or Chest CAD).

2905 The Evidence Document includes references to the images that were analyzed (typically for mammography screening, the MLO and CC views of the left and right breasts), a summary of the algorithms that were executed, including algorithm identification, whether they succeeded or failed, and the findings detected by the algorithms. For example, CAD processing for mammography or lung studies may include identification of the locations of things like suspected densities (masses) and micro-calcifications on the images.

- 2910 Although in this case, the Evidence Creator does not actually create images, just an Evidence Document object (e.g., a CAD object), it is also possible that if the images were enhanced during processing (e.g., a filtered image), new versions of the image might also be stored to the Image Manager. At the end, the Post-Processing Manager is notified with a GP-SPS update that the scheduled step is complete.
- 2915 The images and evidence documents are then available for retrieval by the Image Display Actor on a Review/Reporting system where they can be reviewed by a reading physician and a proper diagnostic report generated. In this way, the profile complements the Simple Image and Numeric Report Profile.

12.4.2 3D Reconstruction Use Case

- 2920 A modality procedure (e.g., a standard CT lumbar spine exam) is to be acquired and reconstructed and the results sent to a 3D post-processing application where Multi-Planar Reconstruction (MPR) is performed to get coronal images of the lumbar spine. The originally created axial images and the new coronal images are interpreted together, either at the modality or on a review station.
- 2925 The specific actors in this case are the Acquisition Modality (e.g., a CT system), Image Display/Evidence Creator (3D workstation), Department System Scheduler, Image Manager/Image Archive, Post-Processing Manager, and Image Display (review workstation).
The Post-Processing Manager is grouped with either the Department System Scheduler or Image Manager and is responsible for providing work to the Evidence Creator. The DICOM Standard services used are Storage of Images (CT), Query/Retrieve, and General Purpose Worklist.
- 2930 When MPPS Complete has been received and the acquired images are available on the Image Archive, the Post-Processing Manager would add a post-processing workitem (GP-SPS) to the worklist. The 3D-processing system would query the worklist, claim the workitem and based on the contained references, retrieve the images from the Image Manager and perform the scheduled
- 2935 MPR processing, reporting the status back to the Post-Processing Manager (including references to result objects created). The MPR result images are stored as DICOM Images (CT). At the end, the Post-Processing Manager is notified with a GP-SPS update that the scheduled step is complete.
- 2940 The images are then available for retrieval by the Image Display Actor on a review/reporting system.

12.4.3 Post-Processing Process Flow Diagrams

The following scenario illustrates a case where an image processing task is performed on acquired images and then a subsequent CAD step is performed on the processed images. The Transaction Summary is depicted for two scenarios:

- 2945
- The Post-Processing Manager is grouped with the Department System Scheduler
 - The Post-Processing Manager is grouped with the Image Manager

2950 The Performed Work Status Update (Started) message must be sent sometime after the Workitem Claimed transaction but at the latest, when the first GP-PPS In Progress is received. In this scenario it is shown right after the Workitem Claimed. Also, it is conceivable that in some scenarios, the processing workstation has loaded potentially useful studies/images prior to claiming the workitem or maybe even before getting the worklist.

Figure 12.4-1: Post-Processing Manager Grouped with Department System Scheduler

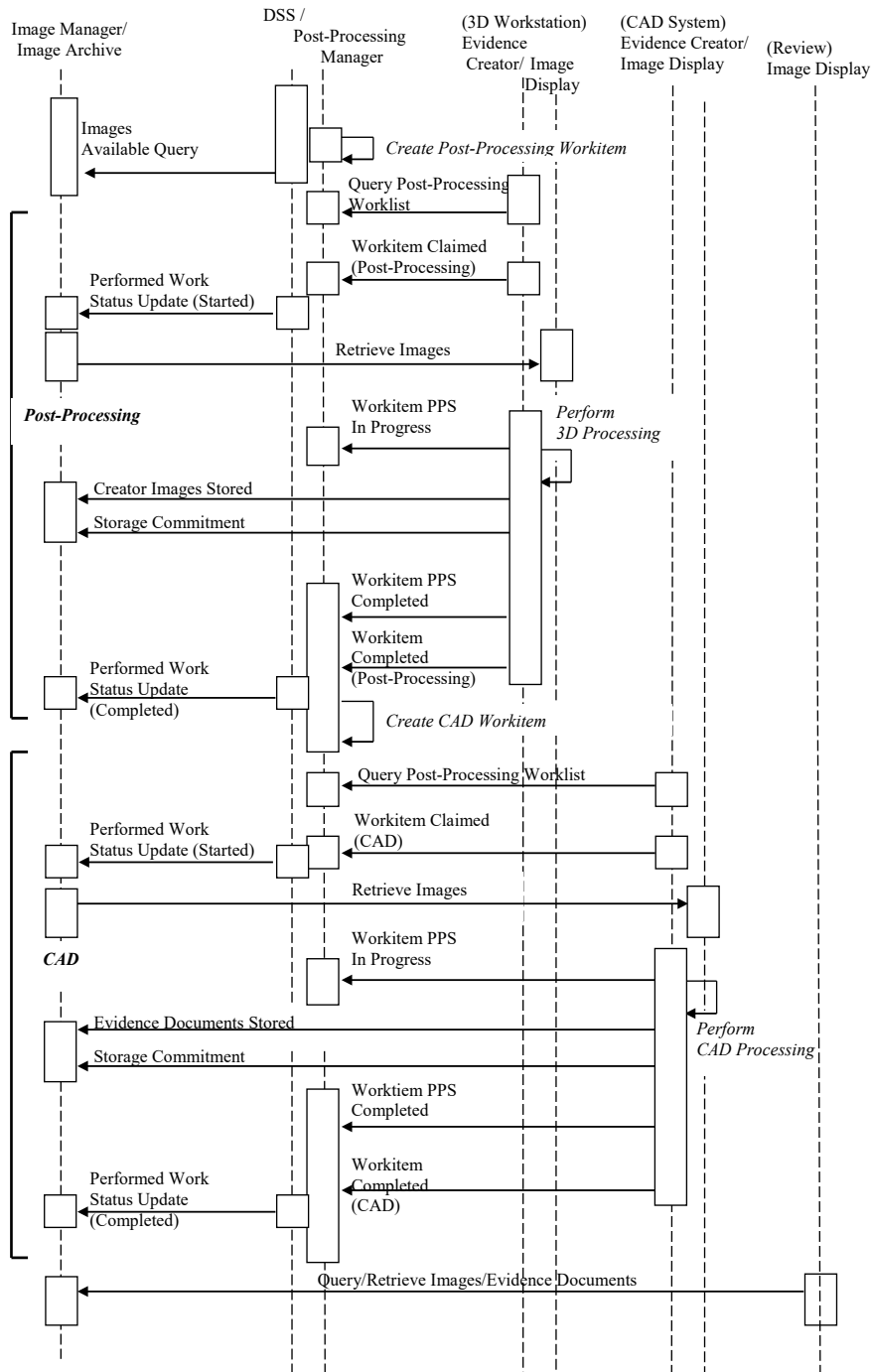

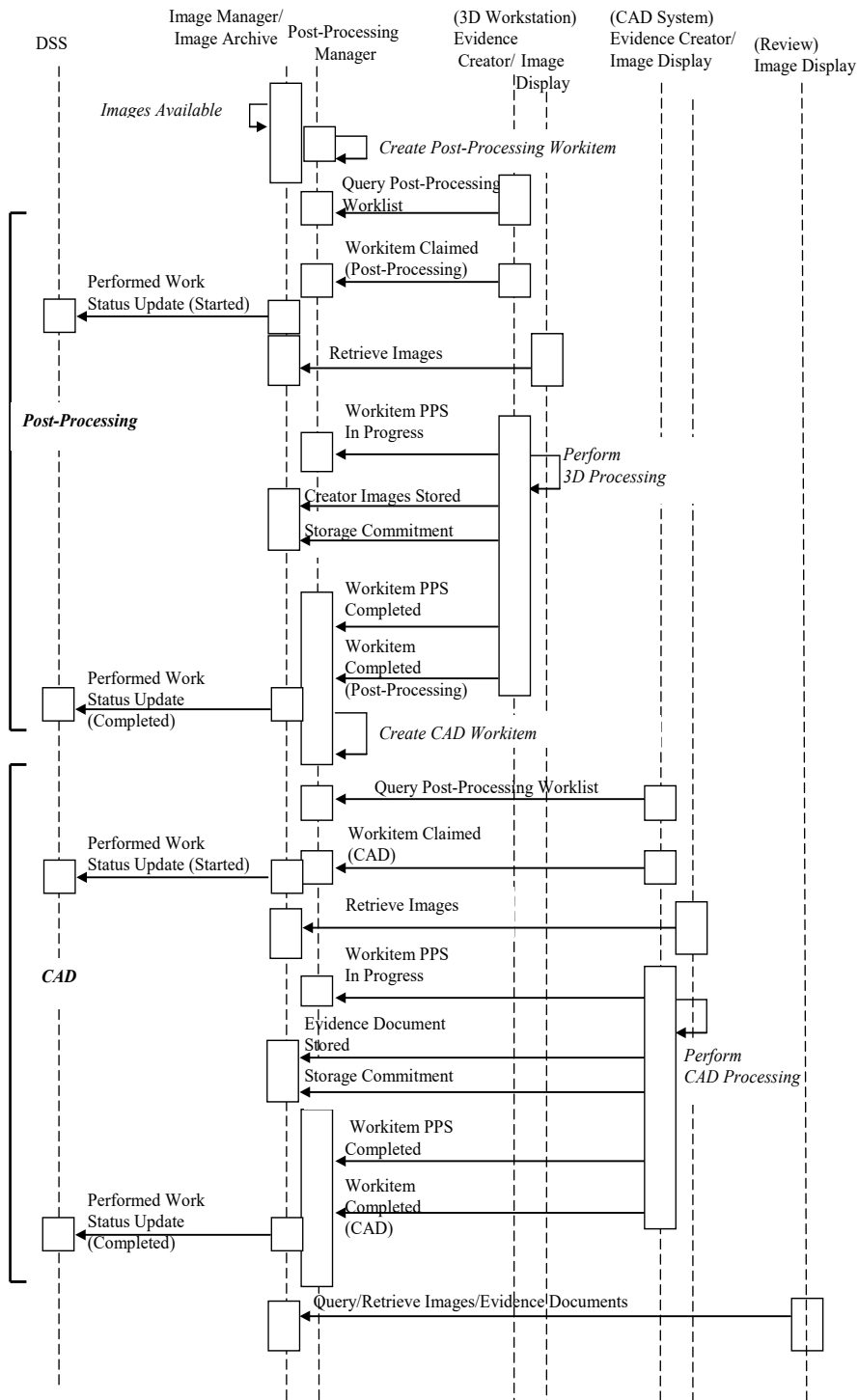

Figure 12.4-2: Post-Processing Manager Grouped with Image Manager

2955

13 Reporting Workflow (RWF)

2960 The Reporting Workflow Profile addresses the need to schedule and track the status of the various reporting tasks. Reporting tasks include interpretation, dictation, transcription, verification, comparison, revision, and coding. Workitems for each of these tasks are generated and can be queried from worklists. Workitems can be claimed. The resulting intermediate and final statuses can be returned from the system performing the work to the system managing the work. The system managing the work also makes the status available for other interested systems in the enterprise.

2965 The output of the Reporting Workflow Profile is defined to be information encoded as DICOM SR objects. The details for creation, storage, query/ retrieve and encoding are described by the Simple Image and Numeric Report (SINR) Profile (see Section 9).

The Reporting Workflow Integration Profile is a continuation of the Scheduled Workflow Integration Profile.

2970 13.1 Actors/Transactions

Figure 13.1-1 shows the actors directly involved in the Reporting Workflow Integration Profile and the relevant transactions between them. Other actors that may be indirectly involved due to their participation in the Scheduled Workflow, etc. are not necessarily shown. Image Display can participate in this profile if it is grouped with a Report Creator.

2975

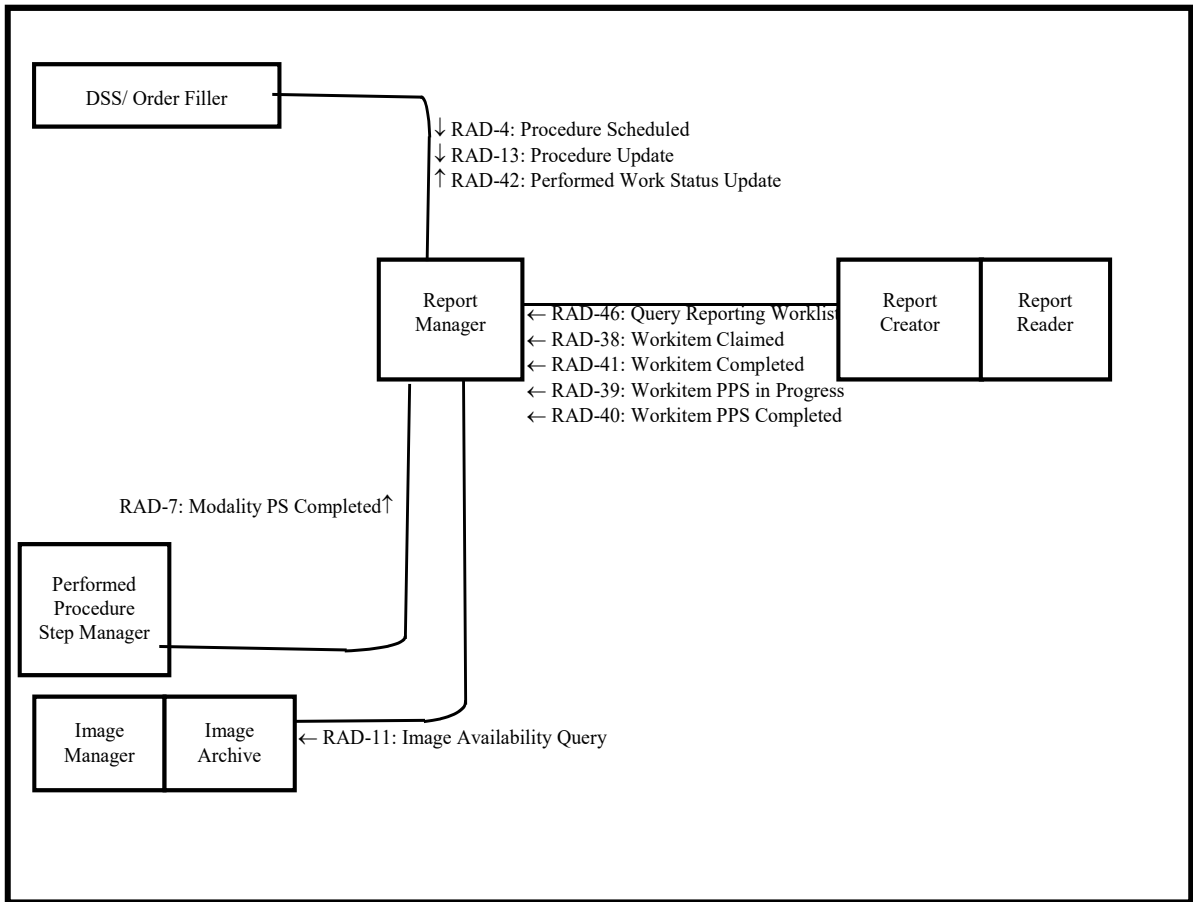

Figure 13.1-1: Reporting Workflow Actor Diagram

2980 Table 13.1-1 lists the transactions for each actor directly involved in the Reporting Workflow Integration Profile. In order to claim support of this Integration Profile, an implementation must perform the required transactions (labeled “R”). Transactions labeled “O” are optional. A complete list of options defined by this Integration Profile and that implementations may choose to support is listed in Section 13.2.

Table 13.1-1: Reporting Workflow Integration Profile - Actors and Transactions

Actors	Transactions	Optionality	TF Reference
Department System Scheduler/ Order Filler	Procedure Scheduled [RAD-4]	R	RAD TF-2: 4.4
	Procedure Update [RAD-13]	R	RAD TF-2: 4.13
	Performed Work Status Update (Receive) [RAD-42]	R	RAD TF-3: 4.42
Image Manager/ Image Archive	Images Availability Query [RAD-11]	R	RAD TF-2: 4.11
	Query Images [RAD-14]	R	RAD TF-2: 4.14
	Retrieve Images [RAD-16]	R	RAD TF-2: 4.16

Actors	Transactions	Optionality	TF Reference
Report Creator (Report Reader)	Query Reporting Worklist [RAD-46]	R	RAD TF-3: 4.46
	Workitem Claimed [RAD-38]	R	RAD TF-3: 4.38
	Workitem PPS In Progress [RAD-39]	R	RAD TF-3: 4.39
	Workitem PPS Completed [RAD-40]	R	RAD TF-3: 4.40
	Workitem Completed [RAD-41]	R	RAD TF-3: 4.41
Report Manager	Procedure Scheduled [RAD-4]	R	RAD TF-2: 4.4
	Images Availability Query [RAD-11]	R	RAD TF-2: 4.11
	Procedure Update [RAD-13]	R	RAD TF-2: 4.13
	Query Reporting Worklist [RAD-46]	R	RAD TF-3: 4.46
	Workitem Claimed [RAD-38]	R	RAD TF-3: 4.38
	Workitem PPS In Progress [RAD-39]	R	RAD TF-3: 4.39
	Workitem PPS Completed [RAD-40]	R	RAD TF-3: 4.40
	Workitem Completed [RAD-41]	R	RAD TF-3: 4.41
	Performed Work Status Update (send) [RAD-42]	R	RAD TF-3: 4.42
Modality Performed Procedure Step Completed [RAD-7]	R	RAD TF-2: 4.7	
Performed Procedure Step Manager	Modality Performed Procedure Step Completed [RAD-7]	R	RAD TF-2: 4.7

Refer to Table 2-1 for other profiles that may be pre-requisites for this profile.

2985 13.1.1 Actor Grouping Clarification

Any system implementing the Report Manager will have some internal logic to determine when images stored on the Image Manager are sufficient for the reporting workflow to begin. In some cases, it may not be necessary for a report to be generated. Generally, these decisions are based on the procedure code of the requested procedure.

2990 This profile is currently designed with the following grouping scenarios in mind:

Scenario 1:

The Report Manager is grouped with the Image Manager in System A. The DSS in System B needs status information. In this case:

2995 System A claims support of the Reporting Workflow Profile as the Report Manager and Image Manager Actors.

System B claims support of the Scheduled Workflow Profile as the DSS Actor and implements the optional Performed Work Status Update transaction.

Scenario 2:

3000 The Report Manager is grouped with the DSS in System A. The Image Manager in System B needs status information. In this case:

System A claims support of the Reporting Workflow Profile as the Report Manager and DSS Actors.

System B claims support of the Scheduled Workflow Profile as the Image Manager Actor.

Scenario 3:

3005 A Report Manager is implemented on a system A and is grouped with neither the DSS nor the Image Manager. The DSS in system B needs status information. The Image Manager in System C might or might not need the status information. In this case:

System A claims support of the Reporting Workflow Profile as the Report Manager Actor.

3010 System B claims support of the Scheduled Workflow Profile as the DSS Actor and implements the Performed Work Status Update transaction.

System C claims support of the Scheduled Workflow Profile as the Image Manager Actor and may implement the optional Performed Work Status Update transaction if the needed.

13.1.2 Input Availability

3015 The Report Manager uses the Images Availability Query transaction to know when images are available in the Image Archive for query. The image set relevant for the reporting workflow might or might not include all the instances the Report Manager has been notified about via previous MPPS or/and GP-PPS messages related to a requested procedure. Based on the received information and its internal logic the Report Manager decides which data the reporting workitem input consists of.

3020 Generally, the Reporting Manager will create a workitem in the reporting worklist when the required images are available, although it may create the workitem before that with an incomplete Input Information Sequence and the Input Availability Flag set to PARTIAL. The Reporting Manager and Report Creator must be able to handle workitems with PARTIAL image availability in a stable way. The Report Creator may not display workitems with PARTIAL status to the user for selection until their status later changes to COMPLETE. If the Report Creator allows the user to select and start work on items with partially available input, then the Report Creator is responsible for monitoring the reporting worklist and make sure the user receives the full data when it is available.

3030 Similarly, the Report Manager may choose to leave workitems with PARTIAL status out of the provided worklist until the status is COMPLETE. If the Report Manager provides workitems with partially available input data in the worklist, then a later check of the image availability and update of the workitem in the worklist may be expected even for workitems that have been already claimed.

13.2 Reporting Workflow Integration Profile Options

3035 Options that may be selected for this Integration Profile are listed in the Table 13.2-1 along with the Actors to which they apply. Dependencies between options when applicable are specified in notes.

Table 13.2-1: Reporting Workflow - Actors and Options

Actor	Options	TF Reference
Department System Scheduler / Order Filler	HL7 v2.5.1	RAD TF-1: 13.2.1 RAD TF-2: 4.4 RAD TF-2: 4.13
Image Manager/ Image Archive	<i>No options defined</i>	-
Report Creator	<i>No options defined</i>	-
Report Manager	HL7 v2.5.1	RAD TF-1: 13.2.1 RAD TF-2: 4.4 RAD TF-2: 4.13
Report Reader	<i>No options defined</i>	-
Performed Procedure Step Manager	<i>No options defined</i>	

3040 13.2.1 HL7 v2.5.1 Option

The HL7 v2.5.1 Option requires actors to support HL7 v2.5.1 in addition to HL7 v2.3.1 in the transactions referenced in Table 13.2-1. The actor shall permit configuration for each system that it communicates with using the referenced transactions whether HL7 v2.3.1 or HL7 v2.5.1 is used. It is possible that the actor may receive HL7 v2.3.1 messages and send HL7 v2.5.1 messages or vice versa.

3045

The specifications in the HL7 v2.5.1 Option maintain semantic equivalency with HL7 v2.3.1 implementations and the field correspondences are summarized in RAD TF-2: Appendix E.

13.3 Reporting Tasks

The process of report creation is considered to be composed of multiple tasks. The following individual tasks have been identified:

3050

- Interpretation - the physician accesses the acquired images, reviews them and typically generates either a draft report or dictation.
- Interpretation and Dictation - the physician generates an audio file of dictated observations that will make up the diagnostic report's content.
- Transcription - the transcriptionist accesses the physician's dictated report and generates the transcribed text report.
- Verification - the physician accesses the transcribed or draft report, confirms the text content accuracy and generates the verified report.
- Review - the physician accesses the report, reviews the content and may generate either an agreement or disagreement.
- Comparison - the physician accesses two verified reports, reviews the content, and generates either a difference report or confirmation of similarity.

3055

3060

- Coding - the coder accesses a draft or verified report, and assigns codes.

3065

Note: Verification is considered to be different from a signature, although it may trigger a signature. A signature has policies attached to it. It is not part of this Reporting Workflow profile.

In the report creation process, actors such as the report creator perform relevant workitems obtained by querying the relevant worklist.

3070

Depending on the capabilities of the system containing the Report Creator Actor and the permissions of the user, it may be possible to carry out several steps at once. For example, a speech recognition workstation may support interpretation, dictation and transcription all at once, and a senior physician may have authority to immediately verify the resulting report. In other situations or implementations, it may be necessary to perform the steps separately. The types and sequence of tasks may vary from site to site. A sequential process made up of an interpretation/dictation, a transcription, and a verification task is very common, but this can vary between institutions.

3075

The logic of determining what tasks to schedule and when to schedule them is the responsibility of the Report Manager and is not defined by IHE. Typically, this logic will involve completion of pre-requisite tasks and/or availability of needed input objects. Much of the needed information is available in the PPS Transactions from the Report Creators, Image Managers and other actors, in the Image Availability Transaction to the Image Manager, and in reports stored to the Report Manager.

3080

The logic of presenting a relevant list of workitems to the user is the responsibility of the Report Creator and is only partially defined by IHE in the Query Reporting Worklist transaction. Typically, this will involve filtering the available workitems based on the Scheduled Workitem Code (to find particular types of tasks), the Scheduled Human Performer (to find work for a particular person), the Scheduled Station Name (to find work for a particular workstation), Patient Name (to find work for a particular patient), Accession Number (to find work for a particular order), or Procedure Step Status (to find work in a particular state).

3085

A number of common workitem codes are listed in RAD TF-3: 4.46 - Query Reporting Worklist. Systems may allow sites to configure additional codes that reflect their local workflow practices and can be used by the Report Creators to filter workitems.

3090

As the Report Creator completes tasks, it reports performed workitem codes to the Report Manager. This is particularly important when the Report Creator performs additional tasks as it enables the Report Manager to modify the workflow. Further robustness and flexibility is provided by allowing the Report Creator to identify and suggest subsequent workitem codes in the General Purpose Performed Procedure Step Results Module, giving the Report Manager additional input to the logic it uses to select subsequent workflow steps in an adaptive manner.

3095

The following diagram (Figure 13.3-1, parts 1 & 2) gives an example of a full Reporting Workflow from scheduling of the initial Interpretation/Dictation task, to the final release of the verified report. Prior to the start of this, images and evidence documents would have been stored to the Image Manager and PPS transactions containing references to those objects sent to the Report Manager.

3100

In this example, the Report Manager is grouped with neither the DSS nor the Image Manager, and the DSS is acting as the Performed Procedure Step Manager.

3105 In the figure(s) below, there are parenthetic notations associated with most of the Query Reporting Worklist and Workitem PPS In-Progress/ Completed transactions. These notes indicate the Scheduled or Performed Workitem Codes associated with those transactions. For a complete set of codes, refer to RAD TF-3: Table 4.46-4.

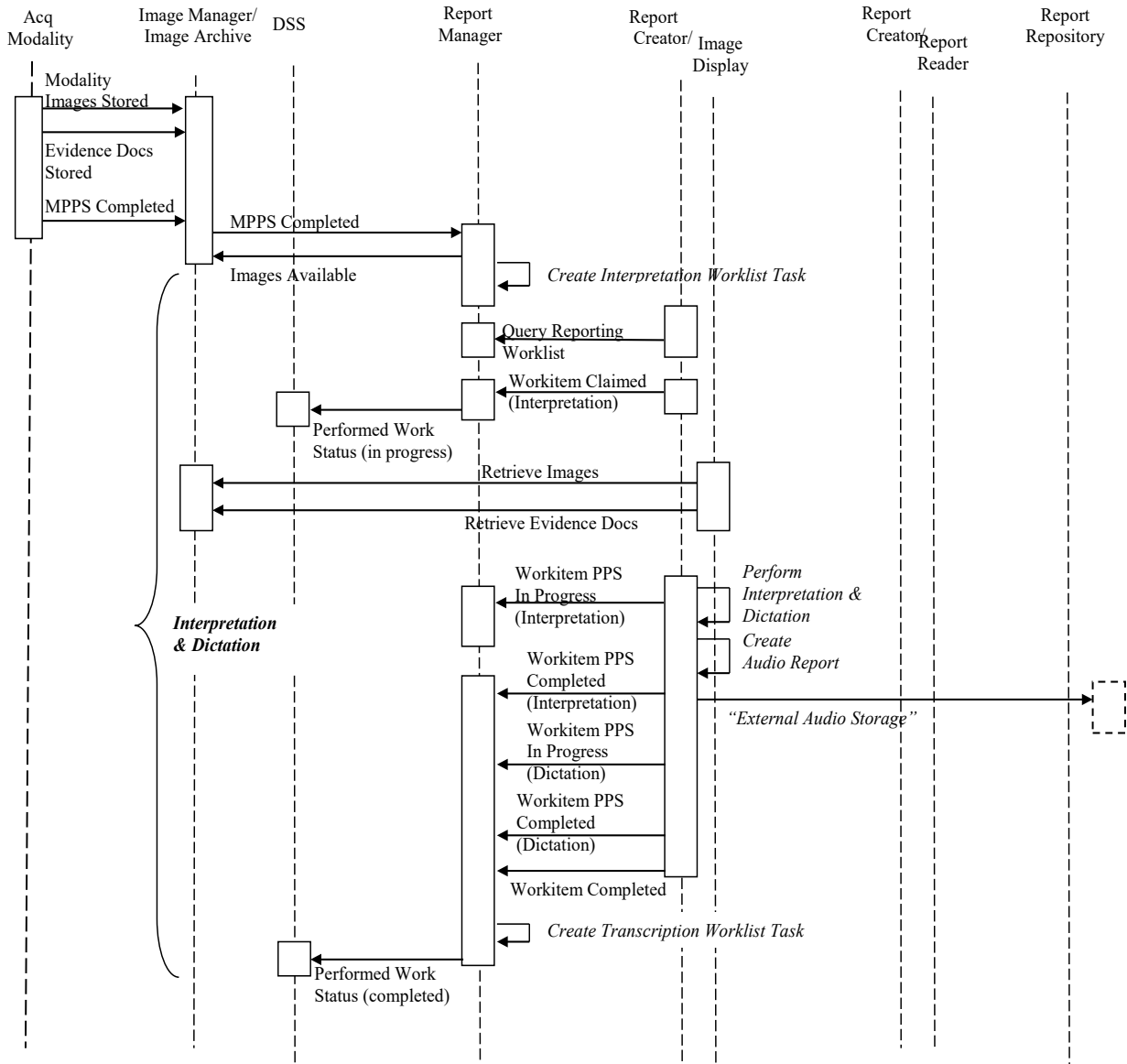

3110

Figure 13.3-1 (part 1): Reporting Workflow Overall Sequence

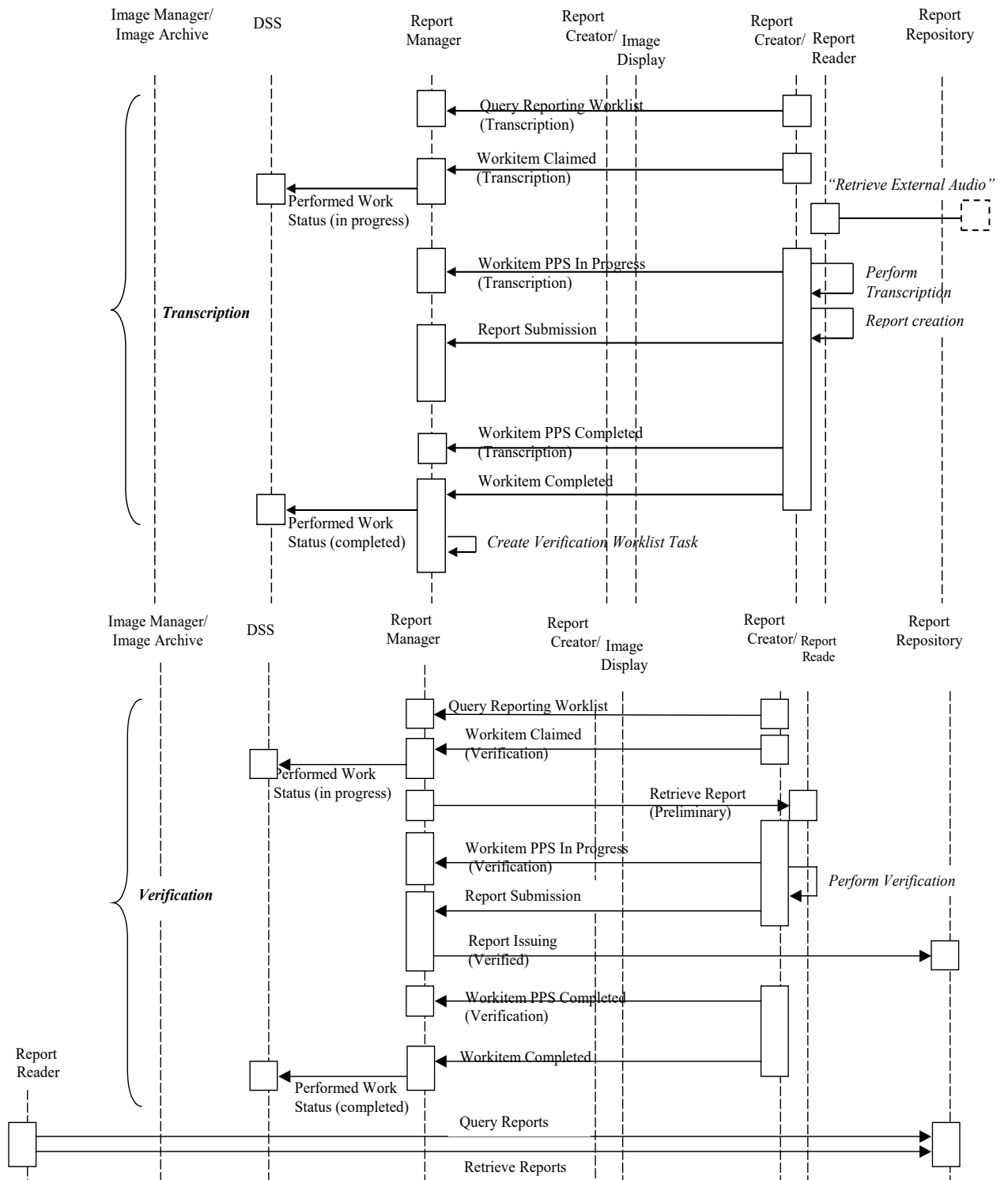

Figure 13.3-1 (part 2): Reporting Workflow Overall Sequence

3115 **13.4 Diagnostic Reporting Use Cases**

This section describes diagnostic reporting creation uses cases. Each use case is a combination of one or many reporting tasks. These use cases do not cover all reporting use cases. However, their feasibility is demonstrated.

13.4.1 Use case 1: Predefined Report

3120 The primary user is the reading physician. When interpreting a study, the user chooses a report from a list of pre-configured draft reports and can edit the report's content in order to customize it. This use case covers the situation where the user can use a predefined/ canned report (which is frequently the case when the results are normal), and has permission to verify the report.

This use case finally results in:

- 3125
- multiple Performed Procedure Steps for each of the performed workitems Interpretation, Transcription and Report Verification, each having a corresponding code value in the Performed Workitem Code Sequence;
 - a report which has been verified and is referenced in the output results status message;
 - removing the workitem from the worklist, after the workitem status was set to completed.

3130

The basic flow is illustrated in Figure 13.4-1

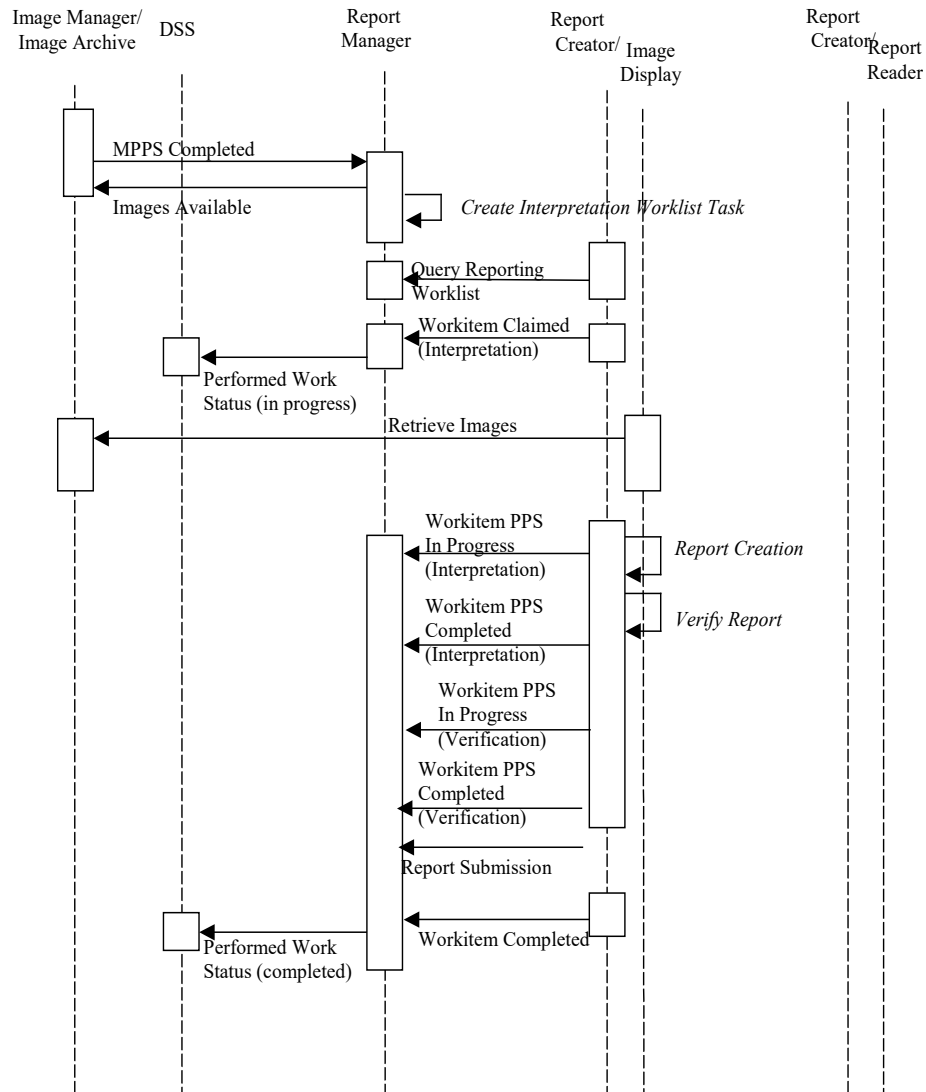

Figure 13.4-1 Use Case 1: Predefined Report

13.4.2 Use case 2: Workitem Deferred

3135 The primary user can be the reading physician, the transcriptionist, or the verifying physician. This use case takes place when the user starts to work on the workitem and decides not to complete it.

At the end of this use case the workitem status is set to scheduled and the workitem remains in the worklist.

3140 The basic flow is illustrated in Figure 13.4-2 (optional transactions denoted by dotted lines). Transactions Workitem PPS In Progress and Workitem PPS Completed are optional since some implementations may let the user skip before sending these transactions

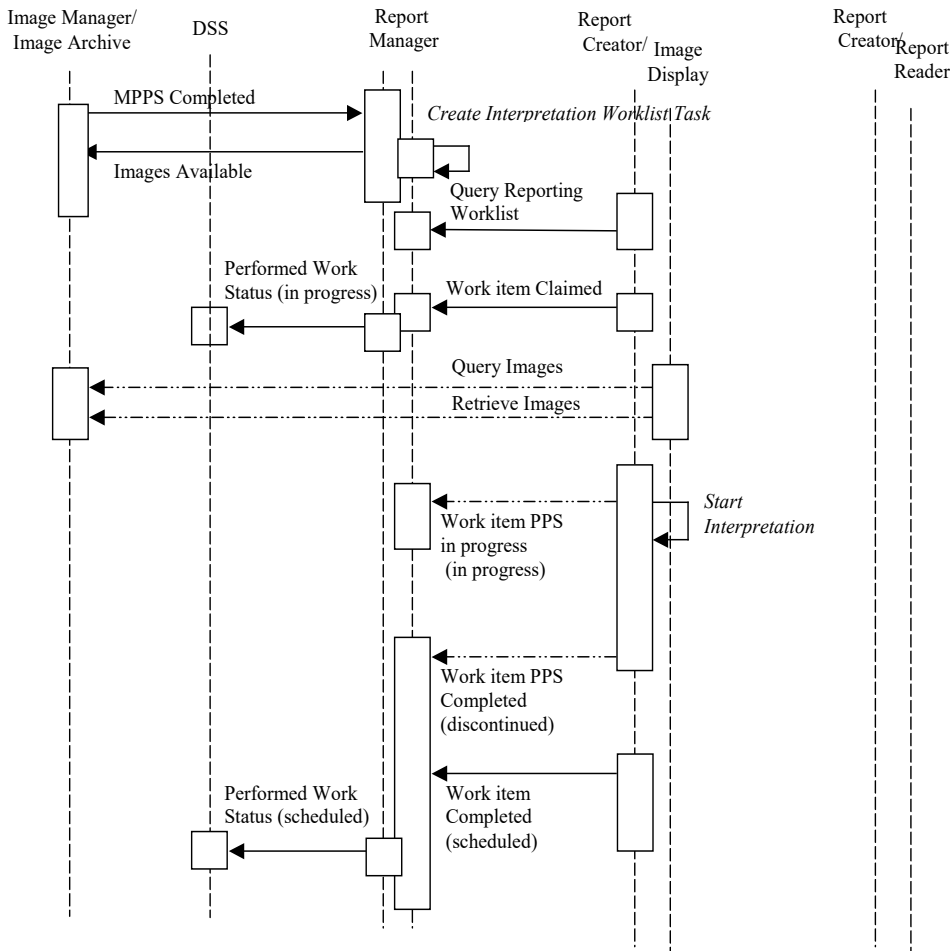

Figure 13.4-2 Use Case 2: Workitem Deferred

3145 **13.4.3 Use case 3: Direct Report Creation**

The primary user is the reading physician. This use case takes place when the user creates the report's content. The user may define a template or choose a template from pre-defined ones to fill in. The major difference between this use case and the "Predefined Report" use case (Section 13.4.1) is that in this use case, the user is expected to have to perform more "customization/ tailoring" of the report content (i.e., in contrast to the 'canned report' nature of the Predefined Report case).

3150

At the end of this use case the workitem status is set to completed, the workitem is removed from the worklist, a report is generated, the output results status message references the generated report, the suggested subsequent workitem is set to Report Verification and the multiple Performed workitem code sequences include Interpretation and Transcription.

3155

The basic flow is illustrated in Figure 13.4-3.

This use case has an extension when the user has verification permission. In this case the generated report is verified, and the multiple Performed workitem code sequences include Interpretation, Transcription and Report Verification.

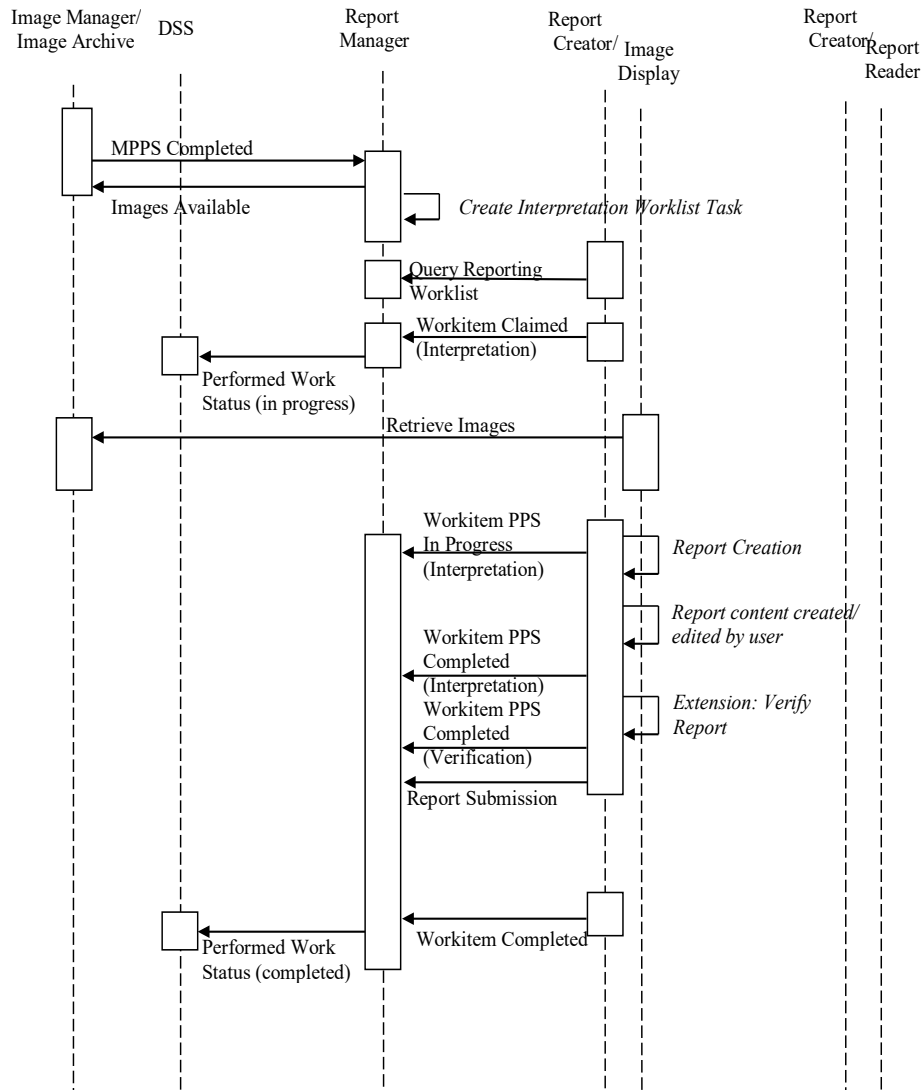

3160

Figure 13.4-3 Use Case 3: Direct Report Creation

13.4.4 Use case 4: Interpretation and Dictation

The primary user is the reading physician. This use case takes place when the user dictates the interpretation.

3165 This use case finally results in:

- multiple Performed Procedure Steps for each of the performed workitems Interpretation and Dictation, each having a corresponding code value in the Performed Workitem Code Sequence;

- an output results status message, referencing the generated audio file and suggesting its Transcription as subsequent workitem;
- removing the workitem from the worklist, after the workitem status was set to completed.

The basic flow is illustrated in Figure 13.4-4 (optional transactions denoted by dotted lines).

NOTE: It is beyond the scope of the Radiology Technical Framework to define the “External Audio Storage” transaction shown in this figure.

This use case has two variations. The first variation is when a voice recognition system is available at the Report Creator. In this case a report is generated, the output results reference the generated report, the suggested subsequent workitem is set to Report Verification, and two Performed Procedure Steps are created each having a Performed Workitem Code Sequence value of Interpretation or Transcription respectively. The second variation takes place when a voice recognition system is available at the Report Creator and the user has verification permission. In this case the generated report is verified, and three Performed Procedure Steps are created each having a Performed Workitem Code Sequence value of Interpretation, Transcription or Report Verification respectively.

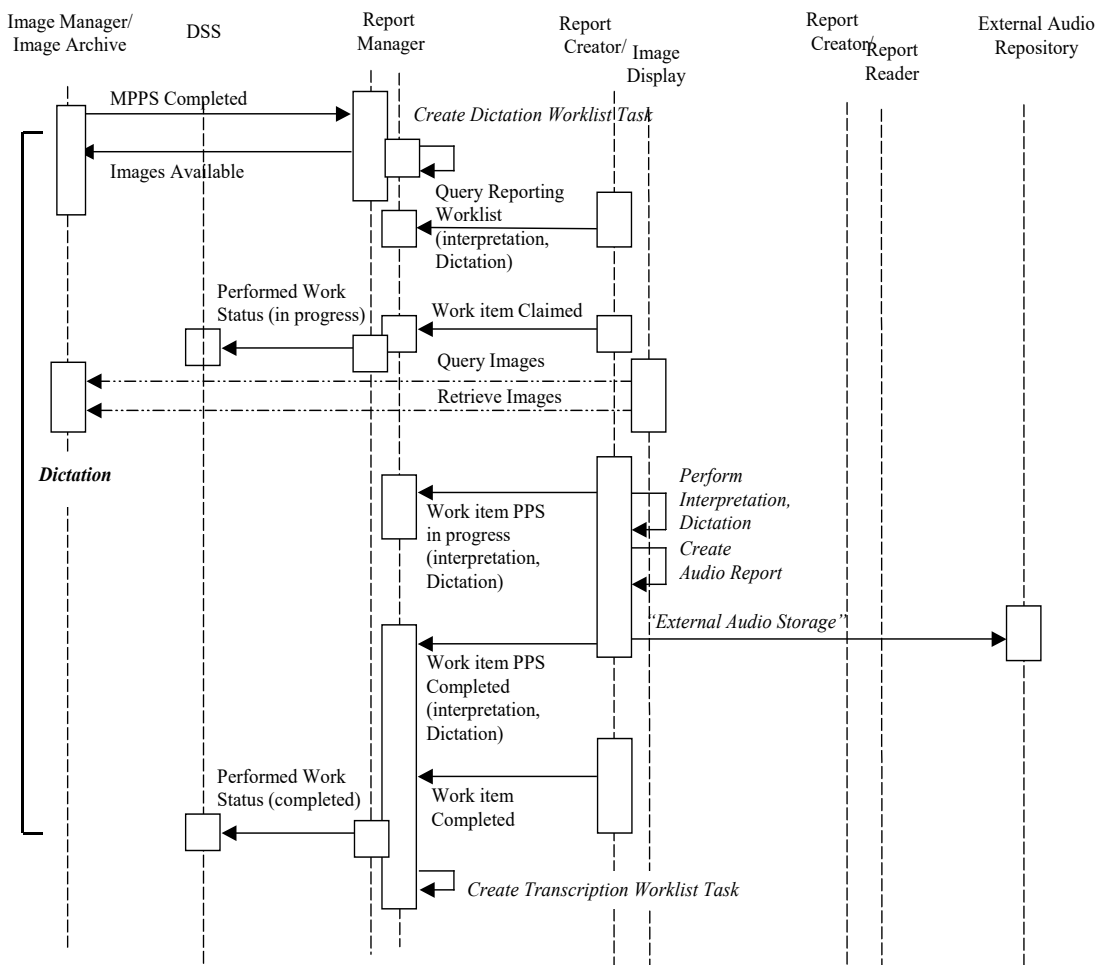

3185 **Figure 13.4-4 Use Case 4: Interpretation and Dictation**

13.4.5 Use case 5: Transcription

The primary user is the transcriptionist. This use case can start when an audio file is available, and takes place when the transcriptionist transcribes the audio content into a transcribed report.

This use case finally results in:

- 3190 • a Performed Procedure Step for Transcription, having a corresponding code value in its Performed Workitem Code Sequence;
- an output results status message, referencing the generated report and suggesting its Verification as subsequent workitem;
- removing the workitem from the worklist, after the workitem status was set to completed.

3195 The basic flow is illustrated in Figure 13.4-5.

NOTE: It is beyond the scope of the Radiology Technical Framework to define the “Retrieve External Audio” transaction shown in this figure.

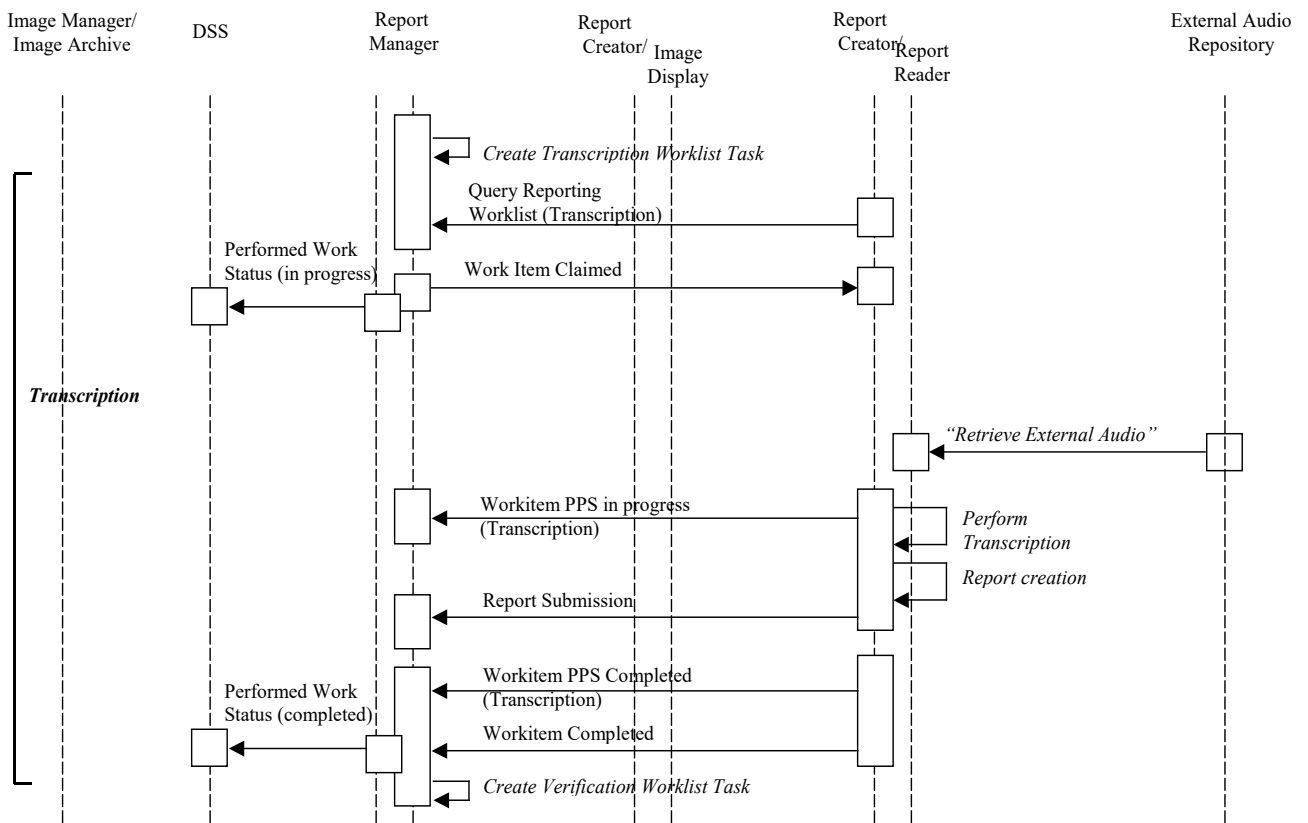

Figure 13.4-5 Use Case 5: Transcription

3200 13.4.6 Use case 6: Partial completion

The primary user is the reading physician.

3205 This use case happens when the user begins the task and then decides that this task cannot be completed at this moment. The reason can be that more input is necessary to perform this task such as additional image acquisition, post- processing (3D) or that the actual data is of bad quality and new acquisition is required. This may require a new scheduling and a new workitem when interpretation would be possible again

At the end of this use case the workitem status is set to discontinued, and the workitem is removed from the worklist.

3210 The Report Creator may decide whether sending partial results to the Report Manager (via the Workitem PPS transactions) is useful.

The basic flow is illustrated in Figure 13.4-6 (optional transactions denoted by dotted lines).

Preferably the Report Manager would need to know about the reason for discontinuation. However, this is not possible actually with the DICOM GP PPS transaction. It will be included later when this becomes possible.

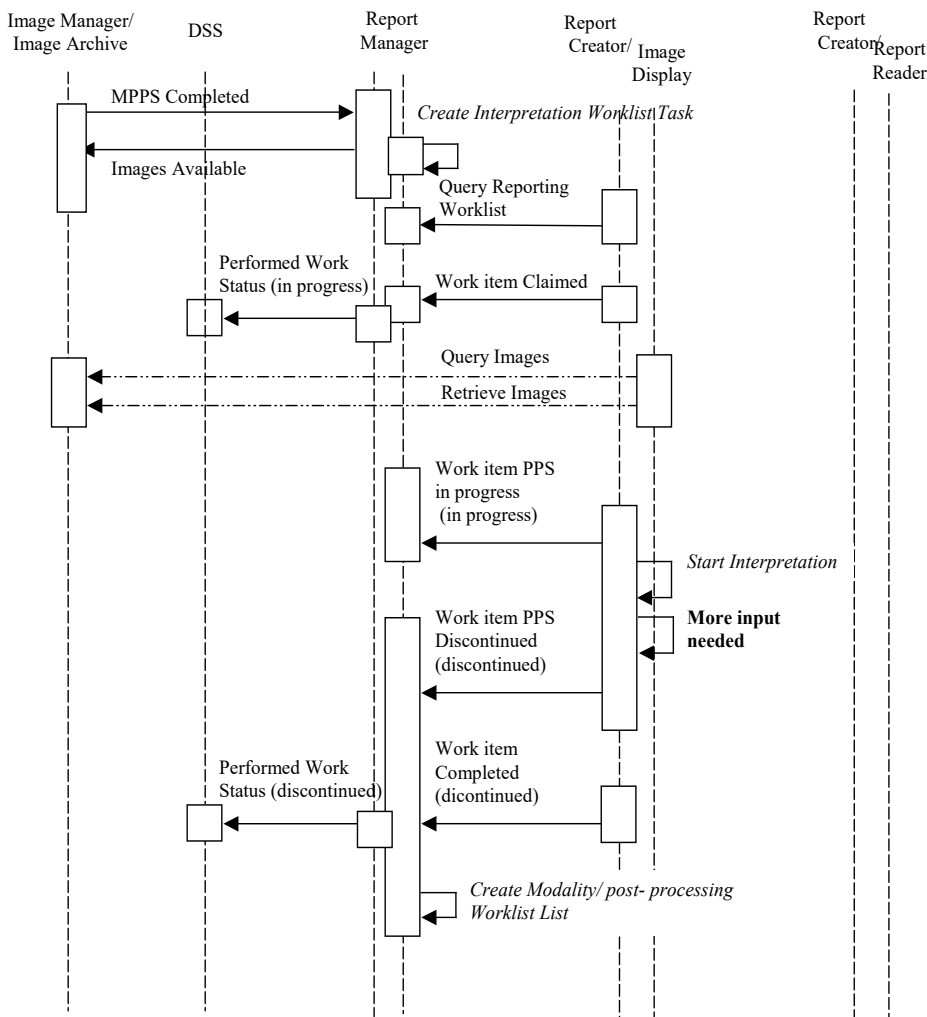

3215

Figure 13.4-6 Use Case 6: Partial Completion

13.4.7 Use case 7: Verification

The primary user is the verifying physician.

3220 This use case can start when a non-verified report needs verification. Verification is a confirmation of the correctness of the report’s content. It is NOT a legal signature. For DICOM SR instances, verification results in setting the Verification Flag value to “VERIFIED”.

This use case finally results in:

- a Performed Procedure Step for Report Verification, having a corresponding code value in its Performed Workitem Code Sequence;
- 3225 • an output results status message, referencing the verified report;
- removing the workitem from the worklist, after the workitem status was set to completed.

The basic flow is illustrated in Figure 13.4-7.

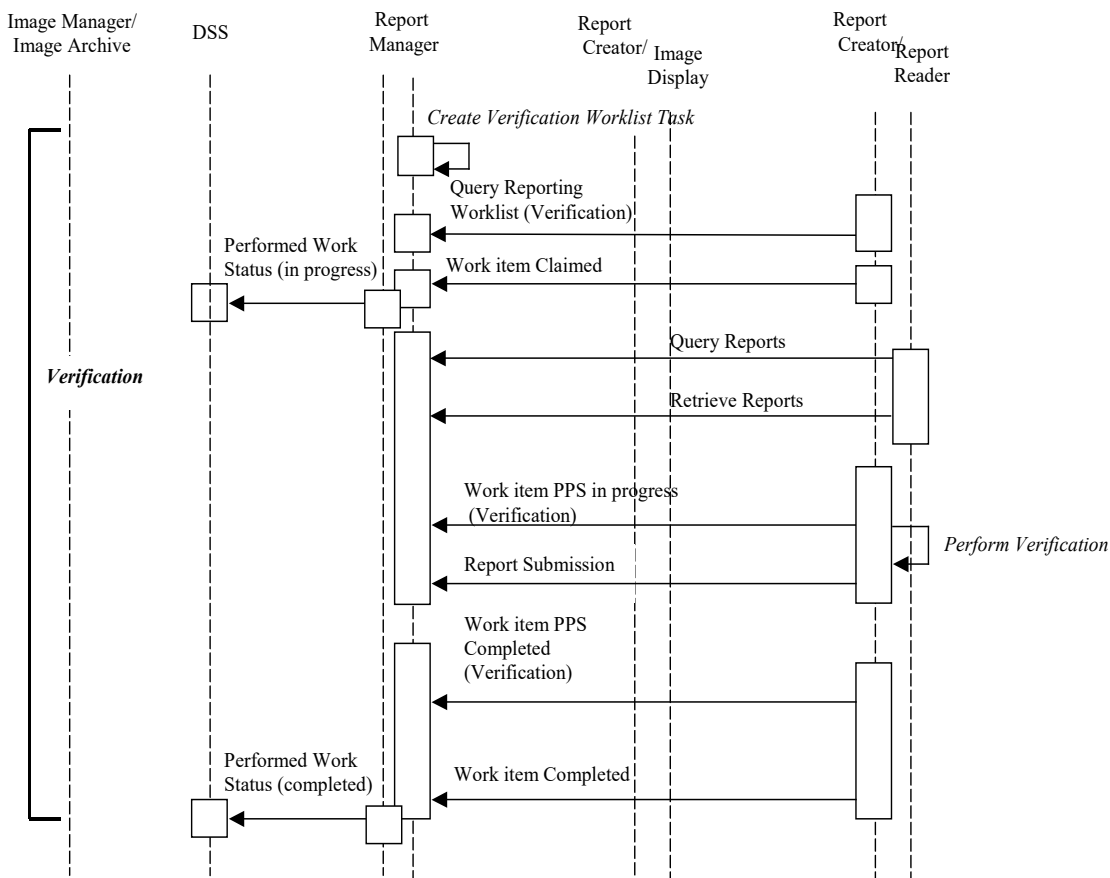

Figure 13.4-7 Use Case 7: Verification

3230 This use case has an extension when the user needs to correct the report’s content by dictation. In this case the report is not verified, the output results reference the unverified report and the audio

file, the Performed workitem code sequence includes Report Verification, and the suggested subsequent workitem set to Transcription.

13.4.8 Use case 8: Double reading

3235 The primary user is the reading physician.

This use case takes place when two report objects are needed for the same requested procedure.

The Report Manager generates two reporting workitems. Each workitem is processed separately according to use cases 1 to 7. Once both verified reports are generated, they are compared according to the comparison use case.

13.4.9 Use case 9: Comparison

The primary user is the reading physician

This use case takes place when there are two verified reports for the same requested procedure to be compared.

3245 At the end of this use case, the user finds the reports either similar or different. In the case of a disagreement, a discrepancy report is generated.

The basic flow is illustrated in Figure 13.4-8. This flow assumes that the reports being compared have been submitted to the Report Manager.

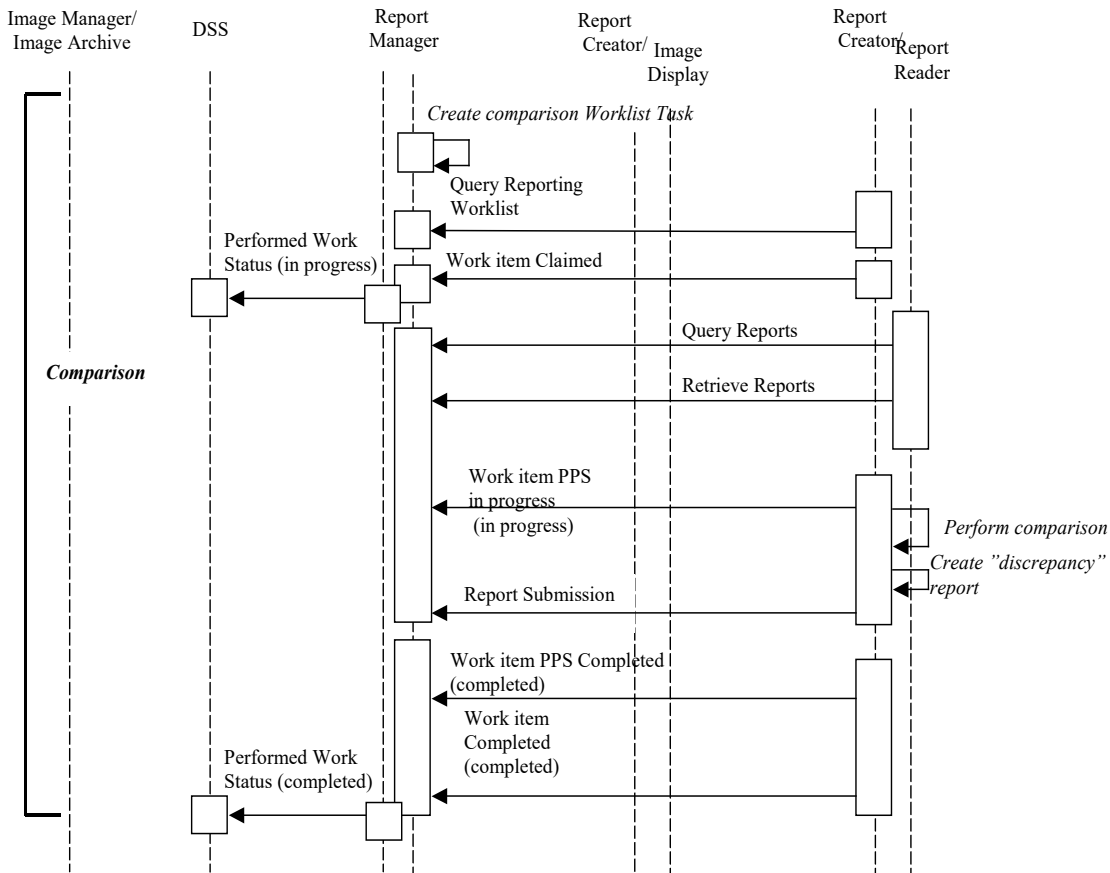

Figure 13.4-8 Use Case 9: Comparison

3250 **13.4.10 Use case 10: Review**

The primary user is the reading physician. This use case takes place when the user needs to review the report’s content already verified by another physician. For example, this can happen when a physician returns from vacation and must review the work done on his behalf by a colleague. In this case, the Report Manager would schedule Review workitems either based on a request from the user, the administrator, or automatically based on department policy and the user being marked as “back”.

3255

Another scenario is in an “educational setting” where a ‘student’ is given a list of reports done by a more senior colleague to review with the purpose of learning from it.

13.4.11 Use case 11: Over Read

3260 The primary user is the reading physician. This is often done for the purposes of quality assurance on the reading process.

In this use case the Report Manager generates two reporting workitems for the same requested procedure intended to be performed sequentially. The first verified report is used as input into second reporting workitem. Each workitem is processed separately according to use cases 1 to 7.

3265 At the end of this use case, the user performing the “over read” either agrees or disagrees with the original report’s content. In the case of an agreement, an additional ‘Verifying Observer Sequence’ is added to the original report object. In the case of a disagreement, a discrepancy report is generated.

3270 **14 Evidence Documents (ED)**

The Evidence Documents Profile allows detailed non-image information, such as measurements, CAD results, procedure logs, etc. to be made available as input to the process of generating a diagnostic report either as additional evidence for the reporting physician or in some cases for selected items in the Evidence Document to be included in the diagnostic report.

3275 The process of creating and using Evidence Documents can be managed by worklists that provide patient/ procedure details and by performed procedure steps that report status information (e.g., see Integration Profiles on Scheduled Workflow, Post-Processing Workflow, Reporting Workflow).

3280 Evidence Documents represent one of the inputs to the reporting process described in the Reporting Workflow Profile and may provide details which get included in diagnostic reports described in the Simple Image & Numeric Reports Profile.

It should be noted that while Key Image Notes meet the definition of Evidence Documents, they are a special case which is dealt with separately in the Key Image Notes Profile for historical reasons.

3285 **14.1 Actors/Transactions**

Figure 14.1-1 shows the actors directly involved in the Evidence Documents Integration Profile and the relevant transactions between them. Other actors that may be indirectly involved due to their participation in Scheduled Workflow, etc. are not necessarily shown.

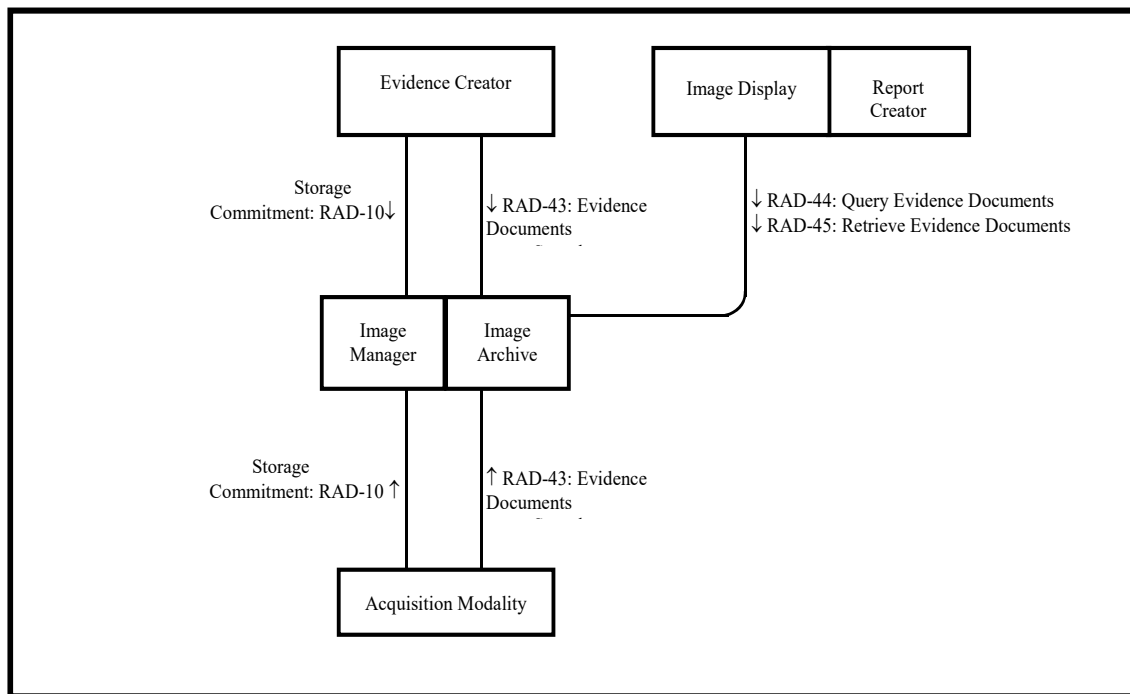

3290 **Figure 14.1-1: Evidence Documents Actor Diagram**

3295 Table 14.1-1 lists the transactions for each actor directly involved in the Evidence Documents Profile. In order to claim support of this integration profile, an implementation must perform the required transactions (labeled “R”). Transactions labeled “O” are optional. A complete list of options defined by this integration profile and that implementations may choose to support is listed in Section 14.2.

Table 14.1-1: Evidence Document Integration Profile - Actors and Transactions

Actors	Transactions	Optionality	TF Reference
Evidence Creator	Storage Commitment [RAD-10]	R	RAD TF-2: 4.10
	Evidence Documents Stored [RAD-43]	R	RAD TF-3: 4.43
Acquisition Modality	Storage Commitment [RAD-10]	R	RAD TF-2: 4.10
	Evidence Documents Stored [RAD-43]	R	RAD TF-3: 4.43
Image Manager/ Image Archive	Storage Commitment [RAD-10]	R	RAD TF-2: 4.10
	Evidence Documents Stored [RAD-43]	R	RAD TF-3: 4.43
	Query Evidence Documents [RAD-44]	R	RAD TF-3: 4.44
	Retrieve Evidence Documents [RAD-45]	R	RAD TF-3: 4.45
Image Display (Report Creator)	Query Evidence Documents [RAD-44]	R	RAD TF-3: 4.44
	Retrieve Evidence Documents [RAD-45]	R	RAD TF-3: 4.45

Note: Refer to Table 2-1 for other profiles that may be pre-requisites for this profile.

3300 If a Report Creator wishes to participate in this profile, it does not have to support any transactions directly, however it is required to be grouped with an Image Display in order to be able to Query/Retrieve the Evidence documents, and the Report Creator is expected to be able to transfer some contents of the retrieved document into the report it creates.

14.2 Evidence Documents Integration Profile Options

3305 Options that may be selected for this integration profile are listed in the Table 14.2-1 along with the Actors to which they apply. Dependencies between options when applicable are specified in notes.

Table 14.2-1: Evidence Documents - Actors and Options

Actor	Options	TF Reference
Evidence Creator	<i>No options defined</i>	--
Acquisition Modality	<i>No options defined</i>	--
Image Manager/ Image Archive	<i>No options defined</i>	--
	<i>No options defined</i>	--
Image Display (Report Creator)	<i>No options defined</i>	--
	<i>No options defined</i>	--

The Evidence Creator, Acquisition Modality and Image Manager/ Image Archive will likely support a variety of DICOM SOP Classes. Each DICOM SOP Class that is supported by the

actor shall be listed in the product's DICOM Conformance Statement. The IHE Integration Statement (see Appendix D) shall reference the DICOM Conformance Statement but does not repeat the list of DICOM SOP Classes that are considered to contain Evidence Documents. Examples of DICOM SOP Classes that may contain evidence are listed in RAD TF-3: 4.43, Table 4.43-1 and Table 4.43-2.

14.3 Evidence Document Process Flow

3315 Evidence Documents belong to the family of Evidence Objects that also includes Images, Presentation States, and Key Image Notes. These are objects generated as a result of performing procedure steps on systems in a clinical department.

3320 The start and completion of creating Evidence Documents is reported in the Scheduled Workflow Profile by the Evidence Creator using Creator Procedure Step In-Progress/Completed transactions, or by the Acquisition Modality using the Modality Procedure Step In-Progress/Completed; and in the Post-Processing Workflow by the Evidence Creator using the Workitem Procedure Step In-Progress/Completed transactions.

3325 As with other Evidence Objects, Evidence Documents are usually created by the system operator, and used by the reading physician in the process of creating a Diagnostic Report, either by reviewing or interpreting the Evidence Document contents, or by copying selected parts into the Report. Evidence Documents represent the uninterpreted information that is primarily managed and used inside an imaging department, although distribution outside the imaging department is not precluded. In contrast, the diagnostic reports described in the Simple Image and Numeric Reports Profile represent the interpreted information which is the primary output of
3330 the imaging department and are available for wide distribution.

Due to the difference between the way the Evidence Creator reports status in the Scheduled Workflow Profile (using a Creator Procedure Step transaction to the Performed Procedure Step Manager) and the way the Evidence Creator reports status in the Post-Processing Workflow Profile (using a Workitem PPS transaction to the Post-Processing Workflow Manager), two
3335 examples of the process flow will be shown below.

The scheduling part of the workflow that would typically precede the part of the workflow in the following diagram can be seen in Figure 3.2-1 (Administrative Process Flow) in the Scheduled Workflow Profile.

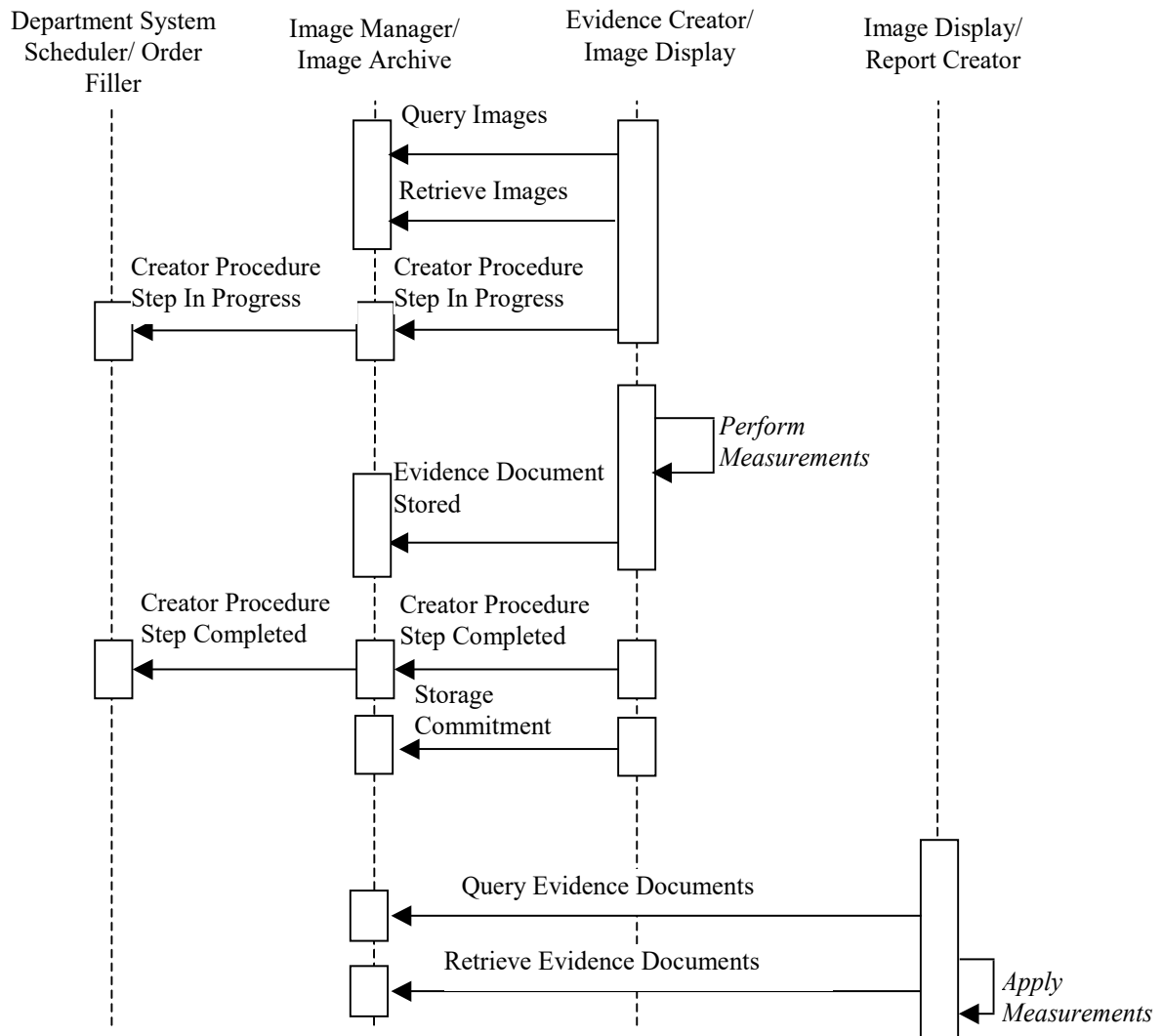

3340

Figure 14.3-1: Evidence Document Management In Scheduled Workflow

Note that the Procedure Step transactions and the Query/ Retrieve Images transactions in the above diagram are not part of the Evidence Documents Profile.

The scheduling part of the workflow that would typically precede the part of the workflow in the following diagram can be seen in Figure 12.3-1. (Post-Processing Manager Grouped with Department System Scheduler) in the Post-Processing Workflow Profile.

3345

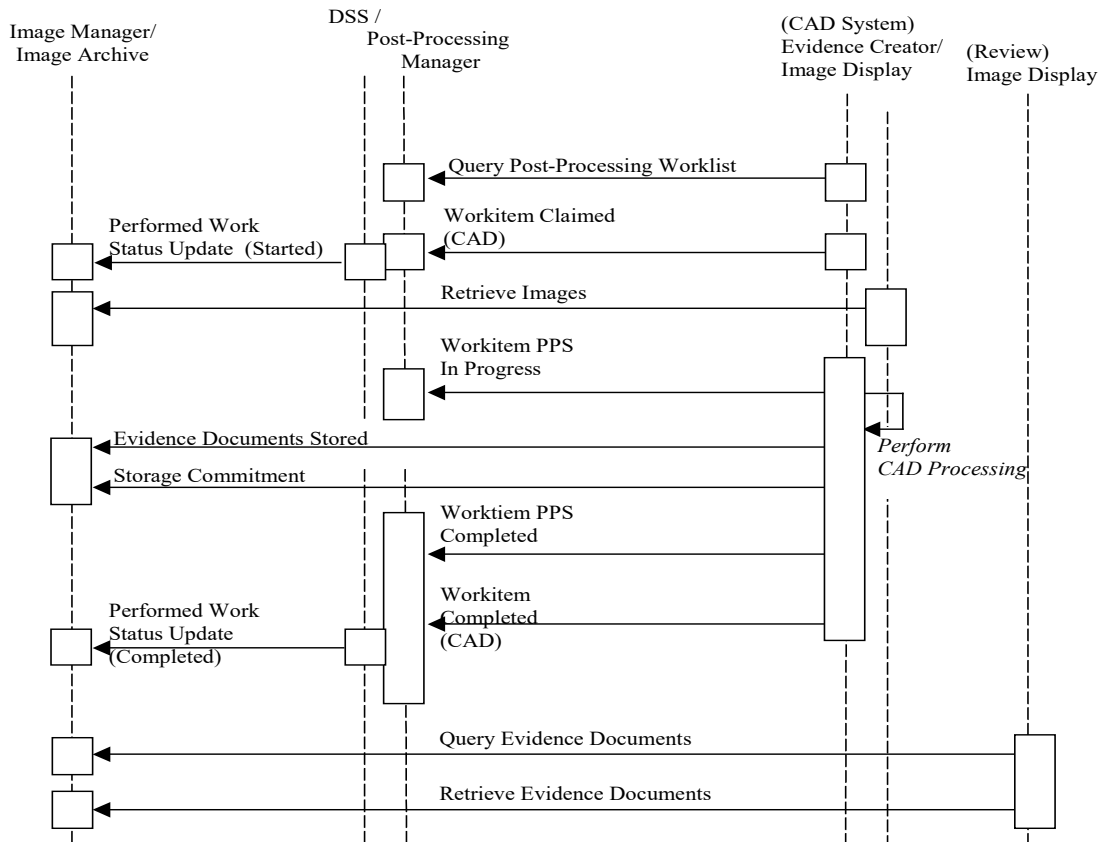

Figure 14.3-2: Evidence Document Management In Post-Processing Workflow

3350 Note that the Worklist and Workitem transactions in the above diagram are not part of the Evidence Documents Profile.

15 Portable Data for Imaging Integration Profile (PDI)

3355 The **Portable Data for Imaging Integration Profile** specifies actors and transactions that provide for the interchange of imaging-related information on interchange media. The intent of this profile is to provide reliable interchange of image data and diagnostic reports for import, display or print by a receiving actor.

This profile addresses identification of the media content's source and the patient (where appropriate), reconciliation of data during import, and the structure of the media contents.

The central elements of the profile are:

- Reliable interchange of imaging-related information based on the DICOM standard
- 3360 • A Web Content Option which provides guidelines for including web-viewable content on media
- DVD and USB Media Options

The Web Content Option addresses the case of media containing both DICOM-encoded objects and objects in XHTML or JPEG derived from these DICOM-encoded objects.

3365 **15.1 Actors/ Transactions**

Figure 15.1-1 diagrams the actors directly involved in this profile and the transactions between actors.

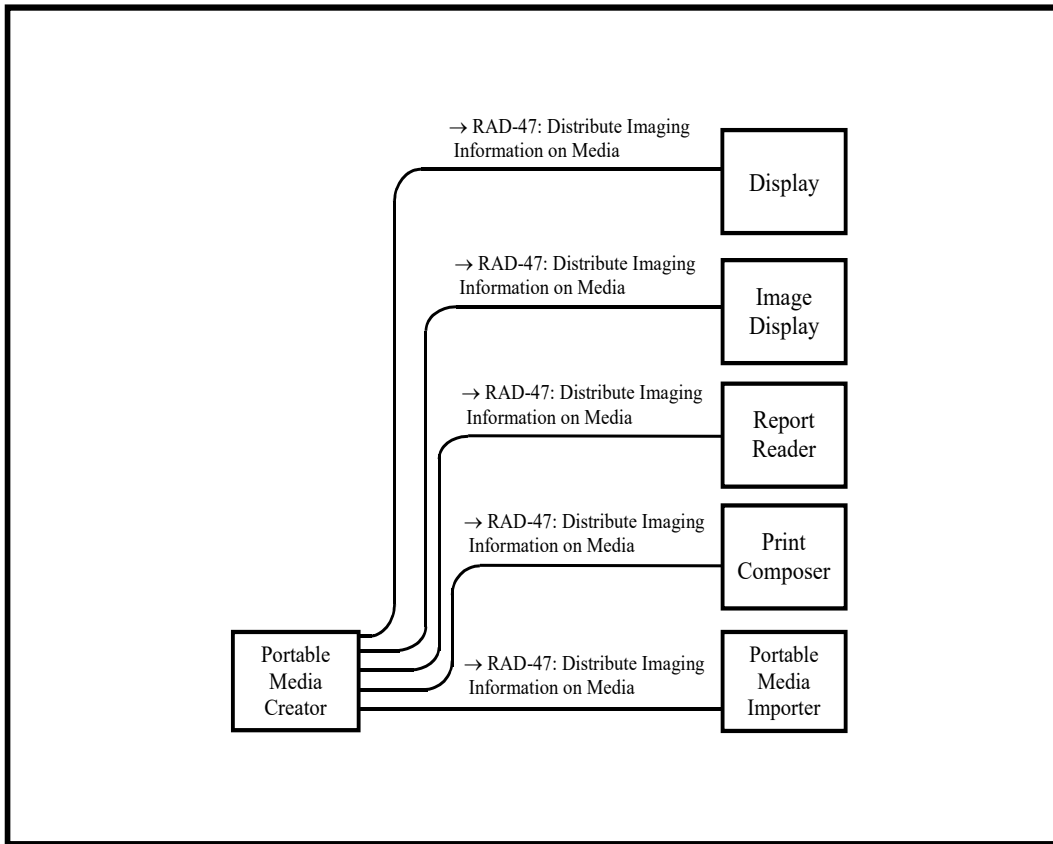

Figure 15.1-1: Portable Data for Imaging Diagram

3370 Table 15.1-1 lists the transactions for each actor directly involved in the Portable Data for Imaging Profile. In order to claim support of this integration profile, an implementation shall perform the required transactions (labeled “R”). Transactions labeled “O” are optional. A complete list of options defined by this integration profile is listed in Section 15.2. Note that one of a number of actors must be grouped with Portable Media Importer as described in Section 2.5.

3375 **Table 15.1-1: Portable Data for Imaging Integration Profile - Actors and Transactions**

Actors	Transactions	Optionality	TF Reference
Portable Media Creator	Distribute Imaging Information on Media [RAD-47]	R	RAD TF-3: 4.47
Portable Media Importer	Distribute Imaging Information on Media [RAD-47]	R	RAD TF-3: 4.47
Image Display	Distribute Imaging Information on Media [RAD-47]	R	RAD TF-3: 4.47
Report Reader	Distribute Imaging Information on Media [RAD-47]	R	RAD TF-3: 4.47
Print Composer	Distribute Imaging Information on Media [RAD-47]	R	RAD TF-3: 4.47

Actors	Transactions	Optionality	TF Reference
Display (ITI TF)	Distribute Imaging Information on Media [RAD-47]	R	RAD TF-3: 4.47

15.2 Portable Data for Imaging Integration Profile Options

Options that may be selected for this integration profile are listed in Table 15.2-1 along with the actors to which they apply. Dependencies between options when applicable are specified in notes.

3380

Table 15.2-1: Portable Data for Imaging - Actors and Options

Actor	Options	TF Reference
Portable Media Creator	Web Content	RAD TF-1: 15.4.2 RAD TF-3: 4.47.4.1.2
	DVD Media	RAD TF-1: 15.4.4 RAD TF-3: 4.47.4.1.4.1
	USB Media	RAD TF-1: 15.4.4 RAD TF-3: 4.47.4.1.4.2
Portable Media Importer	DVD Media	RAD TF-1: 15.4.4 RAD TF-3: 4.47.4.1.4.1
	USB Media	RAD TF-1: 15.4.4 RAD TF-3: 4.47.4.1.4.2
Image Display	DVD Media	RAD TF-1: 15.4.4 RAD TF-3: 4.47.4.1.4.1
	USB Media	RAD TF-1: 15.4.4 RAD TF-3: 4.47.4.1.4.2
Report Reader	DVD Media	RAD TF-1: 15.4.4 RAD TF-3: 4.47.4.1.4.1
	USB Media	RAD TF-1: 15.4.4 RAD TF-3: 4.47.4.1.4.2
Print Composer	DVD Media	RAD TF-1: 15.4.4 RAD TF-3: 4.47.4.1.4.1
	USB Media	RAD TF-1: 15.4.4 RAD TF-3: 4.47.4.1.4.2
Display	<i>No options defined</i>	-

15.3 Portable Data for Imaging Process Flow

This section describes the typical process flow related to the use of Interchange Media. The transaction covered is Distribute Imaging Information on Media [RAD-47].

3385

The following steps can be identified in this process flow:

- 3390 • The source actor (Portable Media Creator) writes a group of image dataset(s) and/or the associated diagnostic report(s) onto a piece of interchange media. It is presumed that the Portable Media Creator has access to the data from a grouped actor, or another source outside the scope of IHE.
- 3395 • The media is physically transported to a destination where the imaging-related information contained on the media will be used.
- 3400 • The Portable Media Importer reads DICOM objects (images, presentation states, key image notes, evidence documents and reports) on the media and imports them into the local information space. The Portable Media Importer reconciles the data as needed (e.g., to change the recorded Patient ID to the local Patient ID). If some classes of DICOM objects are present on the media and cannot be imported, the Portable Media Importer notifies the operator of the studies and series affected and makes clear that they are not supported by the importing application.
- 3400 • The Image Display, Report Reader, Display or Print Composer reads the objects it supports and renders them depending on the receiver's needs. If some objects are not supported by the reading application it notifies the operator that those objects are not supported.

The potential usage scenarios of the data are described in the use cases below.

3405 **15.3.1 Use Cases**

This profile is not intended to provide an archival solution. The matter of whether or not CD, DVD or USB media are suitably robust for long-term archive is not addressed by IHE.

3410 **Use Case 1 - Patient/Referring Physician Viewing:** Diagnostic and therapeutic imaging data, such as images and reports, is received on media potentially serving multiple use cases. The patient or the referring physician can view the data, either with a viewer application residing on the same media or using a web browser. For security and privacy reasons, media given to a patient would not contain data of other patients. Refer to Section 15.5 for additional security considerations.

3415 **Use Case 2 - Healthcare Enterprise Interchange:** One or more patients' data, such as images, reports or complete studies, is received on media to enable a diagnostic or therapeutic care process. Media data are imported at a different site, generally for the purpose of a "second read import" or "reference import".

- 3420 • **Second Read Import:** Media data is imported to the Image Manager/Archive to be read/over read. In order to avoid data conflicts, key patient/study attributes may need to be reconciled with existing local data. Images and related presentation states can be sent to a Print Composer to be printed.
- 3425 • **Reference Import:** Media data is imported to the Image Manager/Archive and/or Report Repository to become part of the patient history. It may be used as "relevant prior" data for future reads. In order to avoid data conflicts, key patient/study attributes may need to be reconciled with existing local data.

3430 **Use Case 3 - Operating Room Viewing:** Media data is used to enable diagnostic or therapeutic processes in environments without a reliable network connection. The volume of data can be very large and may contain image data, post-processing results and reports. In the operating room, the surgical staff receives the media and reads its contents using advanced viewing capabilities, which may include manipulating or processing images.

15.3.2 Process Flow Description

The use cases can be specified in terms of three media-related activities:

- Media Export
- Media Viewing
- 3435 • Media Import

Media Export (All Use Cases):

The Portable Media Creator assembles the media content (DICOM and web-viewable content) and writes it to the physical medium.

The following sequence of activities will be performed during media creation:

- 3440 • Export of DICOM data (FSC activity).
- Optionally, export of web-viewable data, which involves deriving easily accessible informative data from the DICOM data (Web Content Option).
- Optionally, inclusion of additional content (e.g., a DICOM Viewer or viewing software components on the media to access DICOM data).

3445 **B) Media Viewing:**

B1) Web (Use Case 1) (care providers, other users and patients without DICOM viewing equipment or software):

3450 Any web-viewable media content is received and displayed by a Display Actor, which exists as a generally available resource (i.e., web browser). Note that the Portable Media Creator cannot rely on the presence of web-viewable content on all media since it will be included only on media created using the Web Content Option).

B2) DICOM (Use Case 1 and 3) (users with DICOM viewing equipment or software):

3455 The DICOM portion of the media content is displayed using specialized applications pre-existing in the reading environment or included on the media itself. The variety of DICOM objects that an Image Display and/or Report Reader Actor can process is indicated by its support of the corresponding content profiles. The Print Composer Actor sends images from the media to a Print Server for printing.

C) Media Import (Use Case 2):

3460 The “Media Import” activity is accomplished by a Portable Media Importer and deals exclusively with the DICOM portion of the media content. The Portable Media Importer Actor is

grouped with one or more content actors (Evidence Creator, Report Creator, etc.), depending on the type of media content to be imported. The grouped actor provides storage capability for the media data accessed by the Portable Media Importer.

3465 The Portable Media Importer Actor accesses all DICOM instances referenced by the DICOMDIR file and enables the user to select a media patient dataset to be imported.

- The Portable Media Importer obtains local data that is known to be accurate within the importing institution/enterprise and reconciles “key attributes” of patient and study information (when required). A method for performing these steps is documented in the Import Reconciliation Workflow Profile (see Section 3.21). Refer to RAD TF-3: 4.47.4.1.3 for the list of “key attributes” and the related reconciliation actions to be performed.

3470 Note: The Portable Media Importer may for example be grouped with an Evidence Creator to allow the storage of its diagnostic and therapeutic imaging content to an Image Manager/Image Archive, or grouped with a Report Creator to store reports on a Report Repository. This enables use of the content for subsequent “relevant prior” data for future reads. A grouping with an Acquisition Modality Actor could also be used to allow subsequent “reads/over reads”. In the case of a Portable Media Importer grouped with the Print Composer Actor, the imported content (images and presentation states) can be sent to the Print Server to be printed.

3475

Figure 15.3.2-1 shows an example flow of events covering the use cases described in the previous sections.

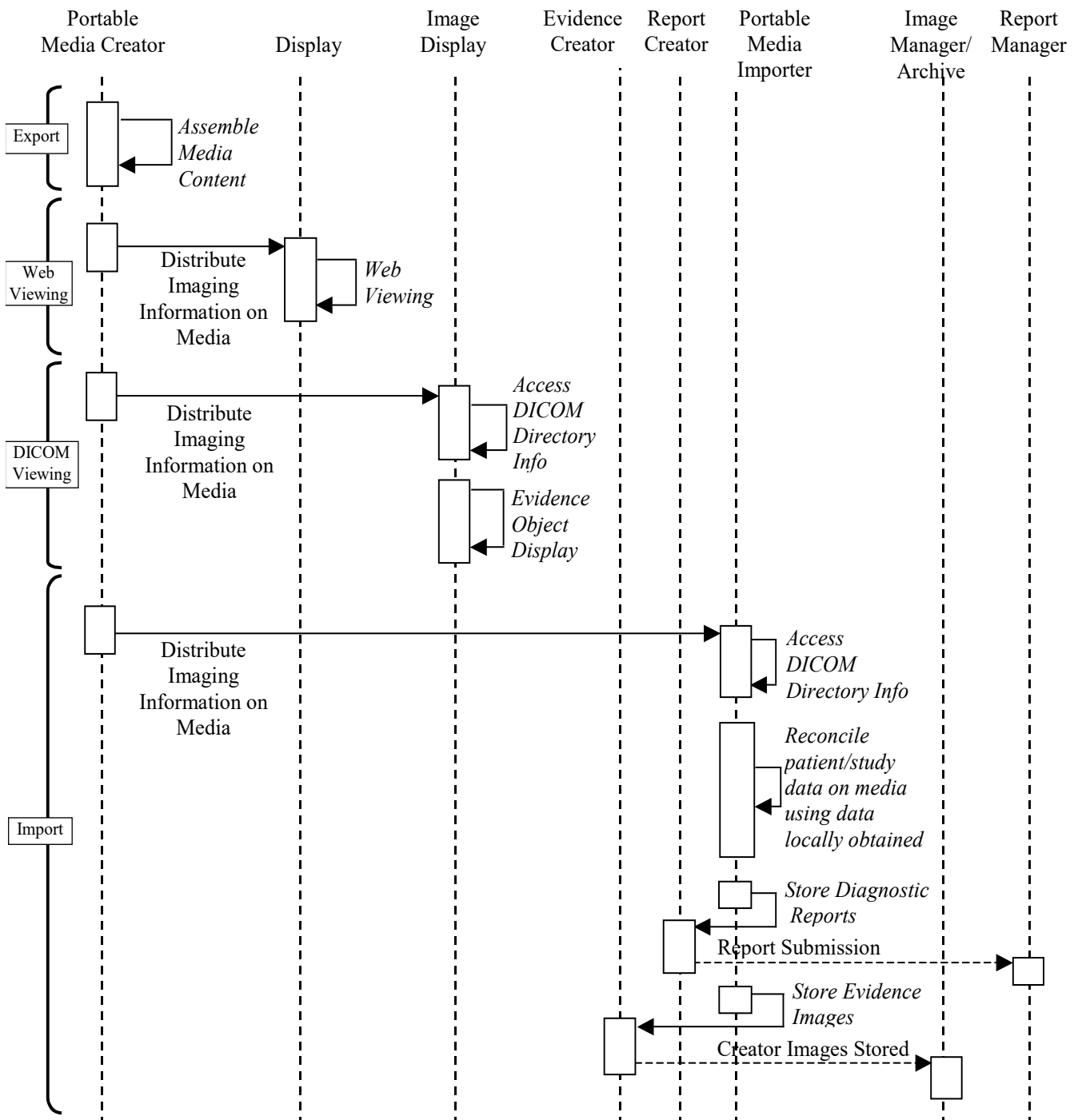

Figure 15.3.2-1: Portable Data for Imaging Process Flow

3480

15.4 Media Content

3485 The requirements on media content are intended to promote the reliable transfer of imaging data, including diagnostic reports, and to allow for the viewing of images and reports on general purpose computers.

The intent is that the media content be a “complete set of images of diagnostic quality” (a quote from a statement on the matter by the American Medical Association Expert Panel on Medical Imaging).

3490 The media content can be accessed via two "entry points" on the media: the DICOMDIR file for DICOM imaging information and optionally the INDEX.HTM file for web-viewable content. Created media are required to contain DICOM data and may optionally include web-viewable data derived from it. This web-viewable data, if present, shall faithfully preserve the clinical intent of the original DICOM information.

15.4.1 DICOM Content

3495 The DICOM data shall be created by using the DICOM Media Storage Application Profile appropriate for the content as defined in the Distribute Imaging Information on Media transaction and depending on the Options supported by the Portable Media Creator. The DICOMDIR file shall reference all DICOM files stored on the media.

3500 DICOM files shall not be placed in the root directory, but no constraints are placed on the name of directory that contains them.

15.4.2 Web Content Option

Portable Media Creators implementing the Web Content Option may also include web-viewable data on the media.

3505 The web-viewable data shall be derived from the DICOM information as XHTML files and referenced JPEG images. The XHTML entry page (INDEX.HTM) shall allow access to all of this data. This enables end-users to access relevant media content using a generally available web browser. The INDEX.HTM file shall be placed in the root directory.

3510 Note that the web-viewable data specified in this integration profile reflects the full set of the exported DICOM data or a subset considered at the time of creation to faithfully represent the patient's clinical condition. For example, if a DICOM Structured Report references only Key Images and a larger DICOM dataset, the web-viewable data derived from it may selectively include the report in XHTML format and only JPEG images derived from the DICOM Key Images.

15.4.3 Other Content

3515 Viewing applications (for example a DICOM Media Viewer) may optionally be included on the media. Such viewers may have launch links included in the HTML. Including such viewers on the media is discouraged due to security issues discussed in the next section, as well as potential interoperability problems.

3520 Additional data (e.g., a diagnostic report in non-DICOM format) may be also included on the media. Since the format of any such data is not specified by this profile, such data shall be placed in a separate directory on the media. If such data is referenced in the INDEX.HTM file, it shall be clearly indicated that this content was not generated in conformance with the IHE Radiology Technical Framework, and its reliable import has not been addressed.

15.4.4 Media Type (CD, DVD and USB)

3525 The baseline media type is CD with uncompressed images.

Named options for support of compressed images (using JPEG lossy and lossless and JPEG 2000 reversible and irreversible) on DVD and USB media are defined.

3530 Compressed images on CD, such as are commonly used for cardiac angiography and for cine ultrasound, are supported through the use of the DVD Media Option, which allows for CD as a media type that can be read by DVD drives.

15.5 Security and Privacy Aspects

Portable Media Creator Actors shall make a reasonable effort to ensure that no malicious software (viruses, etc.) is present on created media.

3535 The automatic launch of applications from media poses a risk that malicious software could be started and it is recommended that media reading actors not allow automatic launching. Portable Media Creators should therefore also avoid using automatic launching. This includes not automatically launching a DICOM media viewer that may be present on the media.

Furthermore, if a DICOM media viewer is present, security issues at the receiving actor are minimized by:

- 3540
- working under normal (restricted) user privileges and not requiring the user to work with administrator or root privileges and
 - not needing software installed on the computer where the media is used.

3545 Audit trails to track export/import/viewing activities are addressed in ITI TF-2: 3.20 and RAD TF-3: 5.1. Portable Media Creator and media reading actors that claim support of the Audit Trail and Node Authentication Integration Profile shall generate such audit trail entries.

3550 Encryption of data and other access controls to media content are not addressed in this profile. Media created using this profile should be considered to be unlocked information (e.g., like paper records). Such media should be handled according to appropriate site policies (e.g., do not give a patient a disk containing data from other patients, do not leave disks where they can be taken by unauthorized persons, etc.).

For many Use Cases it is not appropriate to place data from multiple patients on a single volume of media for security and privacy reasons.

3555 It is not good practice to include on media, either in the physical label, in the DICOMDIR or DICOM instances, the Web Content or any other content, such sensitive information as the patient's address, telephone number or national identifier (such as a US Social Security

Number), which might be used for unauthorized purposes such as identity theft or fraud. Though it is not a requirement of this profile to require the Portable Media Creator to remove any such information from any DICOM instances received prior to encoding on media, it is strongly recommended.

3560 **15.6 PDI Cross Profile Considerations**

15.6.1 ITI Cross-Enterprise Document Media Interchange (XDM)

3565 A Portable Media Creator in PDI might be grouped with a Portable Media Creator in the XDM Profile (IHE ITI TF) to enable it to include DICOM instances on the same media as XDM content (see RAD TF-3: 4.47.4.1.2.2.3). To link the DICOM instances with the XDM metadata, a KOS instance should be used. This instance can be e.g., provided by an existing XDS-I infrastructure.

A Portable Media Importer in PDI might be grouped with a Portable Media Importer in the XDM Profile to process the combined PDI / XDM media, e.g., for the use in an XDS-I infrastructure (see RAD TF-3: 4.47.4.1.3.4).

3570 **16 NM Image Integration Profile**

The NM Image Profile specifies how NM Images are to be stored by Acquisition Modalities and Evidence Creator workstations and how Image Displays should retrieve and make use of them.

It defines the basic display capabilities Image Displays are expected to provide, (such as might be sufficient for a referring physician) but does not address advanced review features.

3575 It also defines how result screens, both static and dynamic, such as those created by NM Cardiac Processing Packages, should be stored using DICOM objects that can be displayed on general purpose Image Display systems.

3580 Note that the NM Image Profile is undergoing revision, and vendors considering implementation are advised to include the modifications contained in the trial implementation version “NM Image Profile with Cardiac Option”. For additional information please contact the IHE Radiology Technical Committee at ihe-rad-tech@googlegroups.com.

The NM Image Profile can be enhanced by combining it with workflow profiles such as Scheduled Workflow, Post-Processing Workflow and Reporting Workflow which address how to schedule, manage and report the status of the steps in which NM Image objects are created.

3585 **16.1 Actors/ Transactions**

Figure 16.1-1 shows the actors directly involved in the NM Image Integration Profile and the relevant transactions between them. Other actors that may be indirectly involved due to their participation in the Scheduled Workflow Profile, the Post-Processing Workflow Profile, etc. are not necessarily shown.

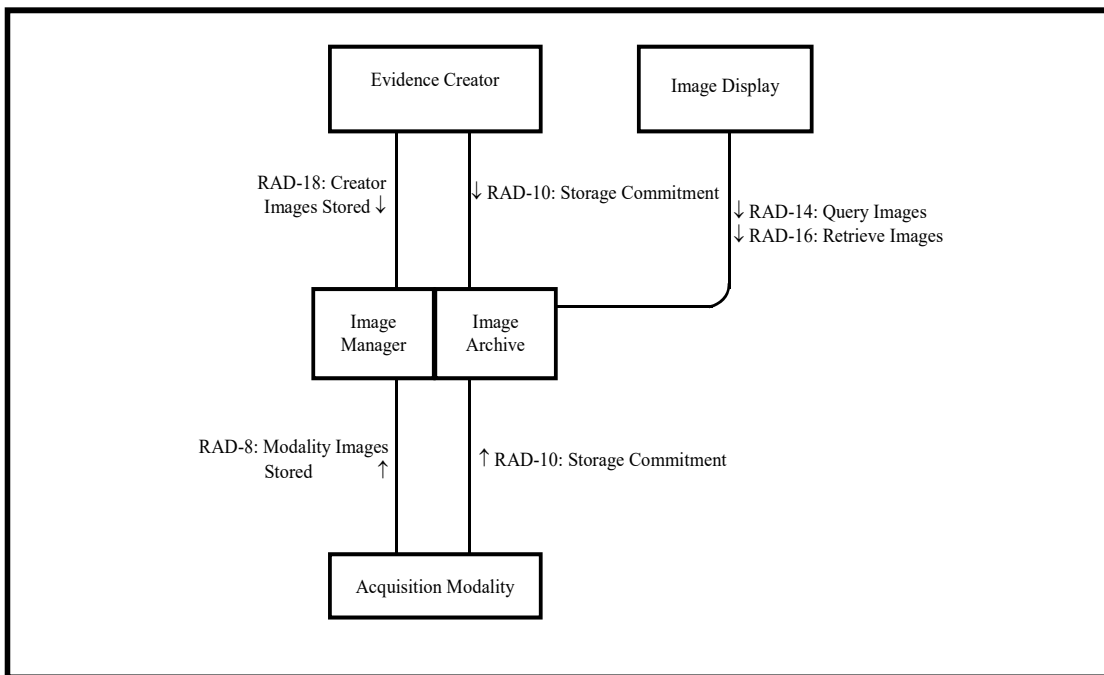

3590

Figure 16.1-1: NM Image Actor Diagram

Table 16.1-1 lists the transactions for each actor directly involved in the NM Image Profile. In order to claim support of this integration profile, an implementation must perform the required transactions (labeled “R”). Transactions labeled “O” are optional.

3595 A complete list of named options defined by this integration profile and that implementations may choose to support is listed below in Section 16.2.

Table 16.1-1: NM Image Integration Profile - Actors and Transactions

Actors	Transactions	Optionality	TF Reference
Acquisition Modality	Modality Images Stored [RAD-8]	R	RAD TF-2: 4.8
	Storage Commitment [RAD-10]	R	RAD TF-2: 4.10
Evidence Creator	Creator Images Stored [RAD-18]	R	RAD TF-2: 4.18
	Storage Commitment [RAD-10]	R	RAD TF-2: 4.10
Image Manager/Archive	Modality Images Stored [RAD-8]	R	RAD TF-2: 4.8
	Creator Images Stored [RAD-18]	R	RAD TF-2: 4.18
	Storage Commitment [RAD-10]	R	RAD TF-2: 4.10
	Query Images [RAD-14]	R	RAD TF-2: 4.14
	Retrieve Images [RAD-16]	R	RAD TF-2: 4.16
Image Display	Query Images [RAD-14]	R	RAD TF-2: 4.14
	Retrieve Images [RAD-16]	R	RAD TF-2: 4.16

To participate as an evidence creator in Nuclear Medicine, the system must create derivative data from original NM modality image data. Examples of such derivative data include:

- 3600 a) Reconstruction, reorientation, filtering, or other processing of NM data, with output of NM modality image objects.
- b) Quantization of NM data, with the display and storage of result screens as SC or MFSC image objects.
- c) Registration between an NM data set and another data set.

3605 For all NM modality objects created, the evidence creator must meet the requirements of an acquisition modality with respect to encoding, storage, and inclusion of required DICOM tags, as noted in RAD TF-2: 4.8.4.1.2.2.

3610 If the system creates SC or MFSC objects, the evidence creator is encouraged to support the Result Screen Export Option, and conform to the requirements of this option for any stored result screens.

16.2 NM Image Integration Profile Options

Options that may be selected for this integration profile are listed in the Table 16.2-1 along with the Actors to which they apply. Dependencies between options when applicable are specified in notes.

3615

Table 16.2-1: NM Image - Actors and Options

Actor	Options	TF Reference
Acquisition Modality	<i>No options defined</i>	--
Evidence Creator	Result Screen Export Option	RAD TF-2: 4.18.4.1.2.4 RAD TF-2: 4.16.4.2.2.4
Image Archive/Manager	<i>No options defined</i>	--
Image Display	Review Option	RAD TF-2: 4.16.4.2.2.2.5

3620

The NM Image Profile is designed to provide faithful and complete storage and retrieval of NM data and sufficient display functionality to allow adequate review of nuclear medicine images by referring physicians. It should also be sufficient for secondary review (without reprocessing capability) of cardiac nuclear medicine studies by cardiologists and for correlation of nuclear medicine images with other imaging modalities during review by general radiologists.

The Review Option is intended to add functionality for primary (non-cardiac) NM interpretation.

The Result Screen Export Option adds functionality for storing Result Screens (which may be static or may contain moving components) in commonly displayable DICOM formats.

3625

Acquisition Modality Actors which support Result Screen Export should claim the appropriate options as an Evidence Creator.

Processing functions of both cardiac and non-cardiac data are not addressed in this profile, and should be performed on a dedicated NM workstation.

16.3 NM Image Process Flow

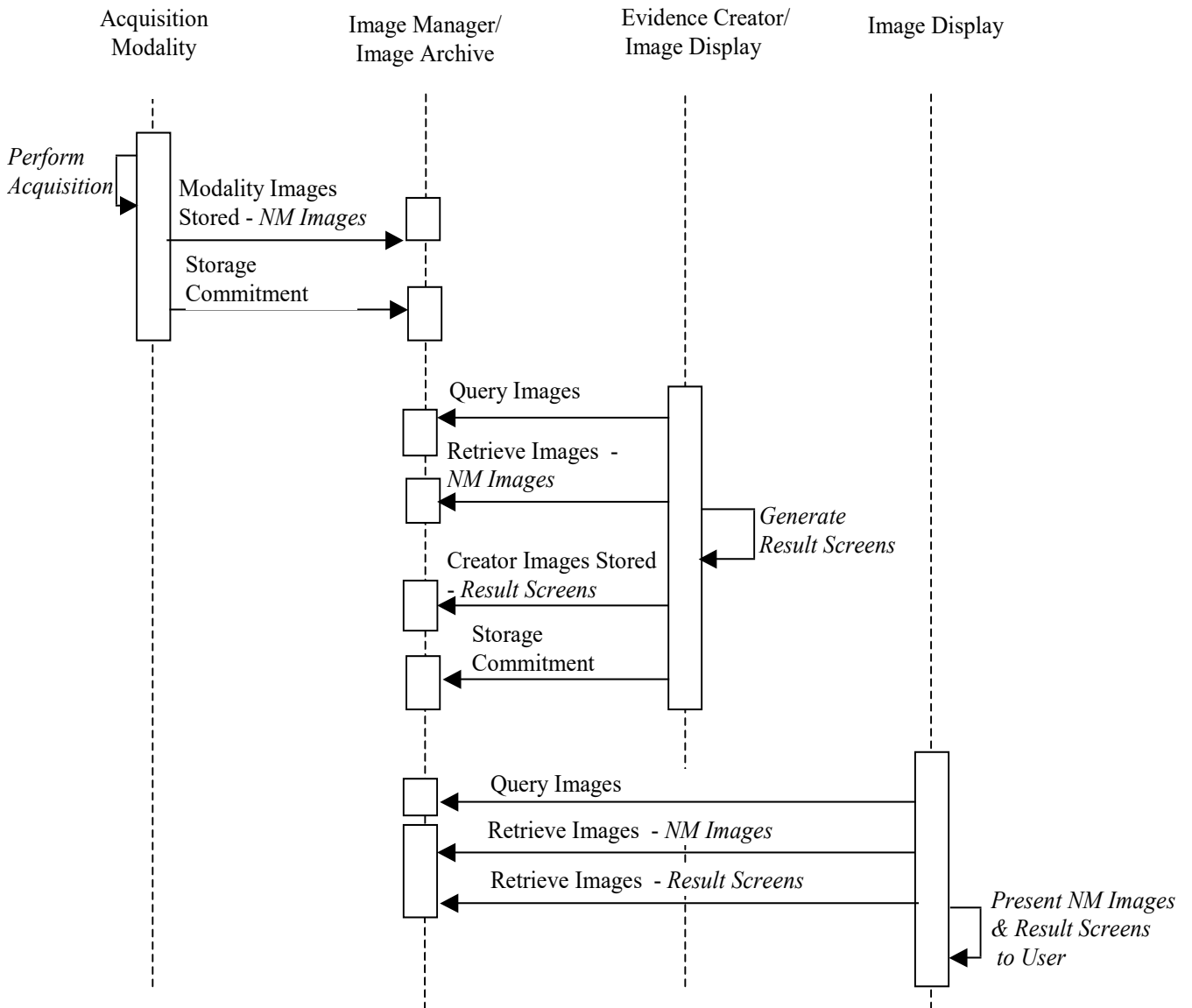

3630

Figure 16.3-1: NM Image Process Flow

3635

The process of creating, storing and using NM Image content can be managed in much the same way as other image content using the Scheduled Workflow and Post-Processing Workflow Profiles. Examples of NM Workflow and Guidelines for carrying it out using the two mentioned Workflow Profiles can be found in Appendix E: Nuclear Medicine.

17 Teaching File and Clinical Trial Export (TCE)

3640 This profile defines a means of selecting the relevant images, key image notes, reports, evidence documents and presentation states on the Export Selector (which would typically be grouped with an Acquisition Modality, Image Display, Evidence Creator or Report Creator), a means to enter additional information at that time, a means of transfer to an Export Manager Actor whose behavior is defined, and a means of transfer to a Receiver Actor whose behavior is not defined (but which might be a teaching file authoring or distribution system, clinical trial image management system, or a publication authoring system or might be grouped with an Image Manager/Archive or Portable Media Creator).

3645 17.1 Actors/Transactions

3650 Figure 17.1-1 shows the actors directly involved in the Teaching File and Clinical Trial Export Integration Profile and the relevant transactions between them. Other actors that may be indirectly involved due to their participation in Key Image Note, Consistent Presentation of Images, Evidence Document, Simple Image and Numeric Report and Portable Data for Imaging Profiles, etc. are not shown.

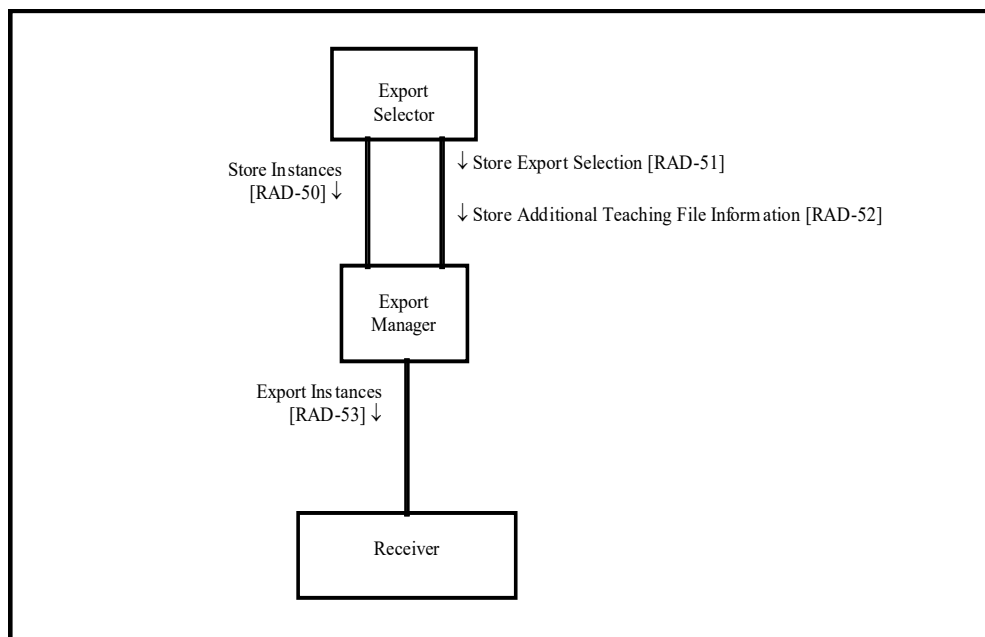

Figure 17.1-1: Teaching File and Clinical Trial Export Actor Diagram

3655 Table 17.1-1 lists the transactions for each actor directly involved in the Teaching File and Clinical Trial Export Profile. In order to claim support of this integration profile, an implementation must perform the required transactions (labeled “R”). Transactions labeled “O” are optional. A complete list of options defined by this integration profile and that implementations may choose to support is listed in Section 17.2.

3660

Table 17.1-1: Teaching File and Clinical Trial Export Integration Profile - Actors and Transactions

Actors	Transactions	Optionality	TF Reference
Export Selector	Store Instances [RAD-50]	R (see Note)	RAD TF-3: 4.50
	Store Export Selection [RAD-51]	R	RAD TF-3: 4.51
	Store Additional Teaching File Information [RAD-52]	O	RAD TF-3: 4.52
Export Manager	Store Instances [RAD-50]	R (see Note)	RAD TF-3: 4.50
	Store Export Selection [RAD-51]	R	RAD TF-3: 4.51
	Store Additional Teaching File Information [RAD-52]	R	RAD TF-3: 4.52
	Export Instances [RAD-53]	R	RAD TF-3: 4.53
Receiver	Export Instances [RAD-53]	R	RAD TF-3: 4.53

Note: If the Export Manager is grouped with an Image Manager/Archive, there is no need for Store Instances [RAD-50] transactions between the Export Selector and the Export Manager as long as the instances are already available to the Export Manager.

3665

17.2 Teaching File and Clinical Trial Export Integration Profile Options

Options that may be selected for this integration profile are listed in the Table 17.2-1 along with the actors to which they apply. Dependencies between options when applicable are specified in notes.

Table 17.2-1: Teaching File and Clinical Trial Export - Actors and Options

Actor	Options	TF Reference
Export Selector	Additional Teaching File Information	RAD TF-1: 17.2.3 RAD TF-3: 4.52
	Delay for Reason	RAD TF-1: 17.2.4 RAD TF-3: 4.51.4.1.5
Export Manager	De-identify Pixel Data	RAD TF-1: 17.2.1 RAD TF-3: 4.51.4.1.4.4
	Remap Identifiers	RAD TF-1: 17.2.2 RAD TF-3: 4.51.4.1.4.3
	Additional Teaching File Information	RAD TF-1: 17.2.3 RAD TF-3: 4.52
	Delay for Reason	RAD TF-1: 17.2.4 RAD TF-3: 4.51.4.1.5
Receiver	Additional Teaching File Information	RAD TF-1: 17.2.3 RAD TF-3: 4.53

3670

17.2.1 De-identify Pixel Data Option

3675 In the default case, the Export Manager is responsible for de-identifying instances by removing the necessary DICOM attributes or replacing them with alternative identification values (pseudonymization), without invalidating the IOD. This operation would normally be fully automated, usually according to some pre-configured set of rules.

If identification is burned in to the pixel data; however, as is commonly the case with Ultrasound and Secondary Capture images, it is difficult to remove this automatically. Accordingly, a human operator would use an appropriate user interface to “black out” offending areas of text.

3680 This named option requires that the capability to remove the offending information be present, and that images shall not be forwarded as de-identified and pseudonymized until it has been confirmed that burned in identification is no longer present.

3685 The option does not specify constraints on how this capability might be implemented, either in terms of workflow, such as providing an internally managed work list for operators or user interface features, such as the size, shape and number of graphic operations needed for editing the pixels.

17.2.2 Remap Identifiers Option

3690 For teaching file applications, it is rarely necessary to exercise much control over the identifiers that are generated and used to replace the patient identifiers. As long as valid and globally unique UIDs are generated, and other identifiers are replaced with values that do not invalidate the IOD, they may be sequential or arbitrary or random.

For clinical trial applications this may be sufficient as long as the receiving site is informed of the new arbitrary identifiers and to which trial subject they correspond through some out of band mechanism, such as a data transmittal form.

3695 However, clinical trial workflow is greatly enhanced if the subject enrollment list is used to remap the patient’s actual identifiers to the trial subject identifiers, and additional clinical trial attributes are inserted into the header. Provision of such a capability is the “remap identifiers option”.

3700 Further, in some protocols, the list of expected studies and their mapping to pre-defined time points is known in advance, and the remapping capability could take advantage of this knowledge, if available.

This named option requires that such a remapping capability be present.

3705 The option does not specify constraints on how this capability might be implemented, either in terms of configuration, such as providing a user interface or preloading capability for the subject enrollment list or remapping table, or sophistication, such as providing rule-driven generation of UID and text values at either the patient or the study level.

This option does require that at minimum specific attributes be added or remapped; see the description of the Store Export Selection [RAD-51] transaction in RAD TF-3: 4.51.4.1.4.3.

17.2.3 Additional Teaching File Information Option

3710 The manifest of instances to be exported (the Export Selection) consists of references only, with
no additional information. To allow for the user of the Export Selector to not only flag instances
for export, but also to add additional information such as text and codes, a named option is
specified that provides for the support of a specific transaction Store Additional Teaching File
Information [RAD-52]. This allows additional information to be encoded in one or more
3715 Structured Report instances that may be stored and included in the set of instances to be
exported. The Store Export Selection [RAD-51] Key Object Selection document references the
Additional Teaching File Information SR instances. Once pseudonymized, this information is
exported using the Export Instances [RAD-53] transaction just like any other instance.

17.2.4 Delay for Reason Option

3720 Images may have been selected for teaching before the final pathological diagnosis or other
information is known, yet may need to be de-identified before transfer to the authoring system,
after which additional material cannot be linked. Since such information may be important to the
integrity of the teaching file, this option defines a mechanism for the Export Manager to delay
export until the system has received the specified information, and then to forward both to the
Receiver.

3725 17.3 Implementation Issues

This profile is designed with the following implementation scenarios in mind:

Scenario 1:

3730 The Export Manager is grouped with an Image Manager/Archive. In this case, there is no need
for Store Instances [RAD-50] transactions between the Export Selector and the Export Manager,
as long as the instances are already available to the Export Manager.

Scenario 2:

The Export Manager is not grouped with an Image Manager/Archive. In this case, Store
Instances [RAD-50] transactions between the Export Selector and the Export Manager are used
to make the instances available to the Export Manager.

3735 Scenario 3:

The Receiver is grouped with a Portable Media Creator and claims support of the Portable Data
for Imaging Profile. In this case the instances and manifest received are recorded to media.

Scenario 4:

3740 The Export Manager is grouped with the Image Manager/Archive in System A. The Receiver is
grouped with an Image Manager/Archive in System B. In this case, the exported instances and
manifest are made available in System B.

17.4 Teaching File and Clinical Trial Export Integration Profile Process Flow

3745 This section describes the typical process flow related to the selection, pseudonymization and export of images, key image notes, reports, evidence documents and presentation states during the creation of a teaching file or for a clinical trial.

The transactions covered are [RAD-50] through [RAD-53].

In general, the process flow is as follows.

3750 On an Export Selector, the user selects images, key image notes, reports, evidence documents and presentation states, either as individual instances or as entire series or studies, that are relevant for a Teaching File or a Clinical Trial or some other purpose (such as use in a publication).

3755 The Export Selector is possibly grouped with an Image Display, an Acquisition Modality, an Evidence Creator and/or a Report Creator. When grouped with an appropriate Actor participating in the appropriate Profile, the device may also be capable of displaying or importing Portable Media (PDI Profile), query and retrieval of Reports (SINR Profile), Evidence Documents (ED Profile), query and retrieval of Key Image Notes (KIN Profile), and/or Presentation States (CPI Profile).

3760 The user selection results in the creation of a manifest, listing what was selected for export. This document is the Export Selection.

Optionally, the user may enter additional information during selection as text or with simple structure and codes, which is encoded and sent separately from the manifest.

3765 The instances are transferred to the Export Manager, unless the Export Manager is grouped with an Image Manager/Archive and the instances are known to already reside there (by static configuration or recollection of the application entity from which the images were received).

The additional information, if any, and the manifest, are transferred to the Export Manager.

3770 The Export Manager is capable of replacing patient identifiers with pseudonymous identifiers, possibly according to some pre-registered mapping scheme or arbitrarily, and optionally providing manual editing of the pixel data to perform de-identification, and optionally delaying the export until further information (e.g., the histopathology report) is available.

The Export Manager transfers the pseudonymized instances and manifest to a Receiver, whose further behavior is not defined (except to the extent that the Receiver may be grouped with an Image Manager/Archive or Portable Media Creator).

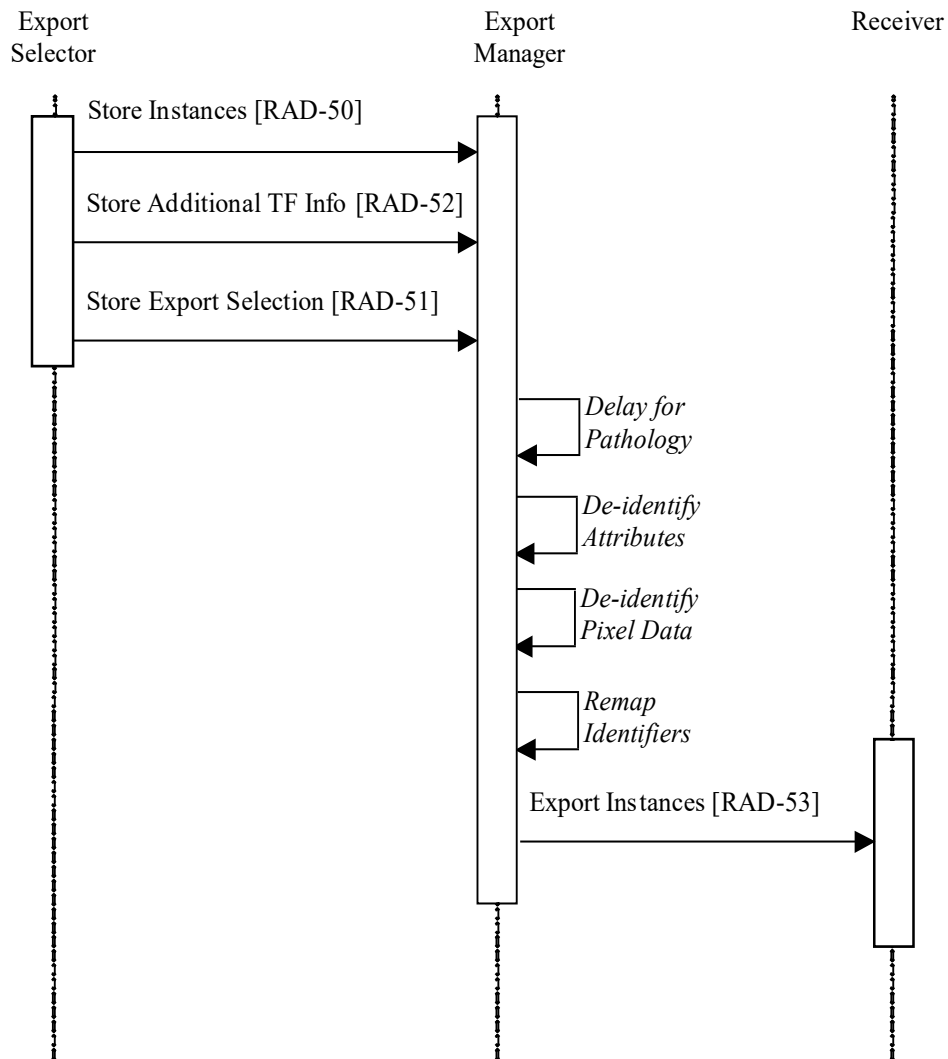

3775

Figure 17.4.1-1: Basic Process Flow in Teaching File and Clinical Trial Export Profile

Note 1: In Figure 17.4.1-1, the sequence of the [RAD-50], [RAD-51] and [RAD-52] transactions is not specified; these transactions may overlap or occur in any order.

3780

Note 2: In Figure 17.4.1-1, the [RAD-50] transaction may be omitted if the Export Manager is grouped with the Image Manager/Archive.

3785

The following use cases are not intended to be exhaustive nor in any way to constrain the manner in which the profile is implemented. Rather they illustrate a range of scenarios from simple to complex that may be satisfied with the same actors and transactions. To provide context, in some use cases, behavior is described that is outside the scope of this profile. Further, they serve to illustrate the differences and similarities between workflows for teaching files and clinical trials.

17.4.1 Teaching File Use Cases

3790 The teaching file is a vital tool in medical education. Traditionally assembled from collections of film, teaching files now need to be constructed from digital images. Digital media enables broader dissemination of the content both within and outside the enterprise, often as federated collections that share a common query mechanism.

3795 Teaching file case authors need access to images and related information, which usually reside in the Image Archive/Manager and are viewed on an Image Display. Cases may also be identified on the Acquisition Modality. Relevant images, series or studies are often identified whilst the author is engaged in other tasks such interpretation; hence need to be flagged for later authoring.

Enterprises frequently restrict access to information containing a patient's identity on systems on which teaching files are typically authored; hence the images and related information may need to be de-identified before transfer to the authoring system. Distribution of teaching files beyond an institution always involves de-identification.

3800 17.4.1.1 Use Case 1 – Images Selected for Teaching File During Reporting, Review or Acquisition

User Actions:

3805 A radiologist is performing diagnostic reporting of possibly many studies for different patients during the course of the day. Alternatively, the radiologist is consulting on a study received from a referral patient on CD. Or, the radiologist is performing an image-guided biopsy on an acquisition device.

3810 Images from a particular patient are noted to be of special interest and potentially suitable for teaching. The radiologist selects several relevant images from the current and prior studies to be de-identified and saved to his teaching file collection. The selection may entail entire series or studies, such as when later 3D reconstruction or multi-modality fusion may be required. No additional information is entered at this time since the radiologist is busy.

Sometime later, the radiologist will access his teaching file collection and use a teaching file authoring program on his personal computer to create a multi-media teaching file. The manner in which the teaching file is authored and distributed is beyond the scope of this profile.

3815 The transfer to the radiologist's teaching file collection may take place either over the network or on media (the latter case might be applicable if the radiologist is a locum or from an outside facility or if the clinical and teaching networks are not connected).

Implementation:

3820 The radiologist is viewing images on an Image Display grouped with an Export Selector. The Image Display is also participating in the Portable Data for Imaging Profile in the case of the review of the referral CD. Or, the radiologist is working on an Acquisition Modality grouped with an Export Selector.

The Export Selector allows one or more images from current and prior studies to be selected, and then to be "exported for teaching".

- 3825 The Export Selector may be preconfigured to know that the images are already stored on an Image Manager/Archive with which the Export Manager is grouped; in such a case no Store Instances [RAD-50] transactions are required. In the media case, Store Instances [RAD-50] transactions would be required.
- The user action triggers a Store Export Selection [RAD-51] transaction to the Export Manager.
- 3830 The manifest is encoded as a Key Object Selection document with a Document Title of “For Teaching File Export”. When entire series or studies have been selected, the manifest will enumerate all the instances from all the selected series and studies.
- There may be multiple different teaching file “folders” to which the case might be added. To allow the user to identify which teaching file the images are intended for, a free text field or a pre-configured pull-down list is provided, which is encoded as the disposition in the text value of the Key Object Selection document.
- 3835 No additional content was entered at the time of selection, so no Store Additional Teaching File Information [RAD-52] transaction is sent.
- If the Export Manager is not grouped with an Image Manager/Archive that already has the images, upon receiving the images via the Store Instances [RAD-50] transaction, the Export Manager stores them internally.
- 3840 When the Export Manager receives the Store Export Selection [RAD-51] transaction, and all the images referenced therein are available, the collection is queued for pseudonymization and export.
- 3845 The Export Manager automatically removes all patient identification from the image attributes as well as other text and private attributes (according to a pre-configured set of rules), checks to be sure that the SOP Class of the image is not one likely to contain burned-in identification in the pixel data, and inserts new dummy patient identification and other text attributes so as not to invalidate compliance of the instance with the IOD. Note that the extent of de-identification is configurable, and if de-identification is to be performed in the teaching file authoring system later, may not be performed by the Export Manager at all. This may be the case when the patient’s identity is required by teaching file authoring system to allow the user to search for other clinical and historical information.
- 3850 If the Export Manager supports the De-identify Pixel Data Option, any of the images likely to contain burned in identification information in the pixel data are placed on an internal work list for a human operator to check and if necessary edit the pixel data to remove the burned in identification, before the images are forwarded to the Receiver.
- 3855 The Export Manager then sends the pseudonymized DICOM images and an updated Key Object Selection document containing the manifest referencing the new identifiers and UIDs to the appropriate Receiver using an Export Instances [RAD-53] transaction.
- 3860 The Receiver may be the enterprise’s central teaching file authoring system. Upon receiving the images and the manifest, it extracts the identity of the radiologist who created the manifest from the Person Observer Identifying Attribute template encoded within the Key Object Selection

3865 document. It uses this identity, or the disposition information, to route the case to that user's
folder of pending cases for authoring. The Receiver could be grouped with a Portable Media
3870 Creator, in which case the images and manifest could be burned to an IHE PDI CD. Note that the
behavior of the Receiver is described only to illustrate the use case, and is beyond the scope of
this profile.

3870 **17.4.1.2 Use Case 2 – Complete Teaching File Authoring During Reporting with Multiple Instance Types and Multiple Export Targets**

User Actions:

A radiologist is performing diagnostic reporting. Images from a particular patient are noted to be
of special interest and potentially suitable for teaching. In addition to having the clinical report
for the current case that has just been created, the radiologist has also queried for prior reports,
3875 extracted a surgical pathology report from an external report repository, and had evidence
documents previously created by a quantitative analysis package running on the acquisition
device. The radiologist selects several relevant images from the current and prior studies, saves
presentation states containing the appropriate windows and annotations of interesting lesions, as
3880 well as several evidence documents and the surgical pathology report, and decides to create a
teaching file.

The workstation then prompts the radiologist to enter additional information according to a pre-
defined template of headings and plain text sections, including history, organ system, anatomy,
findings, differential diagnosis and final diagnosis. The radiologist uses the workstation's text
3885 editing capability to cut and paste from the various reports into the template, as well as selecting
organ system, anatomy and diagnoses from pick-lists of codes.

Upon completion, the user instructs the workstation to release the case, which is then made
available throughout the enterprise on the PACS and electronic medical record systems with a
pseudonymous identification in the departmental teaching collection folder, as well as via the
web both inside and outside the enterprise.

3890 **Implementation:**

The radiologist is viewing images on an Image Display grouped with an Export Selector, as well
as an Evidence Creator, Report Creator and Report Reader. It participates in the Evidence
Document and Simple Image and Numeric Report Profiles and hence has access to Evidence
3895 Documents and Reports, as well as an External Report Repository. It is also participating in the
Consistent Presentation of Images Profile hence supports the creation and retrieval of
Presentation States. The Export Selector supports the Additional Teaching File Information
Option.

The Export Selector allows one or more images, reports, evidence documents or presentation
states from current and prior studies to be selected, and then to be “exported for teaching”,
3900 together with the additional information.

The user action triggers Store Instances [RAD-50] transactions, Store Additional Teaching File Information [RAD-52] transactions and multiple Store Export Selection [RAD-51] transactions to the Export Manager (one for each Receiver).

3905 The manifest is encoded as a Key Object Selection document. The additional information is encoded as a Structured Report according to a pre-defined template.

The Export Manager de-identifies and re-identifies the image, reports, evidence documents, presentation states and additional information with pseudonymous values as in Use Case 1.

3910 The Export Manager then sends the pseudonymized DICOM instances, the pseudonymized additional information, and an updated Key Object Selection document containing the manifest referencing the new identifiers and UIDs to the appropriate Receivers using Export Instances [RAD-53] transactions.

3915 The multiple Receivers in this use case include the Image Managers and Archives for the clinical PACS and the Electronic Medical Record Systems, as well as a Receiver that is the enterprise's own web-based teaching file distribution system, and another Receiver that is a portal to a central repository of teaching files operated by the parent academic institution.

17.4.1.3 Use Case 3 – Images Selected for Teaching File During Reporting with Delayed Export Awaiting Pathology

User Actions:

3920 A radiologist is performing diagnostic reporting. Images from a particular patient are noted to be of special interest and potentially suitable for teaching. The radiologist selects several relevant images from the current study to be de-identified and saved to his teaching file collection.

However, the teaching file case cannot be authored until the pathology report is available. Accordingly, during selection the radiologist chooses the “delay for histopathology report” modifier to the “export for teaching” action.

3925 Implementation:

The implementation proceeds as in Use Case 1.

The Key Object Selection document, in addition to having a Document Title that indicates that the case is for teaching file export, also has a coded Concept Modifier indicating “Delay for histopathology report”.

3930 When the Export Manager receives the Store Export Selection [RAD-51] transaction, and all the images referenced therein are available, the collection is queued. However, since the Export Manager supports the Delay for Reason Option, pre-configured rules within the Export Manager Actor triggered by the “Delay for Reason” modifier indicate that the device should wait until it receives a (relevant) histopathology report for the patient, before de-identifying and pseudonymizing the images and the histopathology report and forwarding them to the Receiver.

3935

The manner in which the Export Manager receives the histopathology report is undefined and outside the scope of this profile, but it must be re-encoded in a DICOM Structured Report

(perhaps as plain text) for export to the Receiver, and a reference to it included in a revised manifest.

3940 **17.4.2 Clinical Trial Use Cases**

Clinical trials have similar needs to teaching files, in that images and related information need to be selected for export to other systems, and other organizations in the case of multi-center trials. During export, images need to be de-identified and trial-specific identifiers inserted in accordance with local or national policy and the rules of the trial protocol.

3945 The following use cases serve to illustrate the differences and similarities between workflows for teaching files and clinical trials.

17.4.2.1 Use Case 4 – Series or Studies Selected for Clinical Trial from Referring User’s Workstation or Acquisition Modality

User Actions:

3950 A patient enrolled in a multi-center clinical trial undergoes an examination, the images of which require review by a central facility. Though the patient has given their informed consent to release their identification (PHI) to the central facility, site policy dictates that the images be de-identified first regardless. The managers of the trial supply replacement identifiers to be used.

3955 A technologist, nurse or physician participating in the trial uses a referring user’s workstation on the PACS to select the relevant studies, or selected series from the study, for export to the central facility.

Alternatively, the technologist performing a study uses the acquisition device to select the relevant study, or selected series from the study, for export to the central facility.

Implementation:

3960 In this case, the user is viewing images on an Image Display or Acquisition Modality grouped with an Export Selector. The Export Selector allows images, series and studies to be selected, and then to be “exported for clinical trial”.

3965 The user action triggers the Export Selector to send images and an Export Selection to the Export Manager as in Use Case 1, except that the Document Title of the Key Object Selection document specifies “For Clinical Trial Export” instead of “For Teaching File Export”, and there is no Additional Teaching File Information transaction.

3970 There may be multiple trials in progress, and a single patient may be a participant in more than one trial; hence, to allow the user to identify which clinical trial the images are intended for, a free text field or a pre-configured pull down list is provided, which is encoded as the disposition in the text value of the Key Object Selection document.

The Export Manager de-identifies and re-identifies the image, reports, evidence documents, presentation states and additional information with pseudonymous values as in Use Case 1, except that the Export Manager supports the Remap Identifiers Option. In order to pseudonymize the images with the trial-specific identifiers, both as replacements for the conventional patient

3975 identification attributes and to populate the clinical trial specific attributes, the Export Manager Actor contains a pre-configured mapping of Patient to Subject identifiers (usually referred to as a subject enrollment list). The Export Manager inserts replacement patient identification and clinical trials attributes obtained from its mapping table.

3980 The Export Manager Actor then sends the pseudonymized DICOM images and an updated manifest to a Receiver as in Use Case 1. Which Receiver to send to may be pre-configured or may vary depending on the disposition text value of the manifest.

3985 The Receiver may be the system responsible for transferring the images to the central review facility. For privacy and security considerations, typically it will use a secure Internet channel, such as a VPN, TLS (SSL) or SSH tunnel. The security mechanism is beyond the scope of this profile.

Or, the Receiver could be grouped with a Portable Media Creator, as described in Use Case 1, in which case CDs would be burned and mailed to the central review facility.

This use case is distinguished from the teaching file use cases in that:

- Selection is usually at the study or series level, and rarely at the image level
- 3990 • A mapping to pre-defined replacement identifiers is defined in the Export Manager
- The Export Manager also inserts clinical trial specific attributes
- A means of routing the images to the appropriate trial is required

In other respects, this use case is fundamentally the same as Use Case 1.

17.4.3 Research Collection Use Cases

3995 The selection of instances or entire studies for research purposes shares many similarities with use cases for teaching files and clinical trials. The studies generally remain in circulation for clinical use, as well as being “copied” into separate “folders” in the clinical Image Manager/Archive or copied to a separate research Image Manager/Archive. De-identification may not be required for local research collections, but for those maintained centrally (outside the
4000 enterprise), remapping of identifiers to predefined pseudonyms is often required.

A specific Document Title of “For Research Collection Export” is provided for such use cases, which are otherwise no different from the foregoing teaching file and clinical trial use cases in terms of user actions, actors or sequencing of transactions.

17.4.4 Publication Authoring Use Cases

4005 The selection of instances for use in a publication shares many similarities with use cases for teaching files. De-identification of the DICOM Header and the pixel data is required. The disposition for these use cases should reference the target author of the selected instances. A specific Document Title of “For Publication Export” (TCE008) is provided for such use cases, which are otherwise no different from the foregoing teaching use cases in terms of user actions,
4010 actors or sequencing of transactions. This use case is supported by the process flow shown in Figure 17.4.1-1.

18 Cross-Enterprise Document Sharing for Imaging (XDS-I.b) Integration Profile

4015 **IMPORTANT NOTE:** *The Cross-Enterprise Document Sharing for Imaging (XDS-I) Integration Profile (originally found here) has been deprecated and is replaced by a functionally equivalent profile called Cross-Enterprise Document Sharing for Imaging (XDS-I.b), which is described in the remainder of this section.*

4020 The Cross-Enterprise Document Sharing (XDS.b) Profile in the IHE IT Infrastructure Domain provides a solution for sharing (publishing, finding and retrieving) documents across a group of affiliated enterprises. The XDS for Imaging (XDS-I.b) Profile, defined here, extends and specializes the mechanisms defined by XDS.b to support imaging “documents”, specifically including the following:

- 4025 • Imaging studies that include images acquired on a broad range of different modalities, as well as evidence documents (e.g., post-processing measurements/analysis outcome), and presentation states.
- Diagnostic reports resulting from the interpretation of one or more related imaging studies provided in a ready-for-display form
- A selection of diagnostically significant images associated with the report content.

4030 These document types along with the actor capabilities required to share them are defined by this profile.

4035 Since the XDS for Imaging (XDS-I.b) Profile depends on and extends the IT Infrastructure XDS.b Profile including the use of terms defined in XDS.b (e.g., XDS Affinity Domain, submission set, etc.) the reader of XDS-I.b is expected to have read and understood the XDS Profiles (See ITI TF-1: 10). The XDS-I.b specification does not repeat requirements and text for the XDS-defined Actors Document Repository, Document Registry, and Document Consumer, and does not place any new requirements on these actors.

4040 Both the XDS.b and XDS for Imaging (XDS-I.b) Integration Profiles are not intended to address all cross-enterprise EHR communication needs. Many scenarios may require the use of other IHE Integration Profiles, such as Patient Identifier Cross-Referencing (PIX), Audit Trail and Node Authentication (ATNA), Enterprise User Authentication (EUA), Cross-Enterprise User Authentication (XUA) and Retrieve Information for Display (RID). Other scenarios may be only partially supported, while still others may require future IHE Integration Profiles, which will be defined by IHE as soon as the necessary base standards are available. Specifically:

- 4045 1. The operation of any XDS Affinity Domain will require that a proper security model be put in place. It is expected that a range of security models should be possible. Although the XDS-I.b Integration Profile is not intended to include nor require any specific security model, it is required that XDS-I.b implementers shall group XDS-I.b actors with actors from the IHE Audit Trail and Node Authentication and will need an Access Control capability that operates in such a cross-enterprise environment. New IHE Integration
4050 Profiles have been identified as candidates (e.g., Public Key Infrastructure, Access

Control, etc.). There is a discussion of XDS-I.b security considerations in RAD TF-1: Appendix H.

- 4055
2. XDS and XDS-I.b do not address transactions for the management or configuration of an XDS Affinity Domain. For example, the configuration of network addresses or the definition of what type of clinical information is to be shared is specifically left up to the policies established by the XDS Affinity Domain.
 - 4060
 3. XDS and XDS-I.b do not specifically address the patient information reconciliation process necessary between the XDS Affinity Domain and any other local patient identity domains that Document Sources and Document Consumers may be members of. For a discussion of some of these issues see RAD TF-1: Appendix G.
 - 4065
 4. XDS and XDS-I.b do not directly address the rendering and display of the documents retrieved by the Document and Imaging Document Consumers. Users wishing to achieve a well-defined level of display/ rendering capability simply need to request systems that combine the XDS-I.b Imaging Document Consumer Actor with an Image Display Actor from the appropriate Profile (e.g., Mammography Image, NM Image, Basic Image Review, etc.).

18.1 Actors/ Transactions

4070

Figure 18.1-1 shows the actors directly involved in this profile and the transactions between actors. The shaded XDS actors are NOT actually included in this profile but are included to show the other endpoint of transactions that ARE part of the profile (e.g., the Document Repository Actor that is the endpoint for the Provide and Register Imaging Document Set – MTOM/XOP Transaction). As a result, the shaded actors are not listed in Table 18.1-1. The XDS-I.b Profile does not place any additional requirements on any of these actors above and beyond what it required of them by the ITI XDS.b Profile.

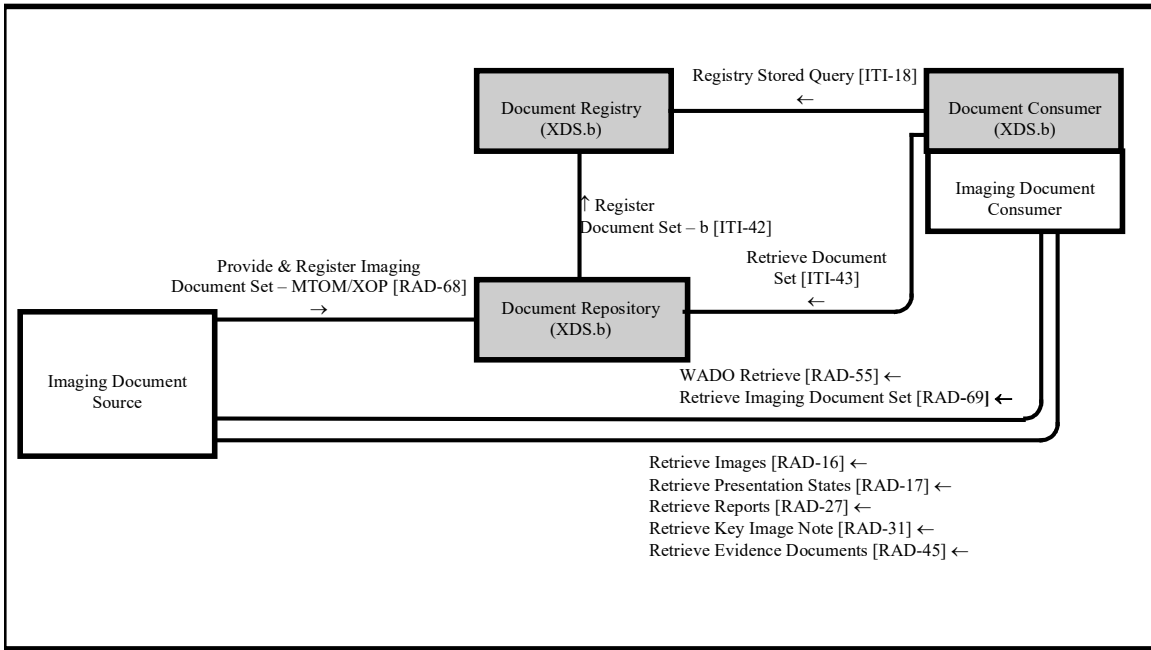

4075

Figure 18.1-1: Cross-Enterprise Document Sharing for Imaging Diagram

Table 18.1-1 lists the transactions for each actor directly involved in the Cross-Enterprise Document Sharing for Imaging (XDS-I.b) Profile. In order to claim support of this integration profile, an implementation shall perform the required transactions (labeled “R”). Transactions labeled “O” are optional. A complete list of options defined by this integration profile is listed in Section 18.2. Note the grouping of actors described in Section 2.5.

4080

Table 18.1-1: Cross-enterprise Document Sharing for Imaging Integration Profile - Actors and Transactions

Actors	Transactions	Optionality	TF Reference
Imaging Document Consumer	Retrieve Images [RAD-16]	O (Note 1)	RAD TF-2: 4.16
	Retrieve Presentation States [RAD-17]	O	RAD TF-2: 4.17
	Retrieve Reports [RAD-27]	O (Note 1)	RAD TF-2: 4.27
	Retrieve Key Image Note [RAD-31]	O	RAD TF-2: 4.31
	Retrieve Evidence Documents [RAD-45]	O (Note 1)	RAD TF-3: 4.45
	WADO Retrieve [RAD-55]	O (Note 1)	RAD TF-3: 4.55
	Retrieve Imaging Document Set [RAD-69]	O (Note 1)	RAD TF-3: 4.69
Imaging Document Source	Provide and Register Imaging Document Set – MTOM/XOP [RAD-68]	R (Note 2)	RAD TF-3: 4.68
	Retrieve Images [RAD-16]	R (Note 3)	RAD TF-2: 4.16
	Retrieve Presentation States [RAD-17]	R (Note 3)	RAD TF-2: 4.17
	Retrieve Reports [RAD-27]	R (Note 3)	RAD TF-2: 4.27
	Retrieve Key Image Note [RAD-31],	R (Note 3)	RAD TF-2: 4.31
	Retrieve Evidence Documents [RAD-45]	R (Note 3)	RAD TF-3: 4.45
	WADO Retrieve [RAD-55]	R (Note 3)	RAD TF-3: 4.55
	Retrieve Imaging Document Set [RAD-69]	R (Note 3)	RAD TF-3: 4.69

4085

- Note 1: At least one of the optional retrieve transactions is required to be supported. Refer to Section 18.4 for additional requirements on the Imaging Document Consumer.
- Note 2: Support of at least one of the four document types described by the options in Section 18.2 is required.
- Note 3: These transactions are only required if the Imaging Document Source supports the ‘Set of DICOM Instances’ Option as described in Table 18.2-1.

4090

18.2 Integration Profile Options

Options that may be selected for this integration profile are listed in Table 18.2-1 along with the Actors to which they apply. Dependencies between options when applicable are specified in notes.

Table 18.2-1: Cross-enterprise Document Sharing for Imaging - Actors and Options

Actor	Options	TF Reference
Imaging Document Source	Set of DICOM Instances (Note 1)	RAD TF-1: 18.2.1
	PDF Report (Note 1)	RAD TF-1: 18.2.2
	CDA ³ Wrapped Text Report (Note 1)	RAD TF-1: 18.2.3
	CDA Imaging Report with Structured Headings (Note 1)	RAD TF-1: 18.2.4
	Remove Imaging Document	RAD TF-1: 18.2.5
	Reference ID	RAD TF-1: 18.2.6

³ CDA is the registered trademark of Health Level Seven International.

Actor	Options	TF Reference
Imaging Document Consumer	<i>No options defined</i>	-

4095 Note 1: At least one of these four options is required.

18.2.1 Set of DICOM Instances Option

4100 This option requires the Imaging Document Source to create a DICOM manifest that references DICOM instances, and to provide and register this document to the Document Repository. The Imaging Document Source is required to ensure that the referenced images from within a published manifest are available to be retrieved. For details of the transaction affected by this option, refer to RAD TF-3: 4.68.4.1.2.1.

18.2.2 PDF Report Option

4105 This option requires the Imaging Document Source to provide and register an Imaging Report in a PDF format to the Document Repository. The published report may contain embedded images or pre-computed links that reference images in a non-DICOM format. The Imaging Document Source is required to ensure that image references are valid links. For details of the transaction affected by this option, refer to RAD TF-3: 4.68.4.1.2.2.

18.2.3 CDA Wrapped Text Report Option

4110 This option requires the Imaging Document Source to send to the Document Repository a CDA R2 document containing a Text Report. For details, refer to RAD TF-3: 4.68.4.1.2.2.

18.2.4 CDA Imaging Report with Structured Headings Option

4115 This option requires the Imaging Document Source to send to the Document Repository a CDA R2 document containing an Imaging Report with Structured Headings. For details, refer to RAD TF-3: 4.68.4.1.2.2.

18.2.5 Remove Imaging Document Option

4120 This option uses the ITI Remove Metadata and Documents (RMD) Profile to enable the Imaging Document Source to remove published imaging documents (e.g., imaging manifest and reports) from a Document Repository and related metadata from the Document Registry. Use of this option depends upon an Imaging Document Source participating in an environment with an RMD Document Registry and Document Repository.

An Imaging Document Source shall be grouped with an RMD Document Administrator that supports the Remote Registry Option and the Remote Repository Option.

4125 When the Imaging Document Source determines that a report is to be deleted, the grouped Document Administrator shall remove the metadata of the report from the Document Registry

using the Remove Metadata [ITI-62] transaction, and remove the report from the Document Repository using the Remove Documents [ITI-86] transaction.

4130 When the Imaging Document Source determines that all referenced objects in a manifest are to be deleted (i.e., imaging study has been deleted), the grouped Document Administrator shall remove the metadata of the manifest from the Document Registry using the Remove Metadata [ITI-62] transaction, and remove the manifest from the Document Repository using the Remove Documents [ITI-86] transaction.

4135 Note 1: This option is not used when the Imaging Document Source determines that a manifest is to be replaced (i.e., some but not all referenced objects in the manifest have been deleted, or referenced objects have been added). In this case, the Imaging Document Source submits a new manifest that references the remaining objects. This new manifest will replace the existing manifest in accordance with the RPLC (replace) Document Relationship as defined in RAD TF-3: 4.68.4.1.2.1.

4140 Note 2: For an Imaging Document Source that is grouped with an Image Manager that supports the Imaging Object Change Management Profile, when the Imaging Document Source deletes a study that has been published with a manifest, it may choose to either:

- Use the Remove Imaging Document Option to remove the study manifest metadata from the Document Registry and the Manifest from the Document Repository, or
- Create a corresponding Rejection Note for the deleted study and replace the published manifest with a new manifest which contains only the Rejection Note.

4145 The Imaging Document Source may choose either method depending on the integration need.

18.2.6 Reference ID Option

This option requires the Imaging Document Source to include Accession Number and Study Instance UID in the Document Sharing Metadata when submitting an imaging document (e.g., imaging manifest or report) to the Document Repository.

4150 An Imaging Document Source that supports this option shall include the Accession Number and its assigning authority in the referencedIdList attribute of the DocumentEntry metadata submitted to the XDS.b Document Registry for the imaging document as described in RAD TF-3: Table 4.68.4.1.2.3-1, if the Accession Number is known.

4155 An Imaging Document Source that supports this option shall include the Study Instance UID of the imaging study in the referencedIdList attribute of the DocumentEntry metadata submitted to the XDS.b Document Registry for the imaging document as described in RAD TF-3: Table 4.68.4.1.2.3-1, if the Study Instance UID is known.

4160 Use of this option depends upon an Imaging Document Source participating in an environment with an XDS.b Document Registry that supports the Reference ID Option. XDS.b Document Registries supporting the Reference ID Option (ITI TF-1: 10.2.6) store the values in the referencedIdList attribute. When the Reference ID Option is not supported by the Document Registry, then the values in referencedIdList are handled according to the rules outlined in ITI TF-3: 4.2.3.1.6 “Extra Metadata Elements”. Note that support for the Reference ID Option by the XDS.b Document Registry is necessary to enable the Document Consumer to perform a successful FindDocumentsByReferenceId Stored Query in the Registry Stored Query [ITI-18] transaction.

4165

18.3 Image Information Sharing Process Flow

4170 The sharing of imaging related information among different health professionals and facilities, even across administrative and geographic boundaries can lead to a large variety of information flows. Typical imaging information sets used in healthcare settings are well known, but the challenge is to distill the “exchange” scenarios to drive the sharing of imaging information across enterprises distributed over a community, region or nation.

18.3.1 Overview of Imaging Information Sharing Use Cases

4175 The following use case scenarios express the core imaging information sharing common to most clinical settings. They cover:

- 4180 1. **Routine imaging referral.** The referring physician in his office requests that a patient have an examination done at an imaging facility. The physician expects to have electronic access to the imaging report and to the images if needed after the examination has been performed on his patient. This use case is further analyzed in this profile.
- 4185 2. **Course of Treatment Consult.** An emergency physician orders an imaging examination for a patient at his hospital. After reviewing the preliminary report, the ER physician decides to consult a surgical specialist at the regional hospital for advice on a course of action. For this, the surgical specialist accesses the images and preliminary report and reviews them in order to propose, on the phone, a course of action for the patient. This use case is further analyzed in this profile.
- 4190 3. **Clinical Consult.** A general practitioner performs a routine imaging referral, reviews the shared imaging report and chooses to send the patient for evaluation by a specialist (e.g., an oncologist). The specialist needs access to the imaging report and full image set produced at the imaging facility where the patient had been sent by his general practitioner to perform the examination. This use case is further analyzed in this profile.
- 4195 4. **General imaging record access.** A patient relocates or decides to change her physician. The new physician needs to retrieve relevant information from the patient record, review its content, including recent labs and imaging studies. A similar situation occurs when a patient is admitted for an emergency and timely access to the patient’s past information is required, including prior imaging studies. This use case is further analyzed in this profile.

4200 This profile describes the information sharing transactions for care-delivering systems to publish patient’s imaging diagnostic documents (EHR-CR) for sharing across enterprises as longitudinal patient care records (HER-LR). The policies or administrative details regarding the sharing of imaging information are for the most part not explicitly discussed so as not to obscure clinical needs. Administrative variations between countries and regions are expected, and can be added or modified without losing the clinical information-sharing context.

Since the focus is on the sharing and access to patients imaging records rather than the entire workflow in which such information sharing takes place, other activities are described as though they are being done by telephone, paper mail, fax, etc. In an integrated electronic environment

4205 these other activities may be more automated, but those details are separate from the records access/sharing and are to be addressed by separate integration profiles.

18.3.2 Assumptions

4210 The imaging information needs to be shared between multiple care delivery organizations (information sources and consumers), each (typically) with its own RIS and PACS. The point of service (“POS”) for physicians may be supported by a variety of systems: hospital EMR, physician practice system, PACS viewers, EHR web application, etc.

The concept of sharing information across enterprises that have agreed to join in such a health information network is based on basic design principles that can be summarized in the following points:

- 4215 1. A group of healthcare enterprises have agreed to work together using a common set of policies and to share a common infrastructure of repositories and a registry for an affinity domain.
 - 4220 2. Information sources (e.g., EHR, lab system, PACS) select the “documents” they wish to share.
 - 4225 3. Documents may include any information in an agreed format (e.g., a PDF document, a DICOM manifest, etc.). Documents are stored in multiple document repositories.
 - 4230 4. Shared documents are registered with a central service called a document registry that tracks only indexing information and the location from which documents may be retrieved.
 - 4235 5. Information consumers may query this well-defined unique/singular indexing service (document registry) to find the document index information for any patient and the location from which documents may be retrieved (document repositories).
 - 4240 6. Information sources remain the owner of the documents shared in repositories and, thereby, remain responsible for replacing or deprecating its documents if necessary.
- 4230 In each one of the use cases, it is assumed that the people and the information systems that participate in a single “Affinity Domain” have agreed upon mechanisms to address:
- Governance: operational structure, data stewardship, etc.
 - Privacy: consent management and data masking controls
 - Security: Authorization and authentication, network security, audit trails, etc.
 - 4235 • Normalized patient ID schemes: MPI (Master Patient Index), unique information IDs, etc.
 - Coded Vocabularies used for registry information

18.3.3 Use cases

18.3.3.1 Routine Imaging Referral Use Case

4240 This scenario describes imaging information sharing in a typical patient referral and reporting use case where:

- An examination is performed upon the request of a referring physician:
- The referring physician accesses the regional health information network and reviews the report along with the key images and may optionally access the full image set that made the study.

4245 This scenario is characterized by all the information being provided for sharing at one time, as a single logical unit, when the imaging study is completed by the radiology enterprise (i.e., a single “document submission set”).

18.3.3.1.1 Process Flow

4250 Figure 18.3.3-1 highlights the people and systems participating in this regional health information network, including:

- *Physician Office*: A referring physician working out of a private office with a physician practice system for access to information
- *RIS/PACS Enterprise A*: A radiology enterprise with modality equipment and a RIS/PACS to manage report and imaging information: Radiology Enterprise A
- 4255 • *RIS/PACS Enterprise B*: Another radiology enterprise with a RIS/PACS to manage report and imaging information: Radiology Enterprise B
- *Document Registry*: A document registry that serves as the information index for the regional health information network

4260 In the process flow description, steps that pertain to information sharing are shown in bold (and numbered). In contrast, the steps that do not pertain to the focus of information sharing are shown in italic (and not numbered). These steps are expressed to ensure a more complete context.

Figure 18.3.3-2 shows the transaction diagram for this process flow.

4265 ***Exam is ordered***

The Referring Physician orders the examination and the patient goes to the Imaging Department: Radiology Enterprise A.

4270 This is well-understood workflow that may be executed using any combination of paper, faxes, telephone, and electronic communications. It may or may not be addressed using the IHE Scheduled Workflow Integration Profile.

Although this step is part of the use case, it is peripheral to the specific steps for sharing of imaging of information.

Step 1: Obtain Relevant Prior Imaging Information

- 4275 • The PACS at Radiology Enterprise A, where the acquisition and reporting is performed, does a query of the Document Registry to identify relevant prior images and reports. It should be noted that the determination of what is relevant is the responsibility of the consumer and not the registry.
- 4280 • The PACS at Radiology Enterprise A retrieves prior imaging information from a repository in another radiology enterprise within the regional health network: Radiology Enterprise B, in preparation for study acquisition and subsequent reporting

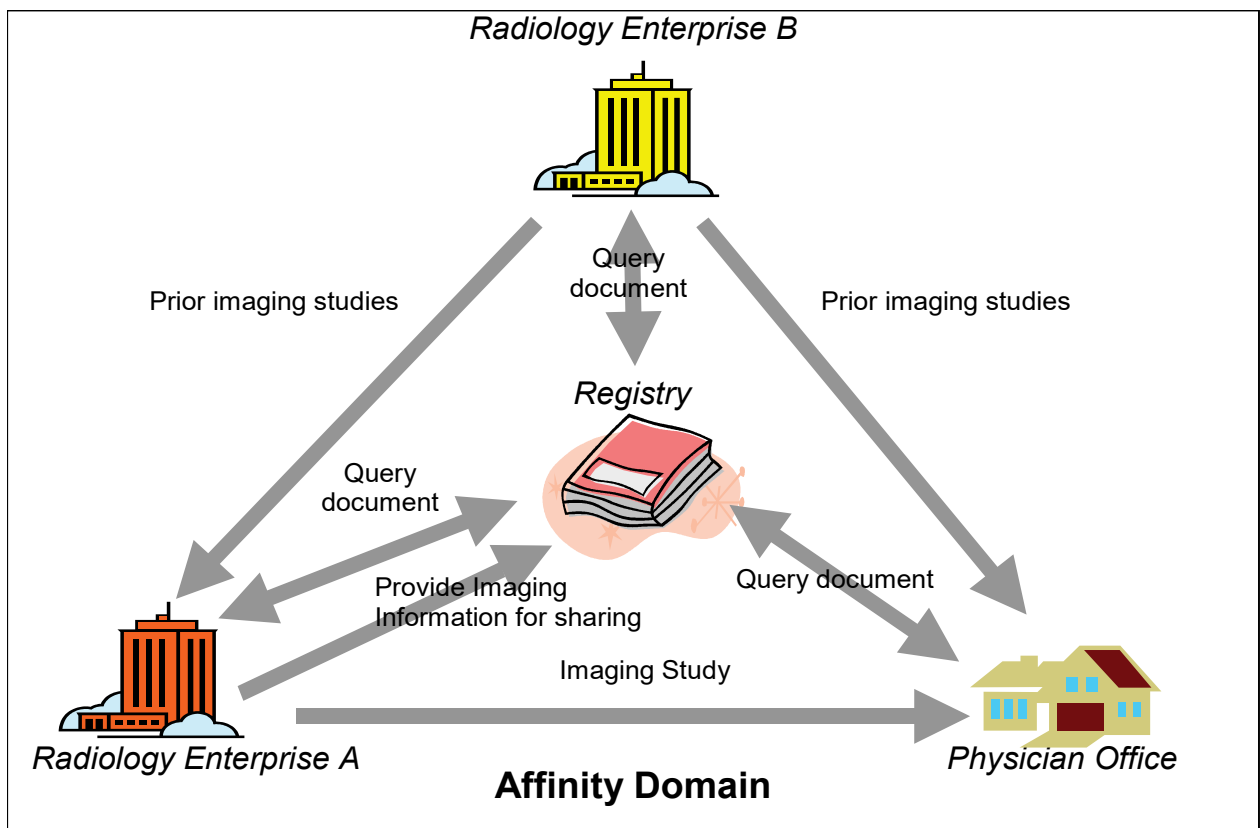

Figure 18.3.3-1: Data Flow within the Regional Health Network for a Routine Imaging Referral

4285 ***Exam is Acquired and Reported***

Images are sent from the modality to the PACS. This is well-understood workflow described in the SWF Profile.

The study is reported. This is well understood workflow that is managed by systems within Radiology Enterprise A

4290

Step 2: Share Imaging Information within the Regional Health Network (Affinity Domain)

- The PACS at Radiology Enterprise A, serving as a “Imaging Document Source”, provides imaging information to the document repository, which register the document in the registry, for sharing, including:

4295

- Acquired DICOM study
- Final report
- Key images along with annotations

Step 3: Obtain and Display Study Results

4300

- A physician practice system in the Physician’s office, serving as a document consumer, queries the Document Registry in the regional health network. This query may be triggered by the patient’s next appointment, a call from the patient to the physician’s secretary, an electronic notification that the examination’s result is available (using the IHE ITI Notification for Document Availability Profile), etc.

4305

- The physician practice system presents a list of imaging information available for the patient
- The referring physician selects the study results and relevant prior studies and reports
- The physician practice system in the Physician’s office, serving as an Imaging Document Consumer, retrieves the selected documents from the RIS/PACS Document Repositories in the regional health network and displays them to the referring physician.

4310

Referring Physician reviews the results

The Referring Physician reviews the results of the examination: the report and images from the RIS/PACS in Radiology Enterprise A, and the results of prior examinations: reports and images from the RIS/PACS in Radiology Enterprise B

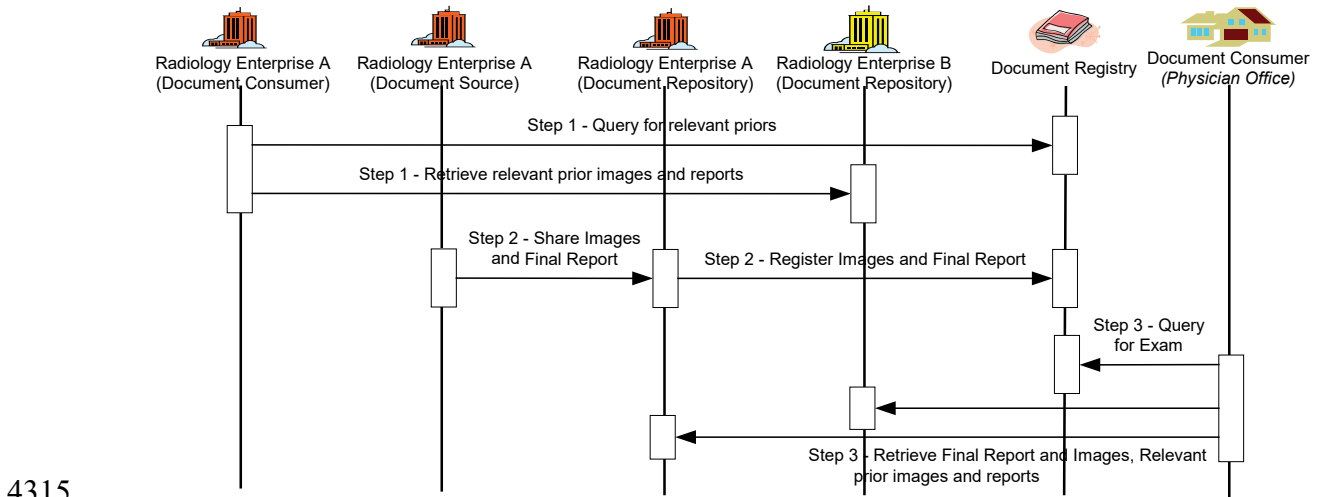

Figure 18.3.3-2: Process Flow – Routine Imaging Referral Use Case

18.3.3.2 Course of Treatment Consult Use Case

4320 This scenario is a variation on the routine imaging referral use case in that an addendum is generated after completion of the final report. As such, this scenario is characterized by information being provided for sharing at two separate times while ensuring that the initial information is supplemented by the addendum report.

The use of addendum reports is commonly encountered in a course of treatment consultation where:

- 4325 • An ER physician orders an exam, and the study is acquired in the affiliated radiology department.
- A department radiologist creates and shares a report as well as identifies key images and annotations.
- 4330 • A remotely located surgical specialist, at the request of the ER physician, reviews the report along with key images and the full study, and provides a consult to the ER physician (this use case does not constrain the method for communicating the results of the consult, e.g., phone, fax, etc.).
- The radiologist identifies additional information and completes an addendum to the initial report.

4335 Note that the scenario where the radiologist seeks an opinion from a more senior radiologist is similar to this use case.

18.3.3.2.1 Process Flow

The process flow description and steps are as for the routine imaging referral, but with the following variations (shown in bold):

Exam is ordered

4340 *Step 1: Obtain Relevant Prior Imaging Information*

Exam Acquisition and Reporting

Step 2: Share Imaging Information within the Regional Health Network (Affinity Domain)

- 4345 • The PACS at Enterprise A, serving as a “Imaging Document Source”, provides imaging information to the document repository, which register the document in the registry, for sharing, including:
 - Acquired DICOM study
 - Report
 - Key images along with annotations

Step 3: Obtain and Display Study Results

4350 *ER Physician reviews the results*

Step 4: Share Addendum to Report within the Regional Health Network (Affinity Domain)

- Sometime later on, the radiologist creates an addendum to the initial report. This addendum is transcribed into the RIS at Enterprise A and signed off by the radiologist. This addendum must now supplement the initial report.
- 4355 • The RIS at Enterprise A performs a document query of the document registry for the first submission set.
- The RIS at Enterprise A, serving as a “Imaging Document Source”, provides the addendum for sharing to the document registry including the content of the first submission set and declaring the new document as an addendum to the initial report.

4360 Figure 18.3.3-3 shows the transaction diagram for this process flow.

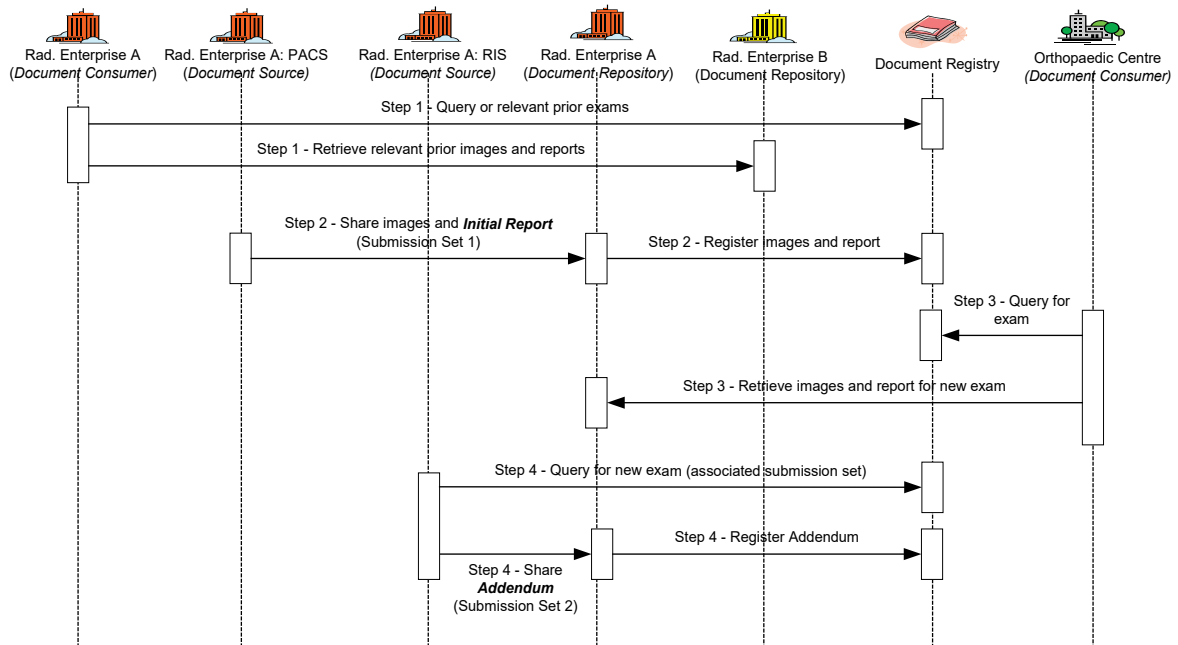

Figure 18.3.3-3: Process Flow – Course of Treatment Consult Use Case

18.3.3.3 Clinical Consult Use Case

4365 This scenario is an extension of the routine imaging referral use case in that a consult report is generated based from the original imaging exam and radiologist report. As such, this scenario is characterized by information being provided for sharing at two separate times by two separate source systems.

4370 The reports shared in this use case are based on the same initial imaging exam. However, the reports are generated by different people and registered by different systems.

The generation of consult reports is commonly encountered in cancer treatment. As such, the following clinical consult use case is used to describe the scenario:

- A general practitioner performs a routine imaging referral (as per Use Case 1).
- In reviewing the imaging exam report from the radiologist, the practitioner chooses to send the patient to an oncologist for a consultation.
- 4375 • The oncologist, located at a Cancer Center, reviews the report along with key images, the full study, and past imaging information records for the patient
- The oncologist generates an additional report that is made available to the general practitioner
- 4380 • The general practitioner reviews the oncologists report and takes appropriate treatment action

18.3.3.3.1 Process Flow

Figure 18.3.3-4 highlights the people and systems participating in this regional health information network. These are the same as for the routine imaging referral but with one additional participant:

4385

- *Physician Office*
- *RIS/PACS Enterprise A*
- *RIS/PACS Enterprise B*
- *Document Registry*

4390

- *Oncologist: An oncologist working out of a cancer center: Cancer Center. This center has an Electronic Health Record (EHR) application that serves as the POS application for reviewing imaging information within the regional health network. The EHR application has DICOM Viewing capabilities*

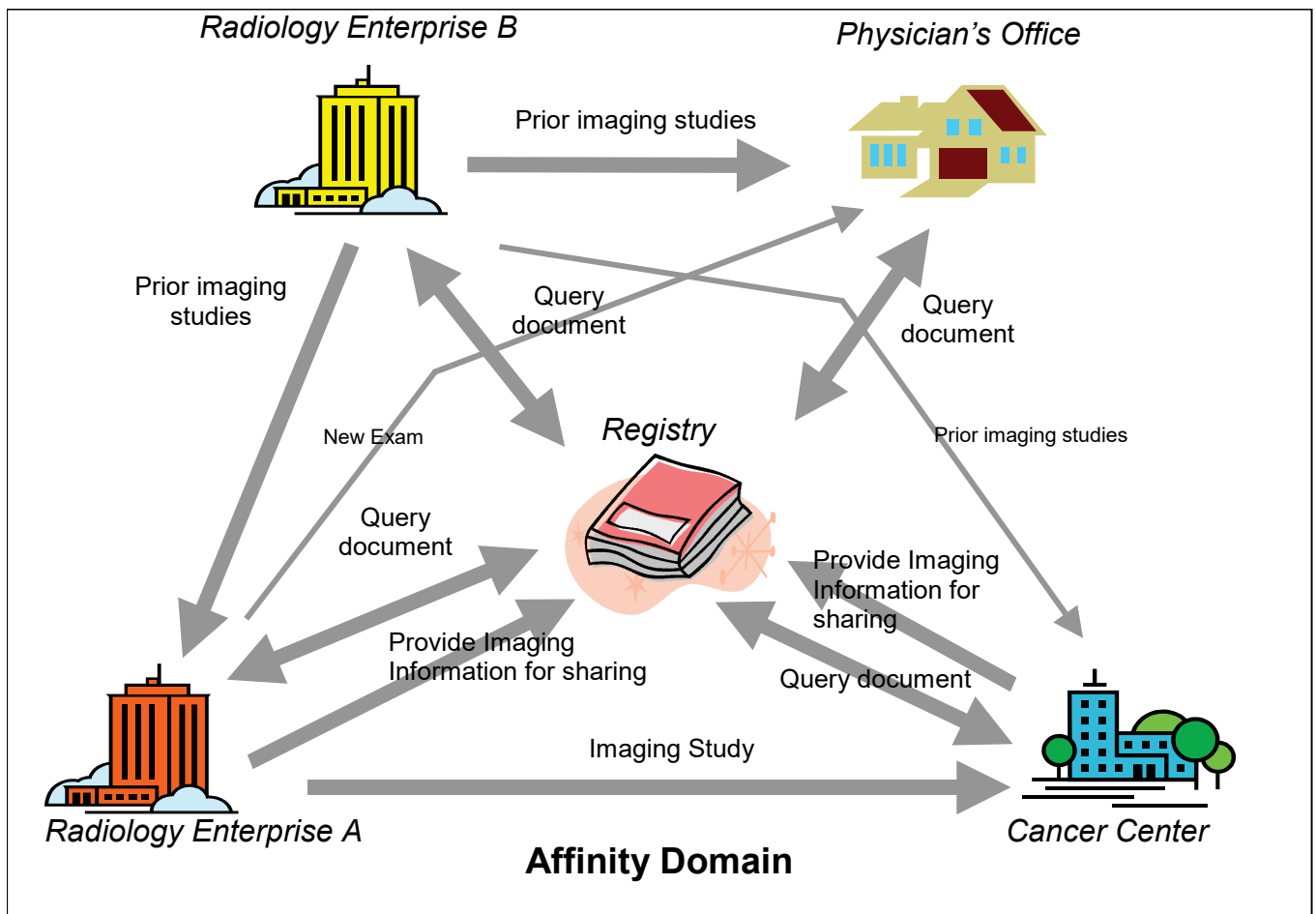

4395

Figure 18.3.3-4: Data Flow within the Regional Health Network for a Clinical Consult

The process flow description and steps are as for the routine imaging referral, but with certain variations. The variations that pertain to information sharing are shown in bold (and numbered). In contrast, the variations that do not pertain to the focus of information sharing are shown in italic (and not numbered).

4400

Exam is ordered

Step 1: Obtain Relevant Prior Imaging Information

Exam Acquisition and Reporting

Step 2: Share Imaging Information within the Regional Health Network (Affinity Domain)

4405

Step 3: Obtain and Display Study Results (General Practitioner)

- This is identical to Step 3 in the routine imaging referral use case
- Based on the radiology report, the general practitioner determines that a consult with an oncologist is required

Step 4: Obtain and Display Study Results (Oncologist)

- 4410 • The EHR application in the oncologist’s office, serving as a document consumer, queries the document registry in the regional health network. This query is triggered by a consult request from the general practitioner via paper, fax, phone, and/or electronic notification. The EHR application presents a list of imaging information available for the patient, including the most recent exam completed at Radiology Enterprise A
- 4415 • The oncologist selects the exam reported by the radiologist as well as a number of relevant prior exams
- The EHR application in the oncologist’s office, serving as an Imaging Document Consumer, retrieves the documents selected from the RIS/PACS document repositories in the regional health network and displays them to the oncologist
- 4420 • The oncologist reviews the images using image manipulation tools such as window level, zoom, pan, invert, measurement, etc. The oncologist may also apply 3D rendering such as multi-planar reformatting

Oncologist Generates Consult Report

- The oncologist reviews the results of the examination along with prior exams
- 4425 • The oncologist generates a consult report

Step 5: Share Consult Report within the Regional Health Network (Affinity Domain)

- The EHR application in the oncologist’s office, serving as an “Imaging Document Source”, provides the consult report to the document registry for sharing. This has reference to the original imaging exam, which was used during the consult.

4430 Figure 18.3.3-5 shows the transaction diagram for this process flow.

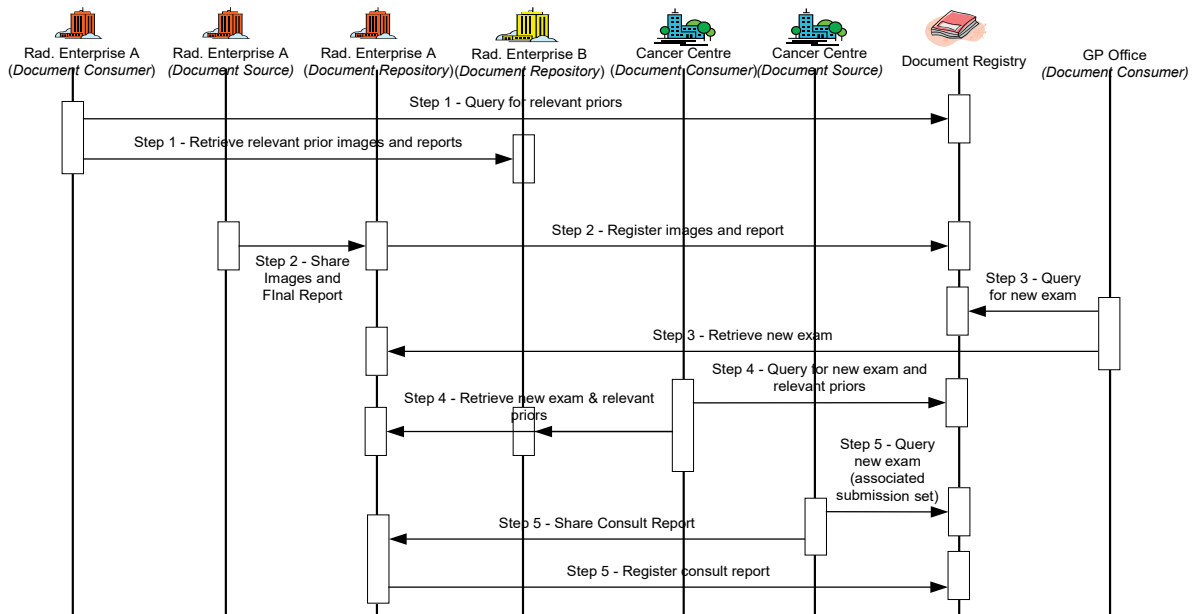

Figure 18.3.3-5: Process Flow – Clinical Consult Use Case

18.3.4 Queries

4435 As presented in the use cases, human or machine users may query the Registry in order to retrieve documents in a subsequent step, based on the query result. The type of query attributes may vary between users or query scenarios, depending on the intent of the query. For instance, human users often wish to query specifically, restricting the search by several query attributes and values.

The following query attributes are relevant (but not exhaustive):

- 4440
 - Patient Identity – The patient is expected to be identified by Patient ID
 - Exam Identity – The physician is looking for a specific exam. The attributes used to identify the exam may include one or more of the following:
 - Date
 - Modality
- 4445
 - Body part/anatomical region
 - Document type – images, diagnosis, progress report, preliminary report, etc.
 - Author – in the case of reports, the physician may well identify the report by its author i.e., the radiologist and / or specialist

4450 The metadata in the query response needs to be sufficient to allow the system consumer to parse the response and identify relevant priors. Relevant metadata includes (but is not limited to):

- Exam date
- Modality
- Body part/anatomical region
- Procedure code

4455 18.4 Consumer Processing

18.4.1 Consumer Processing – Set of DICOM Instances

4460 When the Imaging Document Consumer retrieves a manifest from the Document Repository, it is expected to decode the Key Object Selection Document Instance in order to find the references to DICOM objects. The Imaging Document Consumer is also expected to retrieve the referenced DICOM objects using DICOM retrieve or WADO. It should not make any assumptions about whether one or more studies are referenced within the Key Object Selection Document.

18.5 Patient Information Reconciliation

These considerations can be found in Appendix G.

18.6 Security Considerations

4465 All XDS-I.b actors shall be grouped with either a Secure Node or Secure Application Actor from the ITI ATNA Profile. These actors shall also support the Radiology Audit Trail Option.

This grouping is required to provide the capability for security auditing, for establishing a trust relationship between systems exchanging information, and to enable secure data exchange. Some care sites may use alternate mechanisms for providing equivalent security.

4470 Other security considerations can be found in Appendix H.

19 Mammography Image Integration Profile

4475 The Mammography Image Profile specifies how DICOM Mammography images and evidence objects are created, exchanged and used. It describes how Acquisition Modalities transfer Full Field Digital Mammography (FFDM) Images, how CAD systems act as Evidence Creators, and how Image Displays should retrieve and make use of images and CAD results. It defines the basic display capabilities Image Displays are expected to provide, and which attributes should be used to implement those capabilities.

4480 Managing the process of creating, storing and using Mammography Image content is similar to workflow for other image content (e.g., see Scheduled Workflow and Post-Processing Workflow Profiles).

4485 The Mammography Image Profile is designed to provide faithful and complete storage and retrieval of Mammography data and sufficient display functionality to allow adequate review of current and prior images and CAD results for the purpose of primary interpretation by radiologists. It should also be sufficient for secondary review for referring physicians. It does not address the use of other modalities appropriate for breast imaging such as MR or US.

19.1 Actors/ Transactions

Figure 19.1-1 shows the actors directly involved in the Mammography Image Integration Profile and the relevant transactions between them.

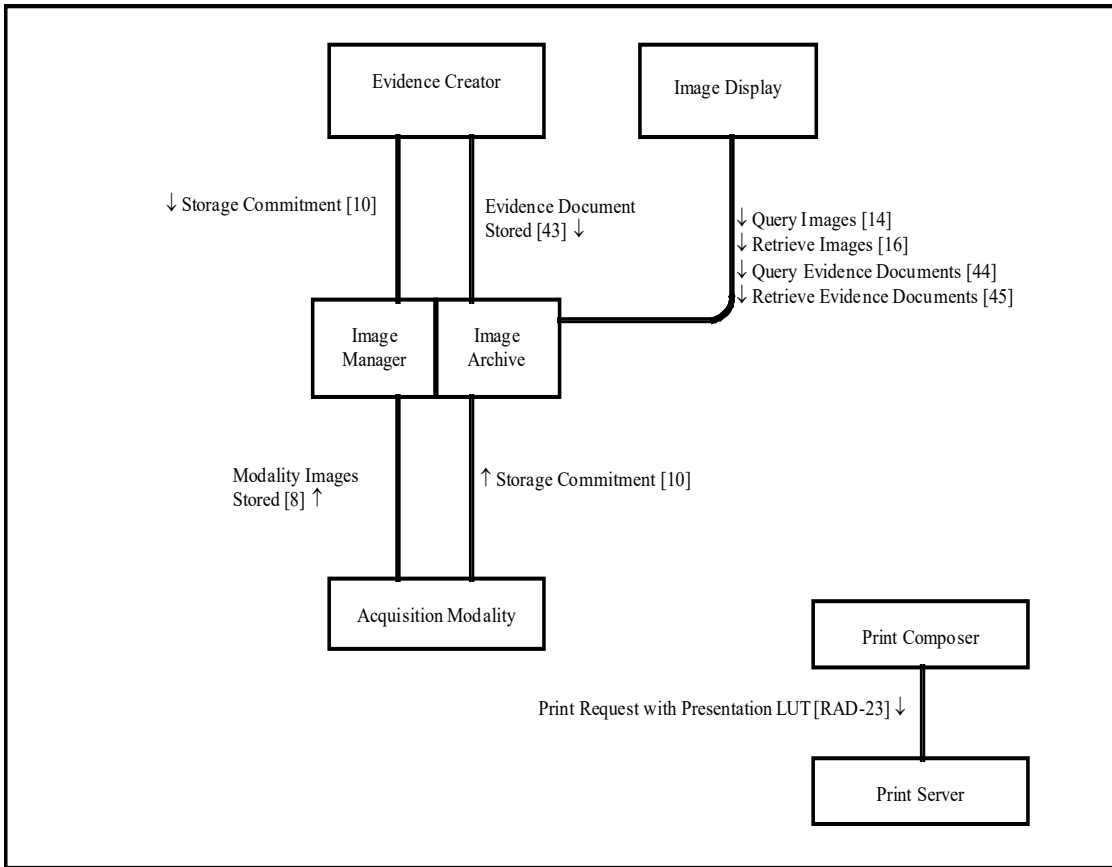

4490

Figure 19.1-1: Mammography Image Profile Actor Diagram

Table 19.1-1 lists the transactions for each actor directly involved in the Mammography Image Profile. In order to claim support of this integration profile, an implementation must perform the required transactions (labeled “R”). Transactions labeled “O” are optional. A complete list of options defined by this integration profile and that implementations may choose to support is listed in Section 19.2.

4495

Table 19.1-1: Mammography Image Integration Profile - Actors and Transactions

Actors	Transactions	Optionality	TF Reference
Acquisition Modality	Modality Images Stored [RAD-8]	R	RAD TF-2: 4.8
	Storage Commitment [RAD-10]	R	RAD TF-2: 4.10
Evidence Creator	Evidence Document Stored [RAD-43]	R	RAD TF-3: 4.43
	Storage Commitment [RAD-10]	R	RAD TF-2: 4.10
Image Manager/Archive	Modality Images Stored [RAD-8]	R	RAD TF-2: 4.8
	Evidence Document Stored [RAD-43]	R	RAD TF-3: 4.43
	Storage Commitment [RAD-10]	R	RAD TF-2: 4.10
	Query Images [RAD-14]	R	RAD TF-2: 4.14
	Retrieve Images [RAD-16]	R	RAD TF-2: 4.16

Actors	Transactions	Optionality	TF Reference
	Query Evidence Documents [RAD-44]	R	RAD TF-3: 4.44
	Retrieve Evidence Documents [RAD-45]	R	RAD TF-3: 4.45
Image Display	Query Images [RAD-14]	R	RAD TF-2: 4.14
	Retrieve Images [RAD-16]	R	RAD TF-2: 4.16
	Query Evidence Documents [RAD-44]	R	RAD TF-3: 4.44
	Retrieve Evidence Documents [RAD-45]	R	RAD TF-3: 4.45
Print Composer	Print Request with Presentation LUT [RAD-23]	R	RAD TF-2: 4.23
Print Server	Print Request with Presentation LUT [RAD-23]	R	RAD TF-2: 4.23

19.2 Mammography Image Integration Profile Options

4500 Options that may be selected for this integration profile are listed in the Table 19.2-1 along with the Actors to which they apply. Dependencies between options when applicable are specified in notes.

Table 19.2-1: Evidence Documents - Actors and Options

Actor	Options	TF Reference
Acquisition Modality	Partial View	RAD TF-2: 4.8.4.1.2.3.1
Image Archive/Manager	<i>No options defined</i>	--
Image Display	Partial View	RAD TF-2: 4.16.4.2.2.1.1.7

4505 **19.3 Mammography Image Profile Process Flow**

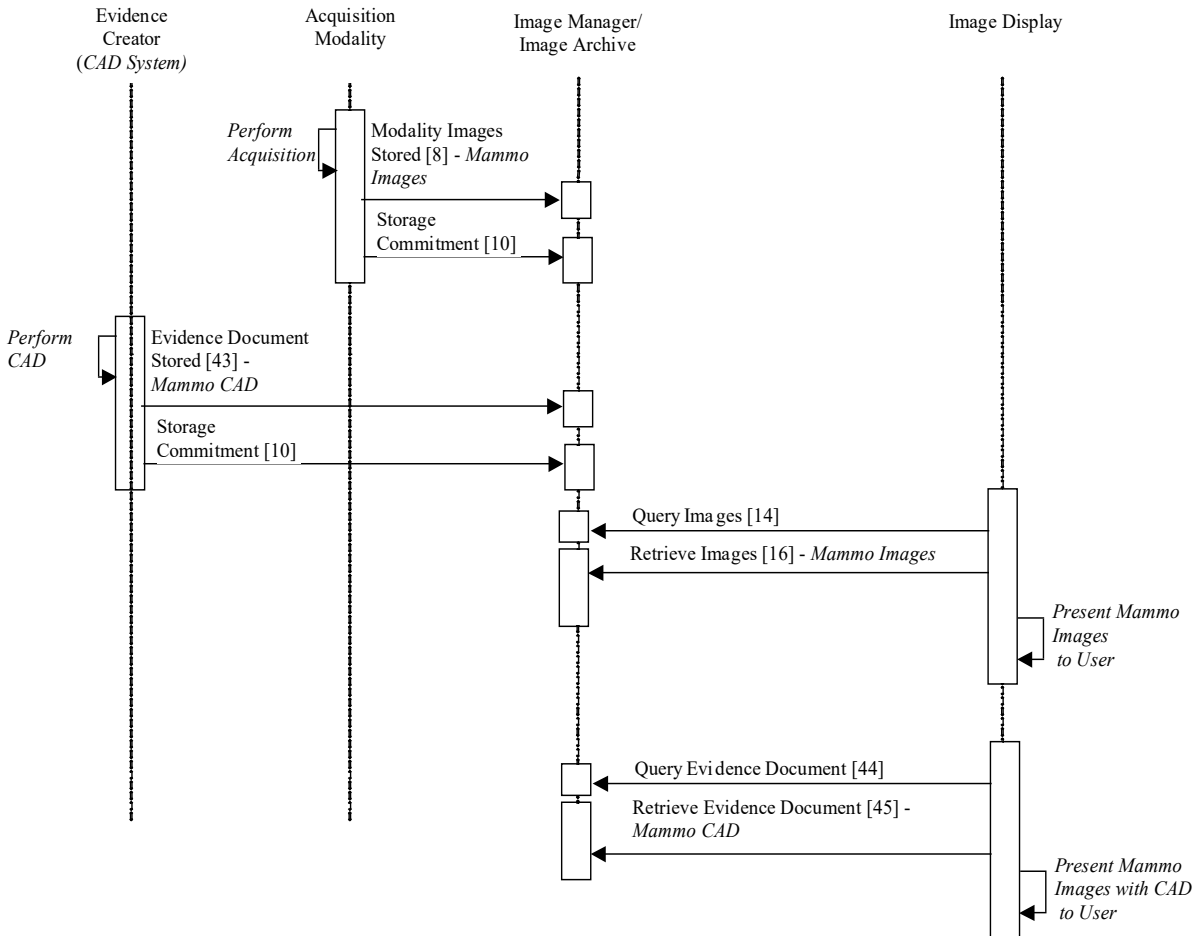

Figure 19.3-1: Basic Process Flow in Mammography Image Profile

The workflow between the Acquisition Modality and the Evidence Creator that is the CAD device is currently outside the scope of IHE to define.

4510

20 Image Fusion (FUS)

This section intentionally, temporarily left blank.

21 Import Reconciliation Workflow (IRWF)

4515 **IMPORTANT NOTE:** *As of June 2012, IHE introduces an updated Import Reconciliation Profile (IRWF.b) for Trial Implementation. In addition to the original use cases, several new use cases are addressed, and the underlying mechanisms are improved. The IRWF Profile documented in this section has been deprecated by the Radiology Domain and is now replaced by the IRWF.b. . When that supplement becomes Final Text, the contents of this section will*
4520 *be removed. In the interim, new implementations should be based on IRWF.b, found at http://www.ihe.net/Technical_Frameworks/#radiology.*

The Import Reconciliation Workflow Integration Profile (IRWF) specifies both the data and workflow requirements for importing existing Evidence Objects and importing Hardcopy from an external Enterprise. Worklists and Patient Demographics Query are provided as mechanisms
4525 to provide local patient and procedure information to be used in the process of reconciling the imported patient/procedure information. Procedure Step Completed messages enable subsequent workflow steps to occur based on the importation of the Evidence Objects.

Reconciling critical patient demographics (e.g., Patient Name, Patient ID) and order/procedure Information (e.g., Accession Number) is an important part of the importation process since the
4530 local Enterprise will typically have different identifiers (for patient, orders, etc.) from the Enterprise that created the Evidence Objects or Hardcopy being imported.

When the attribute values must be changed, this Profile provides a mechanism to preserve a copy of the original values inside the imported DICOM Composite Objects.

This profile also makes it possible to determine whether images, reports and other evidence
4535 objects associated with a particular import have been stored (archived) and are available to subsequent workflow steps, such as post-processing and reporting.

21.1 Actors/Transactions

Figure 21.1-1 diagrams the actors involved with this profile and the transactions between them.

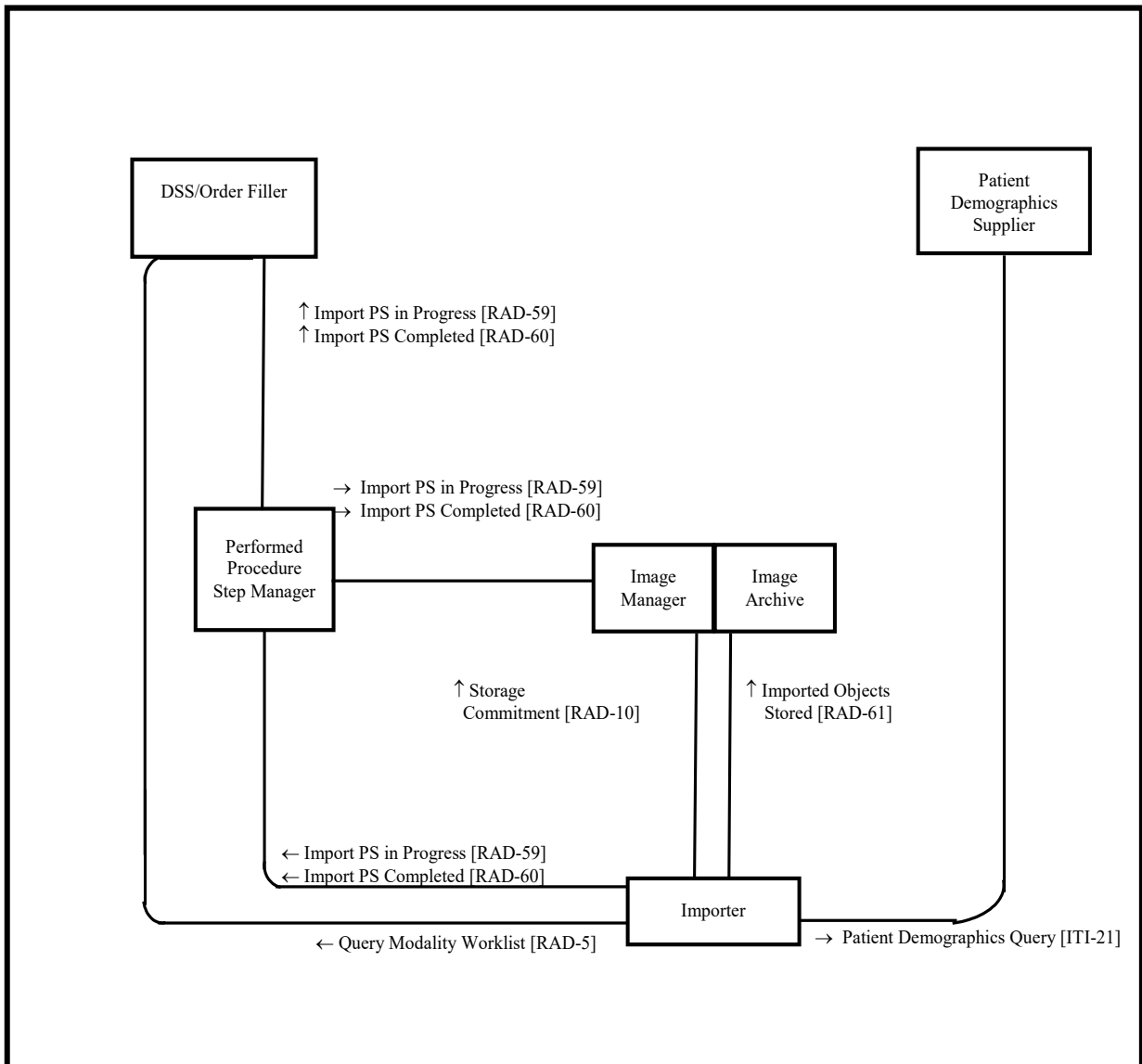

4540

Figure 21.1-1: Import Reconciliation Workflow Diagram

4545

Table 21.1-1 lists the transactions for each actor directly involved in the Import Reconciliation Workflow Integration Profile. In order to claim support of this integration profile, Import Reconciliation Actors present in the Scheduled Workflow Profile must also support Scheduled Workflow and perform the required transactions (labeled “R”). Transactions labeled “O” are optional. A complete list of options defined by this integration profile that implementations may choose to support is listed in Section 21.2.

Table 21.1-1: Import Reconciliation Workflow Integration Profile - Actors and Transactions

Actors	Transactions	Optionality	TF Reference
Department System Scheduler/ Order Filler	Query Modality Worklist [RAD-5]	R	RAD TF-2: 4.5
	Import Procedure Step In Progress [RAD-59]	R	RAD TF-3: 4.59
	Import Procedure Step Completed [RAD-60]	R	RAD TF-3: 4.60
Patient Demographics Supplier	Patient Demographics Query [ITI-21]	R	ITI TF-2a: 3.21
Importer	Query Modality Worklist [RAD-5] (Note 1)	O	RAD TF-2:4.5
	Patient Demographics Query [ITI-21] (Note 1)	O	ITI TF-2a: 3.21
	Import Procedure Step In Progress [RAD-59]	R	RAD TF-3: 4.59
	Import Procedure Step Completed [RAD-60]	R	RAD TF-3: 4.60
	Imported Objects Stored [RAD-61]	R	RAD TF-3: 4.61
	Storage Commitment [RAD-10]	R	RAD TF-2: 4.10
Image Manager/ Image Archive	Import Procedure Step In Progress [RAD-59]	R	RAD TF-3: 4.59
	Import Procedure Step Completed [RAD-60]	R	RAD TF-3: 4.60
	Imported Objects Stored [RAD-61]	R	RAD TF-3: 4.61
	Storage Commitment [RAD-10]	R	RAD TF-2: 4.10
Performed Procedure Step Manager	Import Procedure Step In Progress [RAD-59]	R	RAD TF-3: 4.59
	Import Procedure Step Completed [RAD-60]	R	RAD TF-3: 4.60

4550

Note 1: The Importer shall support at least one of the Query Modality Worklist or Patient Demographics Query transactions.

Refer to Table 2-1 for other profiles that may be pre-requisites for this profile

21.2 Import Reconciliation Workflow Integration Profile Options

4555

Options that may be selected for this integration profile are listed in the Table 21.2-1 along with the Actors to which they apply. Dependencies between options, when applicable, are specified in notes.

Table 21.2-1: Import Reconciliation Workflow - Actors and Options

Actor	Option	TF Reference
Department System Scheduler/ Order Filler	<i>No options defined</i>	-
Importer	Scheduled Import (Note 1)	RAD TF-1: 21.2.1
	Unscheduled Import (Note 1)	RAD TF-1: 21.2.2
	Billing and Material Management	RAD TF-3: 4.60
Image Manager/ Image Archive	<i>No options defined</i>	-
Performed Procedure Step Manager	<i>No options defined</i>	-

Note 1: The Importer shall support at least one of the Scheduled Import or Unscheduled Import Options.

4560 The Importer and Image Manager/ Image Archive will likely support a variety of DICOM SOP Classes. It is expected that this level of optionality will be documented in the DICOM Conformance Statement.

21.2.1 Scheduled Import Option

4565 Importers claiming the Scheduled Import Option are required to support the Query Modality Worklist transaction (see RAD TF-2: 4.5) to obtain import worklists and use the patient and procedure information provided to reconcile the imported data.

For further details of this option, refer to RAD TF-3: 4.59.4.1.2.3.1.

21.2.2 Unscheduled Import Option

4570 Importers claiming the Unscheduled Import Option are required to support the Patient Demographics Query transaction (See ITI TF-2a: 3.21) to obtain patient demographics for reconciling the imported data.

For further details of this option, refer to RAD TF-3: 4.59.4.1.2.3.2.

Note that the identifiers provided by the ITI Patient Demographic Supplier Actor are expected to be consistent with those that would be obtained using SWF transactions. This is necessary to ensure the synchronization of the Patient Demographics from both sources.

4575 21.3 Integration Workflow Process Flow

4580 This section describes the workflow related to importing DICOM data or importing hardcopy created external to the Enterprise. Import Reconciliation Workflow uses many transactions from Scheduled Workflow (See Section 3.3). In most cases there are no changes in these transactions. See Appendix C for an overview of the information exchange between the Department System Scheduler/Order Filler and Image Manager.

Once the desired information has been imported into the local Enterprise it is up to the local institution to determine the retention policies for physical media associated with the import (e.g., films, CDs, DVDs) and the imported data itself.

21.3.1 Import Process Flow

4585 This section describes the typical process flow for managed importation. This profile only applies to data from patients that have been registered and assumes that the patient demographics information is known and available to the local system and user. If the Patient is not registered, the data is imported and needs to be reconciled by other mechanisms such as PIR.

21.3.1.1 Use Cases

4590 The primary use cases for importing radiology information are:

1. External Acquisition or Read: An institution has referred the patient to an external facility for acquisition, or for reading. The institution receives the acquired study on media from the external facility and imports it to the local archive.

- 4595 2. External Priors: The institution receives media containing prior images and/or reports for a current patient. The data is imported to the local archive and associated with the patient's record so they can be referred to as priors during the reading of the current study.
- 4600 3. Patient Referral: The institution receives media containing a patient's radiological history associated with a referral or patient transfer. The data is imported to the local archive and associated with the patient's record.

The importation may be managed in two different ways:

- 4605 1. Scheduled Import: The institution schedules the import task on an importation worklist which provides the local demographics and local procedure information.
- 4605 2. Unscheduled Import: The institution does not electronically schedule the import task and instead relies on the Importer to obtain local demographics from a Demographics Supplier.

In either case it is a prerequisite that the patient has been registered so that locally correct demographic information for the patients is available. Importation of "locally unknown" patients followed by Patient Information Reconciliation is not covered by this integration profile.

- 4610 Importation could be performed piecewise on a physician's workstation, or batched at a central location.

The data may arrive at the institution by a variety of transport mechanisms including hardcopy (films, prints), media (CDs, DVDs) or simple network transfer. This profile does not dictate a particular transport mechanism.

- 4615 For any import, there may exist information in addition to the media, which will be taken into account by the importing enterprise but its usage is not specified by IHE. This information may be available electronically, written or orally. Main examples for such information are:

- Administrative information like checklists, importation rules, workflow codes or billing items.
 - Clinical information like lab reports, discharge summaries, ECGs, potentially as PDI web data.
- 4620

- 4625 Note that the person importing the Evidence Objects or Hardcopy can be assumed to have the most comprehensive and complete information available for the importing task. In case of exceptions, the import may need to be aborted (see RAD TF-3: 4.60.4.1.2.2 for Exception Management).

After the importation is done and the imported evidence objects are available through the Image Manager/ Image Archive (which may be indicated by an Instance Availability Notification), the enterprise may schedule subsequent steps like reading or reporting.

21.3.1.2 Scheduled Import Process Flow

4630 An enterprise internally schedules an import, e.g., associated with an external acquisition or read. There may be other scheduling items, which are not within the scope of the Technical Framework, but will be taken into account by the Enterprise:

- For external referrals, patient and order information needs to be conveyed to the external Enterprise.
- 4635 • Clinical information may be received in addition to the DICOM information, e.g., electronic referrals, Lab Reports, Clinical Summaries, or PDI web information.
- The importation of data is typically a scheduled event separate from how the data is used (images to be reported, historical data to be used in-conjunction with a current procedure, etc.).
- 4640 • The importation scheduling information may include instructions, e.g., which studies, series or images are to be imported.

The following steps can be identified in the scheduled process flow:

- Using Scheduled Workflow, the relevant study data to be imported is available in the scheduled procedure step. Note that the Patient Registration and Procedure Ordering all use the Scheduled Workflow Profile (See Sections 3.3.1, 3.3.2, 3.3.3).
- 4645 • Depending on the type of media to be imported, the procedure step can be scheduled to the appropriate Importing device (e.g., Film Scanner, PDI Workstation).
- The SCHEDULED IMPORT Option is used to import the evidence objects and reconcile the patient and procedure data (e.g., to change the recorded Patient ID to the local Patient ID) using the Modality Worklist Query. The resultant DICOM objects are stored in the PACS.
- 4650 • Errors and exceptions during import are handled by using Exception Management described in RAD TF-3: 4.60.4.1.2.2.
- Subsequent steps may be
- 4655 • performed, such as implicit post-processing (see Section 3.3.5);
- scheduled for a Post-Processing or Reporting Workflow, probably involving the Availability Notification Option.

4660 This process flow requires that the Patient be registered and that procedure step(s) be scheduled for the importation. Associated Patient Registration Scheduling, and subsequent Availability or Notification transactions are part of the Scheduled Workflow (See Section 3.3). The following sequence of steps describes the typical process flow for the scheduled import of patient data.

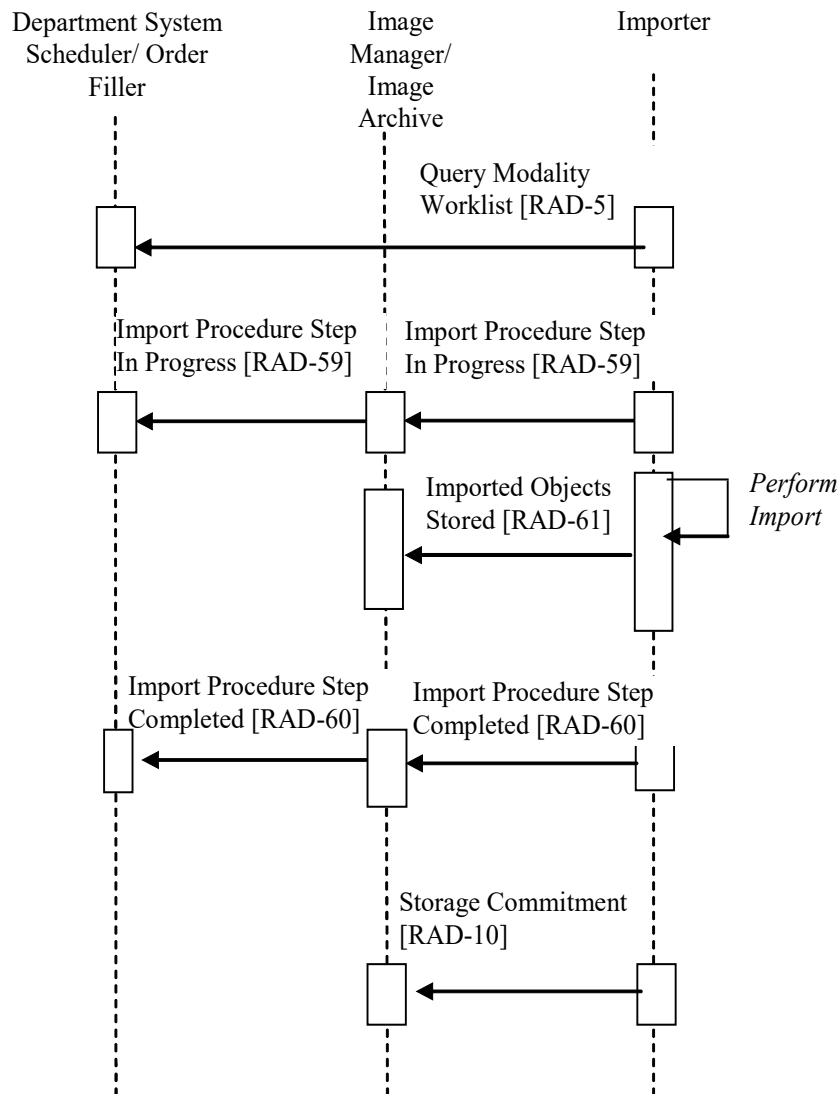

Figure 21.3.1-1: Scheduled Import Reconciliation Workflow Process Flow

4665 **21.3.1.2.1 Scheduled Import Data Reconciliation**

Importation requires that some of the Patient/Procedure information be treated differently than prescribed in Scheduled Workflow.

4670 The Study UID provided by the Modality Worklist shall be ignored and the reconciliation rules shall be followed. As part of the import process, the Importer reconciles the patient data as needed (e.g., to change the recorded Patient ID to the local Patient ID). See RAD TF-2: Appendix A.5 for a full list of the reconciliation requirements. The original DICOM object identifiers must be maintained in the imported DICOM Composite Objects. The policies of the importing enterprise will determine

- if demographics from the Import Data can be used (e.g., Birth Date, Patient Sex)

- 4675
- whether or how enterprise-specific codes in the imported data are coerced or ignored

21.3.1.3 Unscheduled Import Process Flow

4680 An enterprise has received evidence objects for import that are not part of an order or scheduled procedure in one of its information systems, e.g., relevant priors prior to a consultation. There is no scheduled procedure to trigger the importation. The actual task of importation may be a batched process that does not schedule individual importations.

- Aside from the physical media (e.g., films, CDs), there may be clinical information in addition to the DICOM data in electronic, written or oral format, such as referral letters. The incorporation of this information into the Enterprise is out of scope for the Import Reconciliation Workflow.

4685 The following steps can be identified in this process flow:

- The User does the import at an appropriate device (e.g., a film scanner is used to digitize films, a workstation with PDI capabilities is used to import PDI media).
 - The UNSCHEDULED IMPORT Option is used to retrieve the Patient Demographics information, import the Evidence Objects and to reconcile the patient data (e.g., to change the recorded Patient ID to the local Patient ID) using the Patient Demographics Query. The resultant DICOM objects are stored in the PACS.
 - Errors and exceptions during import are handled by using Exception Management described in RAD TF-3: 4.60.1.2.2.
 - The Evidence Objects are available from the PACS and may be used in subsequent scheduled or unscheduled steps, or at a later time.
- 4690
- 4695

This process flow requires that the Patient be registered. Associated Patient Registration, and subsequent Availability or Notification transactions are part of the Scheduled Workflow (See Section 3.3). The following sequence of steps describes the typical process flow for the unscheduled import of patient data.

4700

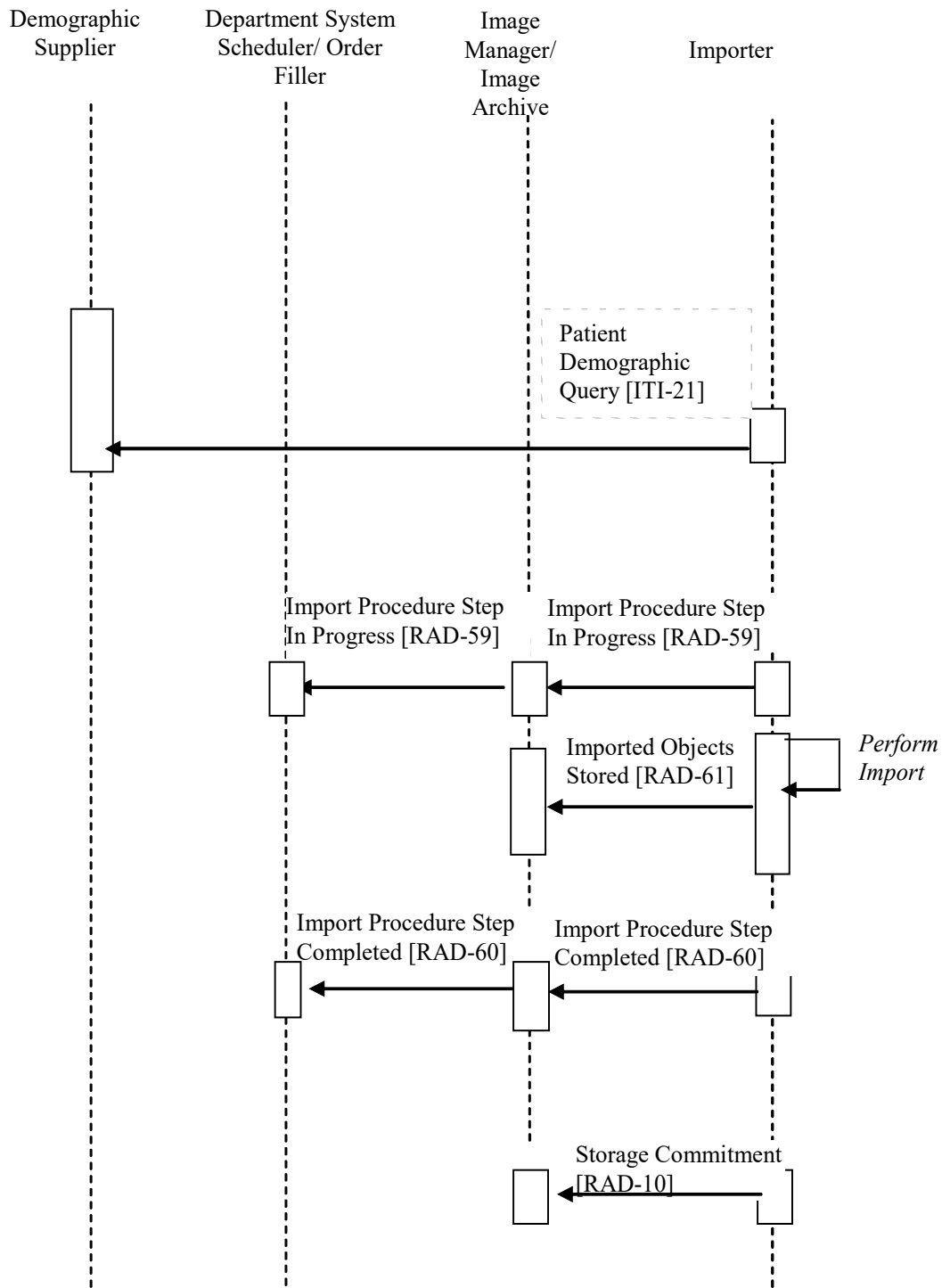

Figure 21.3.1-2: Unscheduled Import Reconciliation Workflow Process Flow

21.3.1.3.1 Unscheduled Import Data Reconciliation

4705 As part of the import process, the Importer reconciles the patient data as needed (e.g., to change the recorded Patient ID to the local Patient ID). The original DICOM object identifiers must be maintained in the imported DICOM Composite Objects in order to maintain the relationship of the Images within the Study (See RAD TF-2: Appendix A.5).

The policies of the importing enterprise will determine

- 4710
 - whether demographics from the Import Data can be used (e.g., Birth Dates, Patient Sex)
 - whether or how enterprise-specific codes in the imported data are coerced or ignored

21.3.2 Import Exception Management Workflow

4715 Exception management Workflow is required for Import Reconciliation Workflow. This case addresses the need to manage errors generated through the Import Reconciliation Workflow such as:

- Selection of the incorrect Scheduled Procedure Step from the Modality Worklist
- Selection of the incorrect Patient Demographics from the Patient Demographics List
- The inability to support the DICOM Composite Objects to be imported
- Equipment Failure
- 4720 • Bad media

Some of these exception cases are addressed using required functionality for IHE actors in the Import Reconciliation Workflow and Scheduled Workflow Profiles, while others make use of the IMPORT PPS EXCEPTION MANAGEMENT (See RAD TF-3: 4.60.4.1.2.2). The following numbered items list exception cases that shall be supported by the actors listed in each item.

4725 **22 Radiation Exposure Monitoring (REM) Integration Profile**

This integration profile specifies how details of radiation exposure resulting from imaging procedures are exchanged among the imaging systems, local dose information management systems and cross-institutional systems such as dose registries. The data flow in the profile is intended to facilitate recording individual procedure dose information, collecting dose data related to specific patients, and performing population analysis.

4730

Use of the relevant DICOM objects (CT Dose SR, Projection X-Ray Dose SR) is clarified and constrained.

The Profile focuses on conveying the details of individual irradiation events. A proper radiation exposure management program at an imaging facility would involve a medical physicist and define such things as local policies, local reporting requirements, annual reviews, etc. Although this Profile is intended to facilitate such activities, it does not define such policies, reports or processing, or in itself constitute a radiation exposure management program.

4735

The Profile addresses dose reporting for imaging procedures performed on CT and projection X-ray systems, including mammography. It does not currently address procedures such as nuclear medicine (PET or SPECT), radiotherapy, or implanted seeds.

4740

The Profile is intended to support quality assurance (QA) of the technical process (was the dose appropriate for the procedure performed). It is less suited to QA of the ordering process (was the procedure ordered/scheduled appropriate for the indications (appropriateness criteria)), or QA of the operational process (were any differences between the procedure scheduled and the procedure performed justified by the situation/equipment/patient and appropriately approved).

4745

Background

In the vast majority of medical procedures involving radiation, the potential benefit to the patients' health far outweighs the potential risk, but the trade-off should not be overlooked, and technological mechanisms can facilitate a conscious evaluation of that trade-off.

4750

Estimating radiation dose delivered to patients for medical purposes can facilitate a number of important activities:

- For facilities exposing patients to radiation, monitoring such exposures can help ensure their policies, procedures and protocols are adequate and being followed appropriately.
- For imaging physicians, monitoring such exposures can assist them in determining how changes in techniques and protocols impact radiation dose as well as image quality. This will enable them to maintain patient doses As Low As Reasonably Achievable (ALARA).
- For patients' physicians, overall data provided from monitoring such exposures can help them determine (in consultation with the imaging physician) if the benefit from the diagnostic information provided by an individual examination (or additional examinations) outweigh any small risk that may be associated with the imaging exam.

4755

4760

- For medical physicists, having such post-procedure information available for individual patients may help them make essential patient-specific dose estimates for pregnant patients or patients exhibiting skin erythema as a result of long fluoroscopy examinations.
- 4765
- For professional societies and regulatory agencies, a collection of exposure data can be useful when setting or reviewing radiation dose related guidelines and regulations. Many such groups have expressed a desire to establish standards of practice or dose reference levels based on a quantitative understanding of current practice, however they have found it prohibitively difficult to collect such data.
- 4770
- For physicists and physicians, this kind of data can be vital to answering some of the fundamental scientific questions that remain and developing a more detailed understanding of the health impacts of radiation exposure and how it should be measured and managed.

4775 However, it is important to understand the technical and practical limitations of such dose monitoring and the reasons why the monitored values may not accurately provide the radiation dose administered to the patient:

- The values provided by this tool are not “measurements” but only calculated estimates.
 - For computed tomography, “CTDI” is a dose estimate to a standard plastic phantom. Plastic is not human tissue. Therefore, CTDI should not be represented as the dose received by the patient.
- 4780
- For planar or projection imaging, the recorded values may be exposure, skin dose or some other value that may not be patient’s body or organ dose.
 - It is inappropriate and inaccurate to add up dose estimates received by different parts of the body into a single cumulative value.

4785 Despite such limitations, interest in monitoring radiation dose estimates is clearly expressed in such documents as the European directive Euratom 97/43 and the American College of Radiology Dose Whitepaper [1]. DICOM, with advice from the IEC, AAPM, ACR, NCRP and others, developed DICOM Dose objects appropriate for radiation dose monitoring

4790 By profiling automated methods of distribution, dose information can be collected and evaluated without imposing a significant administrative burden on staff otherwise occupied with caring for patients.

22.1 Actors/ Transactions

4795 Figure 22.1-1 shows the actors directly involved in the Radiation Exposure Monitoring Integration Profile and the relevant transactions between them. Other actors that may be indirectly involved due to their participation in other relevant transactions are not necessarily shown.

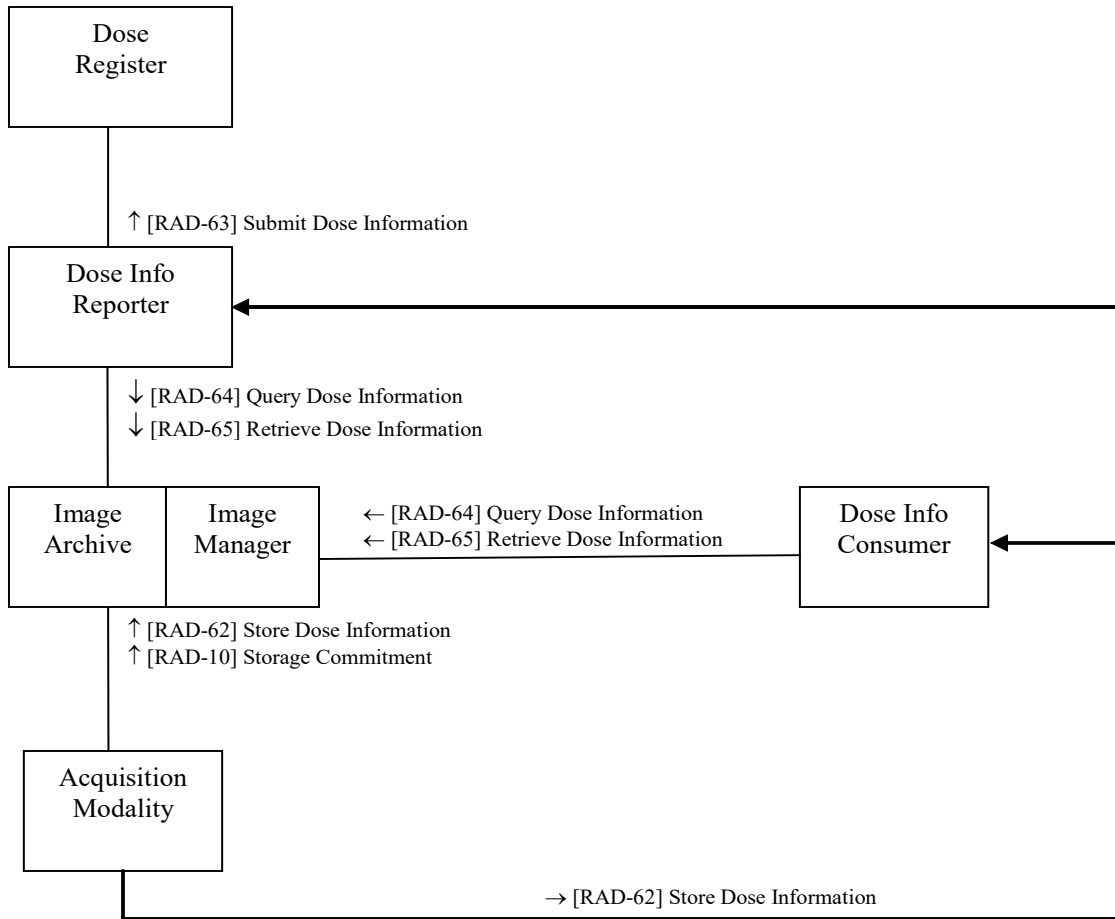

Figure 22.1-1: Radiation Exposure Monitoring - Actor Diagram

4800 Table 22.1-1 lists the transactions for each actor directly involved in the Radiation Exposure Monitoring Profile. In order to claim support of this integration profile, an implementation must perform the required transactions (labeled “R”). Transactions labeled “O” are optional. A complete list of options defined by this integration profile and that implementations may choose to support is listed in Section 22.2.

Table 22.1-1: Radiation Exposure Monitoring – Actors and Transactions

Actors	Transactions	Optionality	TF Reference
Acquisition Modality	Store Dose Information [RAD-62]	R	RAD TF-3: 4.62
	Storage Commitment [RAD-10]	R	RAD TF-2: 4.10
Image Manager/Archive	Store Dose Information [RAD-62]	R	RAD TF-3: 4.62
	Storage Commitment [RAD-10]	R	RAD TF-2: 4.10
	Query Dose Information [RAD-64]	R	RAD TF-3: 4.64
	Retrieve Dose Information [RAD-65]	R	RAD TF-3: 4.65

Actors	Transactions	Optionality	TF Reference
Dose Information Reporter	Query Dose Information [RAD-64]	R	RAD TF-3: 4.64
	Retrieve Dose Information [RAD-65]	R	RAD TF-3: 4.65
	Submit Dose Information [RAD-63]	R	RAD TF-3: 4.63
	Store Dose Information [RAD-62]	R	RAD TF-3: 4.62
Dose Information Consumer	Query Dose Information [RAD-64]	R	RAD TF-3: 4.64
	Retrieve Dose Information [RAD-65]	R	RAD TF-3: 4.65
	Store Dose Information [RAD-62]	R	RAD TF-3: 4.62
Dose Registry	Submit Dose Information [RAD-63]	R	RAD TF-3: 4.63

4805

An Acquisition Modality in this profile might not necessarily generate the irradiation itself. An Acquisition Modality may generate Dose objects on behalf of an irradiating modality system based on irradiation details obtained by manual input and/or some proprietary method, as long as it can do so completely and correctly.

4810

Actors are encouraged to describe in their DICOM Conformance Statement additional details of how they implement specific DICOM-based transactions (e.g., the time frame in which an Acquisition Modality is able to store a Dose object relative to the completion of the irradiation event).

22.2 Radiation Exposure Monitoring Integration Profile Options

4815

Options that may be selected for this integration profile are listed in the Table 22.2-1 along with the Actors to which they apply. Dependencies between options when applicable are specified in notes.

Currently there are no options defined in this profile.

Table 22.2-1: Radiation Exposure Monitoring – Actors and Options

Actor	Options	TF Reference
Acquisition Modality	<i>No options defined</i>	--
Image Manager/Archive	<i>No options defined</i>	--
Dose Information Reporter	<i>No options defined</i>	--
Dose Information Consumer	<i>No options defined</i>	--
Dose Registry	<i>No options defined</i>	--

4820

22.3 Radiation Exposure Monitoring Process Flow

This Profile addresses the flow of dose information from the source, through the organization and beyond. It does not mandate, but is intended to facilitate the ability to do things like:

- view the estimated dose a patient (or particular organs) received for a certain exam
- 4825 • determine if the estimated dose for a given procedure, system or physician regularly exceeds some reference level, policy trigger or is otherwise an "outlier" requiring further investigation
- compute the population "dose summary" for a specific exam in a certain hospital or region
- 4830 • compute the population "dose summary" for a certain pathology or indication
- compare exam-specific "dose summaries" against other sites/regions, against local policy targets or against standards of practice

4835 Note: To summarize dose for a specific exam type or pathology, the Dose Information Reporter needs to know such details for each dose object. IHE has required that such information be provided in the dose objects as coded values so they will be machine readable. If consistent codes are present in the dose objects, they can simply be sorted or mapped by a lookup table (See RAD TF-1 Appendix I.1.1 Code Set Management). Alternatively, a Dose Information Reporter might be grouped with a DSS/Order Filler so such details could be obtained for each Accession #. In either case, a critical task for sites wishing to do such analysis is to choose a set of codes for exam types and pathologies and to distribute and use them consistently across their systems.

4840 **22.3.1 General Case**

Typically, irradiation events occur on X-ray based imaging modalities, which record them in Dose objects that are part of the same study as the images and stored to the Image Manager/Archive.

4845 In many organizations, a Dose Information Reporter will collect Dose objects covering a particular period (e.g., today, this week or last month), analyze them, compare to site policy and generate summary reports.

All, or a sampled subset of the Dose objects might be submitted to a National Registry to facilitate composing population statistics and other research. Such Dose objects will generally undergo a configurable de-identification process prior to submission.

4850

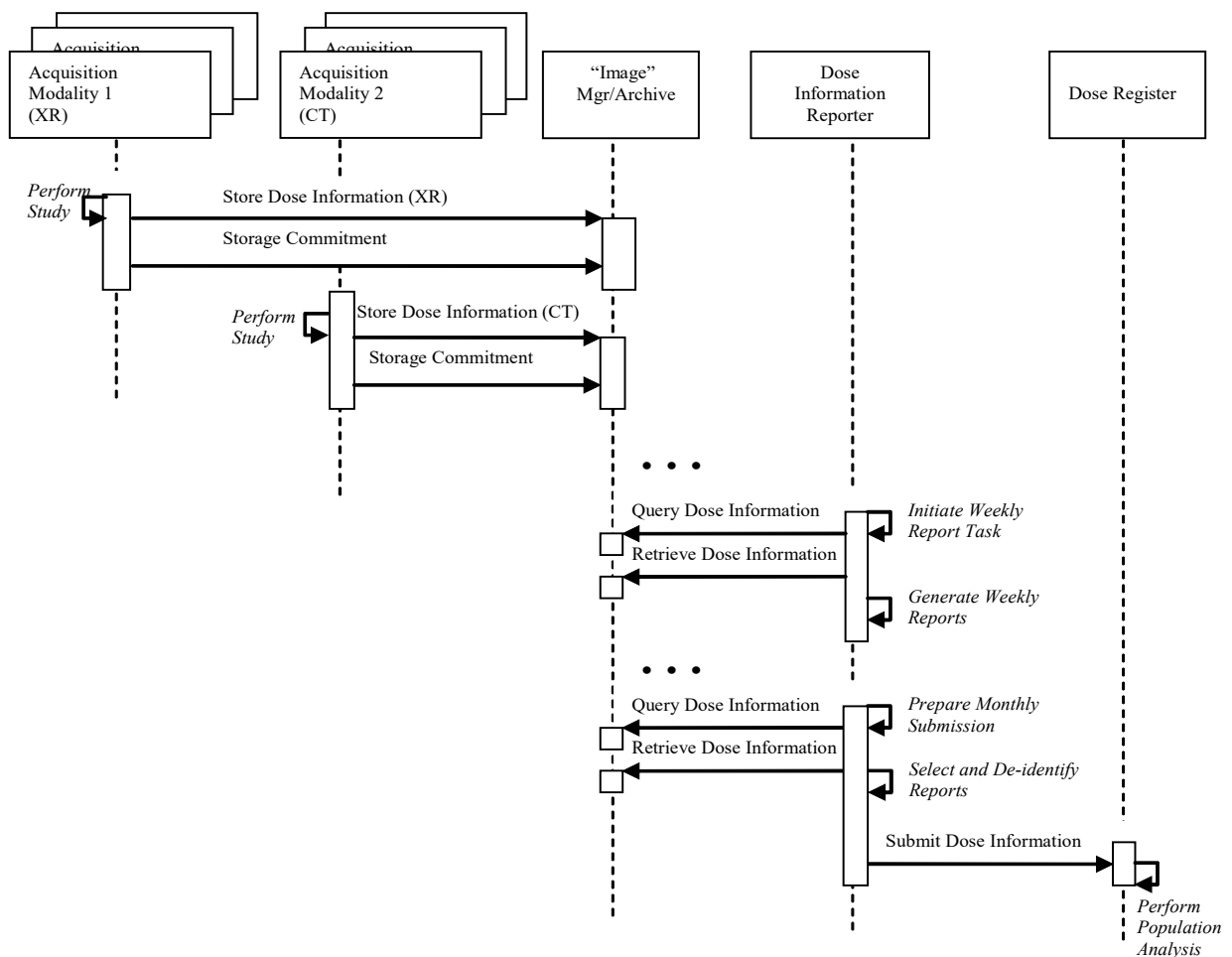

Figure 22.3-1: Radiation Exposure Monitoring – General Case

22.3.2 Real-World Use Cases

4855 To provide additional context for the General Case process flow, the following use cases describe real-world applications of the dose information.

Use Case: Department QA (Process Control)

Data will generally be continuously collected and evaluated on all procedures. Process control and data analysis would focus on local variations attributable to x-ray equipment, operators, procedures and ordering physicians. For example:

4860 As part of the departmental quality improvement program, the hospital’s medical physicist accesses the Dose Information Reporter to carry out his bi-monthly assessment of radiation dose. For a selected set of procedures, the dose-area product of each x-ray procedure is evaluated for each room. No significant variation of the average is found over the last 6 months. Another report compares average dose for different performing radiologists over

- 4865 several interventional procedures, and a third report compares performing technologists for CT and radiographic exams.
- It becomes clear that for a certain interventional procedure a newly arrived radiologist tends to generate 2 to 3 times the dose-area product of his colleagues, whose averages are in a narrow cluster well below the newcomer. While the dose-area product sub-total in
- 4870 fluoroscopy is similar among the radiologists (and is consistent with the average fluoroscopy time of the report), there is a significant discrepancy in dose-area product for the acquisition sub-total. The number of acquired images (higher than the departmental average) also corroborates this.
- The medical physicist writes a memo to the department chair, who raises the issue at the
- 4875 weekly radiologist meeting. Upon discussion, it becomes clear the radiologist uses a supplementary acquisition which his colleagues do not. After more discussion, the radiologists agree that the acquisition, although moderately useful, probably does not bring any information that would not be picked up in the rest of the exam, and it is agreed it should not be done. The medical physicist reviews the situation a month later, and is reassured that
- 4880 the results show all radiologists now have similar dose-area product for that procedure.
- Hospitals generally have policies relating to patient radiation dose, often benchmarking performance estimates against published reference levels. Policies (and reference levels) are often broken down by procedure, patient age group, and perhaps weight group, or gender.
- Analysis tools can help sites monitor whether policies are being followed, and measure progress
- 4885 toward improvement targets. While image quality generally sets the low side limit on dose (too low and the images are unacceptable to the radiologists), QA programs can be an effective way to counter dose creep, establish upper trigger levels and encourage lower values.
- Use Case: Patient Impact Evaluation**
- A few days after a CT exam is carried out for a young female patient, the referring physician
- 4890 identifies the patient as pregnant (which was not known at the time of the scan). The referring physician requests an evaluation of the risk to the fetus from the radiologist who read the exam. The radiologist requests a hospital medical physicist to provide an estimate of the radiation dose received by the uterus in the course of the CT exam.
- The medical physicist retrieves the images and dose data for the study in question, and
- 4895 determines with the help of the radiologist which series encompass the uterus. Knowing which series are of interest, the medical physicist is then able to leverage the dose indicators and weight of the patient contained in the dose and image objects to estimate the total dose to the uterus.
- How the information is recorded and distributed will vary, but in this particular hospital, the dose estimate is then provided to the clinical coordinator of the department, who enters it in the RIS,
- 4900 appending a statement to the report (which had already been signed off), and demoting the status of the study to "pending signature". Before signing off the report, the radiologist completes the addendum with her estimate of the risk to the fetus given the dose measurement, and communicates this result by phone to the referring physician, who also receives the written addendum electronically signed by the radiologist a few days later.

4905 Important analysis details include time/date of scans, body area irradiated, exposure values.

Use Case: Population Dose and Dose Indicators

4910 Organizations wishing to assess Population Dose and Dose Indicators will often set up a Dose Registry. A sampling of dose estimates with reasonable accuracy are collected from a number of clinical sites, often for specific targeted procedures. It is not necessary that every procedure performed be collected; a representative sample of procedures is sufficient. That being said, it may be easier for a dose registry to discard a portion of the procedures submitted than to try and get each submitting site to follow the same regimen for selecting procedures to submit.

Note that conversion of estimated dose values to patient or population risk involves complex scientific questions. Streamlining the collection of additional, more detailed data can only help.

4915 For further discussion, see RAD TF-1: Appendix I – Deployment of Dose Registries.

Use Case: Dose Reference Levels

Quantitative Dose Guidelines are often distributed in the form of Dose Reference Levels for typical procedures for groups of patients of different characteristics (e.g., a target dose level to stay below for adult head studies).

4920 Such guidelines are often the logical result of analyzing Population Dose or other data mining performed by a professional society or regulatory body.

Use Case: Site Benchmarking

4925 Imaging facilities may find it useful to compare their dose profile by modality, exam type, and pathology to other facilities of the same type, facilities in the same region, and to the nation as a whole. A national radiation dose registry might provide facilities submitting data with reports comparing them to regional and national benchmarks.

Use Case: Population Epidemiology

4930 To analyze certain population epidemiology questions, e.g., the occupational hazards of being a radiologist, one has patients with a known disease and would like to use the patients' radiation history to estimate the likelihood of radiogenic etiology. Requirements include access to a complete radiation history of each such patient. Because of long latent periods, data must be archived in a manner that makes it both physically readable and dosimetrically intelligible years, or decades, after it is written.

Use Case: Clinical Trials

4935 The radiation dose can be an important component of a clinical trial. For example, a trial of a proposed low-dose CT lung screening procedure would benefit from being able to collect dose data to balance against the resulting detection rates for a proper trade-off analysis. Co-submission of image and Dose objects could facilitate this.

Use Case: Procedure Operational Awareness (Quasi-realtime)

4940 Some regulations already require that $K_{a,r}$ be displayed on fluoroscopy systems within sight of the primary operator. This permits the operator to factor radiation effects into the continuous clinical benefit-risk analysis occurring during any procedure (keeping in mind that $K_{a,r}$ is not the same as cumulative skin dose). Such direct display can be handled by the modality and has no need of the transactions provided by this profile

4945 **Use Case: Clinical Management**

Dose estimates and dose estimate maps can facilitate planning for subsequent procedures (such as deciding how much time to allow for tissue to heal, or deciding what direction to image from to avoid damaged tissues). Particularly for interventional fluoroscopy, the dose distribution delivered by each procedure should be part of the patients' medical record.

4950 **Use Case: Longitudinal Patient Dose Record**

The lifetime radiation dose received by a patient can be stored and retrieved from a longitudinal record, whether it is stored as part of the entire patient history, or as a separate entity. This may in future form a vital source of information for clinical decision-making with respect to the appropriateness and risk of an additional procedure, as well as remediation in the event of an unfortunate outcome. As methods evolve for estimating effective dose to radio-sensitive tissues and quantifying cancer risk, these can be retrospectively applied to stored dose information. This use case is distinct from registry use cases, since the goal is to track the individual, rather than population, dose. It is distinct from the Clinical Management use case, since it spans a longer term, multiple episodes of care and multiple sites.

4960 This use case necessarily requires support of acquisition and collation of dose information from multiple acquisition sites, since a patient may be provided healthcare at many sites over their entire life time.

22.3.3 Example REM Profile Deployments

4965 These examples are intended to illustrate a few ways the Radiation Exposure Monitoring Profile might be deployed inside a hospital or clinic. It is not intended to be normative, or to show all possible deployments. Further practical examples related to the use of a Registry appear in Appendix I.

22.3.3.1 A Hospital Scenario

4970 The Radiology PACS would perhaps implement the Image Manager/Archive in this profile and also the PIR, SWF Profiles.

The RIS might implement the Dose Information Reporter in this profile and be grouped with a DSS/Order Filler supporting the SWF and PIR Profiles.

A Dose Mapping Workstation might implement both the Dose Information Consumer (to obtain Dose objects) and the Evidence Creator (to submit new ones).

4975 Perhaps Cardiology has a separate PACS which also implements an Image Manager/Archive for the cardiology modalities. The Dose Information Reporter (in the Radiology RIS) could query both Archives and manage dose for the hospital in one place.

22.3.3.2 An Imaging Clinic Scenario

Many imaging clinics will have a PACS and could follow a similar layout to the Hospital above.

4980 Alternatively, a PACS-less clinic which decides they do not need long term archiving or reconciliation of the Dose objects might not have an Image Manager/Archive.

The Office Management System or a standalone workstation could implement the Dose Information Reporter, and takes advantage of its ability to receive Dose objects directly from the local modalities.

4985 22.3.3.3 A Longitudinal Patient Record Scenario

Multiple sites, including hospitals and imaging clinics, implement Acquisition Modalities and/or Image Manager/Archives that provide information in response to queries from a local Dose Information Reporter.

4990 The local Dose Information Reporter transmits identifiable (as opposed to de-identified) dose information to a remote Dose Register nominated by the patient to act as their lifetime repository of longitudinal dose information. Each local site may use different forms of the patient's name and different domains for patient identifier, and accordingly the Dose Information Reporter should include multiple identifiers for different domains, and/or regional or national identifiers, if known, and the Dose Register may need to be grouped with a PIX Manager or similar
4995 mechanism to resolve identities. See also the issues raised in the Multiple Image Manager/Archive (MIMA) Trial Implementation supplement.

If the remote Dose Register is grouped with its own Dose Information Reporter Actor, then given the appropriate authorization by the patient, another local site with a Dose Consumer Actor may access the information to make clinical decisions.

5000 Additionally, if remote Dose Register and/or Dose Information Reporter is also capable of modeling effective dose using organ segmentation information, it may want to receive and store the images reconstructed from the irradiation events described in the dose objects, and hence to be grouped with a remote Image Manager/Archive Actor.

22.4 Radiation Exposure Monitoring Profile Security Considerations

5005 Dose Objects have the same security considerations as images.

Security and Privacy policies may require the de-identification of some or all of the PHI details prior to the submission or use of Dose Objects (see RAD TF-3: 4.63.4.1.2.1). De-identification behavior may need to vary by destination due to differences in PHI exposure risk and the need to retain some details, such as approximate patient age or weight, when performing Radiation Dose
5010 analysis.

22.5 Relation to Other Profiles

Several synergies and interactions of the Radiation Exposure Monitoring Profile with other profiles are specifically called out here.

22.5.1 Radiology Profiles

5015 **22.5.1.1 Portable Data for Imaging (PDI)**

The Dose objects from this profile may be included on PDI media, either along with the rest of the study data to provide a “complete package”, or on their own as a way of conveying Dose objects to a patient, another organization or a dose registry.

22.5.1.2 Patient Identification Reconciliation (PIR)

5020 An Image Manager/Archive which also implements the Patient Identification Reconciliation Profile is expected to reconcile the Dose objects along with the rest of the DICOM objects in a patients’ study. This is highly desirable.

22.5.1.3 Teaching Files and Clinical Trials Export (TCE)

5025 As DICOM objects, the Dose objects can be referenced in a TCE manifest and processed along with other objects from a study. This could allow submitting dose details in clinical trials where such information is relevant, or including dose details in a teaching file, perhaps one specifically addressing protocol dose and the effects on image quality.

22.5.2 ITI Profiles

22.5.2.1 Patient Identity Cross-referencing (PIX)

5030 The PIX Profile could clearly be useful if there is a need to collate patient dose records across multiple Patient ID Domains. It could also be useful if a single Dose Information Reporter is querying multiple Image Manager/Archives in different Patient ID Domains.

22.5.2.2 Cross-Enterprise Document Sharing (XD*)

5035 Since Dose objects are normal DICOM SR objects, the collection of XDS Profiles (XDS, XDS-I, XDR, XDM, etc.) can be used to distribute or access dose records across multiple sites.

22.5.2.3 Consistent Time (CT)

Consistent Time is particularly useful if a gantry and reader are trying to compose a Dose object by synchronizing study details based on timestamps.

22.5.2.4 Audit Trail and Node Authentication (ATNA)

5040 Audit events relevant to the transactions of the REM Profile are identified in RAD TF-3: Table 5.1-2 in the Radiology Audit Trail Option.

23 Mammography Acquisition Workflow (MAWF)

This section intentionally, temporarily left blank.

5045 **24 MR Diffusion Imaging (DIFF)**

This section intentionally, temporarily left blank.

25 CT/MR Perfusion Imaging with Contrast (PERF)

This section intentionally, temporarily left blank.

26 Basic Image Review (BIR)

5050 This section intentionally, temporarily left blank.

27 Chest X-Ray CAD Display (CXCAD)

This section intentionally, temporarily left blank.

28 Imaging Object Change Management (IOCM)

- 5055 The Imaging Object Change Management Integration Profile (IOCM) specifies how one actor communicates local changes applied on existing imaging objects to other actors that manage copies of the modified imaging objects in their own local systems. The supported changes include (1) object rejection due to quality or patient safety reasons, (2) correction of incorrect modality worklist entry selection, and (3) expiration of objects due to data retention requirements. It defines how changes are captured and how to communicate these changes.
- 5060 IHE Scheduled Workflow Profile defines an PPS Exception Management Option (RAD TF-1: 3.3.4 and RAD TF-2: 4.7.4.1.3.1) which specifies how to correct the incorrectly selected worklist entry after the Modality Performed Procedure Step In Progress transaction has been issued but before the Modality Performed Procedure Step Completed transaction is issued. This Imaging Object Change Management Profile addresses the use case in which the incorrect modality
- 5065 worklist selection is detected after the Modality Performed Procedure Step Completed transaction is issued.

The required workflow steps for the DSS/OF and the actors grouped with Change Requester are specified in the Scheduled Workflow Profile.

28.1 Actors/ Transactions

- 5070 Figures 28.1-1 shows the actors directly involved in the Imaging Object Change Management Integration Profile and the relevant transactions between them. Other actors that may be indirectly involved due to their participation in Scheduled Workflow, Consistent Presentation of Images, etc. are not necessarily shown.

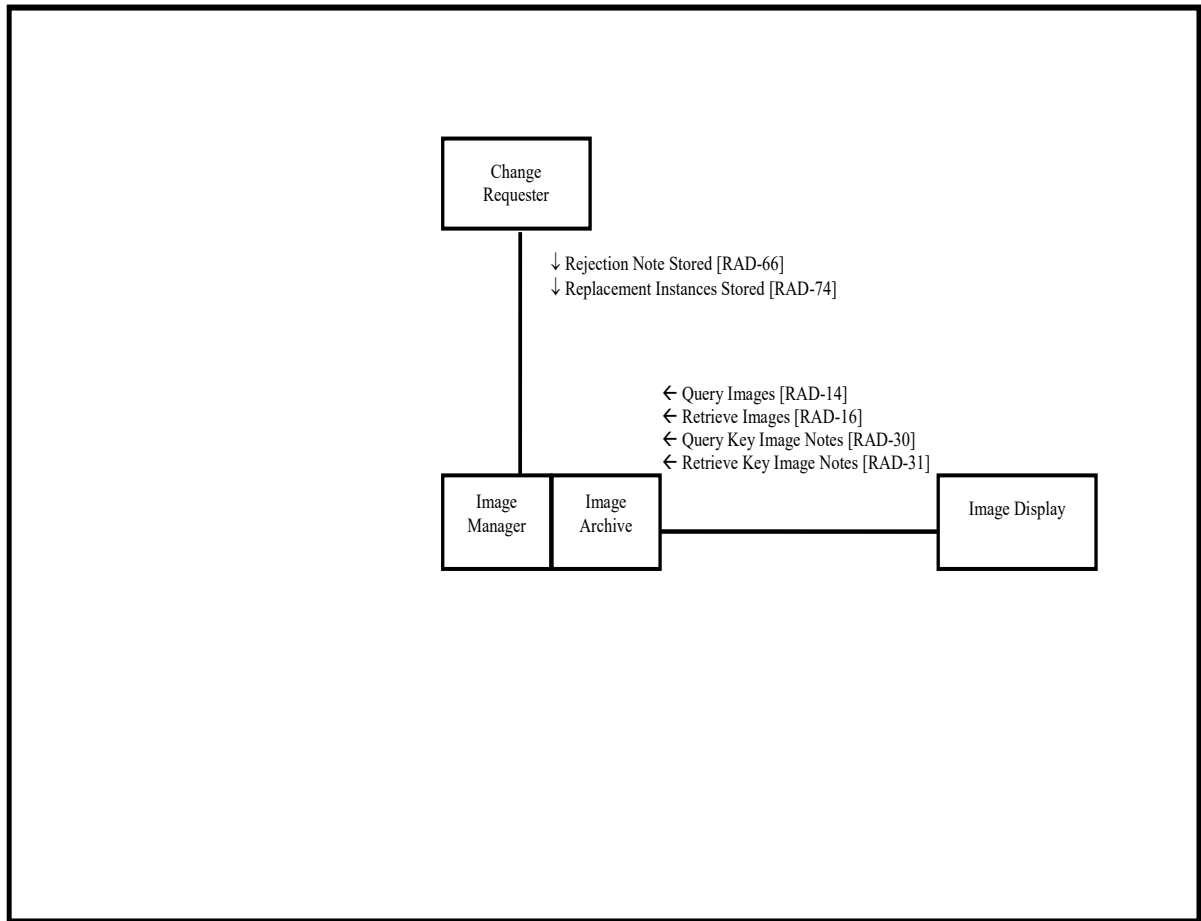

5075

Figure 28.1-1: Imaging Object Change Management Actor Diagram related to SWF

5080

Table 28.1-1 lists the transactions for each actor directly involved in the Imaging Object Change Management Profile. In order to claim support of this integration profile, an implementation must perform the required transactions (labeled “R”). Transactions labeled “O” are optional. A complete list of options defined by this integration profile and that implementations may choose to support is listed in Section 28.2.

Table 28.1-1: Imaging Object Change Management Integration Profile - Actors and Transactions

Actors	Transactions	Optionality	TF Reference
Change Requester	Rejection Note Stored [RAD-66]	R	RAD TF-3: 4.66
	Replacement Instances Stored [RAD-74]	R	RAD TF-3: 4.74
Image Manager / Archive	Rejection Note Stored [RAD-66]	R	RAD TF-3: 4.66
	Replacement Instances Stored [RAD-74]	R	RAD TF-3: 4.74
Image Display	Query Images [RAD-14]	R	RAD TF-2: 4.14
	Retrieve Images [RAD-16]	R	RAD TF-2: 4.16
	Query Key Image Notes [RAD-30]	R	RAD TF-2: 4.30

Actors	Transactions	Optionality	TF Reference
	Retrieve Key Image Notes [RAD-31]	R	RAD TF-2: 4.31

28.2 Imaging Object Change Management Integration Profile Options

5085 Options that may be selected for this integration profile are listed in the Table 28.2-1 along with the Actors to which they apply. Dependencies between options when applicable are specified in notes.

Table 28.2-1: Imaging Object Change Management - Actors and Options

Actor	Options	TF Reference
Change Requester	<i>No option defined</i>	-
Image Manager / Archive	<i>No option defined</i>	-
Image Display	<i>No option defined</i>	-

5090 28.3 Imaging Object Change Management Integration Profile Actor Groupings and Profile Interactions

Imaging Object Change Management builds upon the underlying Actor transactions defined in other Profiles. For this reason, certain IOCM Profile actors shall be grouped with actors from other Profiles as defined in Table 28.3-1.

5095 **Table 28.3-1: Imaging Object Change Management Integration Profile - Actors and Transactions**

Integration Profile	Actor	Grouped With		Comments
		Profile	Actor	
Imaging Object Change Management	Change Requester (see Note 1)	Scheduled Workflow	Acquisition Modality	Support communication of procedure steps and storage commitment when Change Requester is grouped with Acquisition Modality, Image Manager/Image Archive or Evidence Creator.
		Scheduled Workflow	Evidence Creator	
		Scheduled Workflow	Image Manager/Image Archive	

Integration Profile	Actor	Grouped With		Comments
		Profile	Actor	
	Image Manager/ Image Archive	Scheduled Workflow	Image Manager/ Image Archive	Support Image Manager to Image Manager change management if Multiple Patient Identity Resolution Option is supported.
	Image Display	Scheduled Workflow	Image Display	SWF defines message semantics for query-retrieval
	Change Requester (see Note 1)	Patient Information Reconciliation	Acquisition Modality	PIR defines the patient information reconciliation mechanisms that shall be supported by these actors. IOCM shall not be used as an alternative mechanism for handling patient information reconciliation use cases.
		Patient Information Reconciliation	Image Manager/ Image Archive	
	Image Manager/ Image Archive	Patient Information Reconciliation	Image Manager/ Image Archive	

Note 1: At least one of the optional retrieve transactions is required to be supported. Refer to Section 18.4 for additional requirements on the Imaging Document Consumer.

28.4 Imaging Object Change Management Process Flow

5100 Imaging Object Change Management covers the following use cases:

- Data Retention Expiration
- Correction or Rejection of imaging instances for Quality Reasons
- Correction or Rejection of imaging instances for Patient Safety Reasons
- Correction of Modality Worklist Selection

5105 The following use cases generally apply to all imaging objects as well as non-imaging objects including Grayscale Softcopy Presentation State (GSPS), Key Object Selection Document (KOS), Structured Report (SR), etc. although the examples may focus on the images themselves for simplicity.

5110 The start and completion of creating Rejection Notes, and Replacement Instances if necessary, are reported as Procedure Steps In-Progress/Completed by the relevant IHE workflow actor that has been grouped with the Change Requester (either an Acquisition Modality or an Evidence Creator).

The Procedure Step transactions, Storage Commitment transaction, Query Modality Worklist transaction and the Query/ Retrieve Images transactions in the following diagrams are part of

5115 Radiology Scheduled Workflow as an example IHE Workflow Profile. They are not part of the Imaging Object Change Management Profile and are only included in the diagrams for illustration.

Note: There are existing profiles defined in the Radiology Technical Framework that are also designed to manage changes in different aspects of imaging objects (e.g., Patient Information Reconciliation, Import Reconciliation Workflow, etc.) Vendors should continue to follow those integration profiles for their respective use cases.

28.4.1 Use Case: Data Retention Expiration

Instances may be deleted to comply with data retention policies.

- 5125 • A local Image Manager / Archive, supporting the Multiple Identity Resolution Option in IHE Scheduled Workflow Profile, stores instances to a centralized Image Manager / Archive for long term storage using the Image Manager Instances Stored [RAD-70] transaction (current in the IHE RAD Multiple Image Manager Archive (MIMA) Trial Implementation Supplement).
- Later, according to the data retention policy of the local Image Manager / Archive, selected studies are deleted internally.
- 5130 • The local Image Manager / Archive has implemented the Change Requester Actor of the IOCM Profile to communicate these changes to the centralized Image Manager / Archive.
- The local Image Manager / Archive, as an IOCM Change Requester, creates a Key Object Selection (KOS) instance with a Selection Document Title of “Data Retention Policy Expired” that lists the deleted instances, and sends this to the centralized Image Manager / Archive using the Rejection Notes Stored [RAD-66] transaction, followed by the Image Manager Storage Commitment [RAD-71] transaction (in the MIMA Supplement).
- 5135 • The centralized Image Manager / Archive receives the deletion requests and deletes the referenced studies accordingly.
- 5140 The healthcare provider is responsible for drafting and implementing appropriate data retention policies (see Section 28.4).

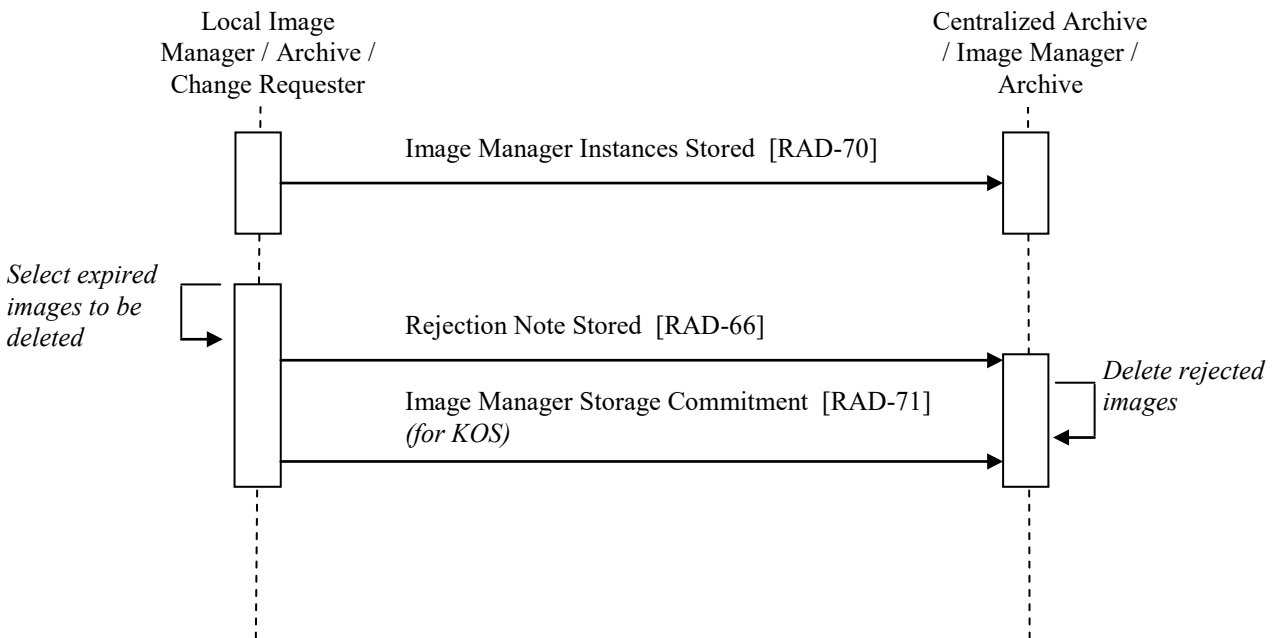

5145

Figure 28.4.1-1: Process Flow for handling expired studies

28.4.2 Use Case: Image Rejection for Quality Reasons

5150 Instances may be deleted for quality reasons. The Change Requester may be grouped with an Acquisition Modality Actor, an Evidence Creator Actor, or an Image Manager / Archive Actor, depending on whether such QA happens on the modality, a separate workstation, or an image manager.

5155 **Clinical aspect:** The Technologist or Radiologist decides that certain images are not useful for clinical use, e.g., due to patient motion. While correcting image acquisition context data on a Modality application, e.g., during quality control, the Technologist wants to mark these images as "rejected" so that other systems correctly handle the rejected images according to local policies. The procedure step has already been completed, and all images, including the rejected images, have been stored to the Image Manager / Archive.

5160 Site policies may determine if rejected images will be presented to users on later retrieval or not, as they may be of clinical relevance or for quality control monitoring. The Image Manager / Archive gets all images as well as change information, and then applies internal rules to fulfill site policies.

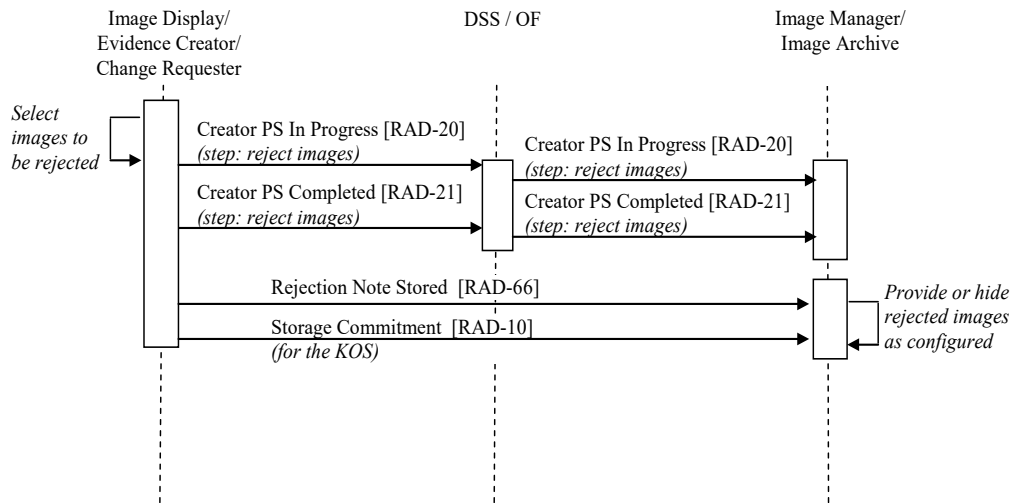

Figure 28.4.2-1: Process Flow for handling rejected images

5165 **Technical aspect:** A user marks certain images of insufficient quality as "Rejected for Quality
Reasons" and selects a reason. The Evidence Creator, as a Change Requester, creates a Key
Object Selection (KOS) instance that references the rejected images with a Selection Document
Title of "Rejected for Quality Reasons" and the reason. It creates a Creator PPS [RAD-20], sets
it COMPLETED (including a reference to this KOS) and sends it to the DSS/OF [RAD-21]. It
5170 also stores the KOS to the Image Manager / Archive [RAD-66], and then uses the Storage
Commitment [RAD-10] transaction.

The Image Manager / Archive can be configured to provide such rejected images or to hide them
from subsequent query/ retrieve responses. An Image Display, when receiving a "Rejected for
Quality Reasons" KOS, will display the images and / or KOS, or will hide both ([RAD-16], per
configuration).

5175 **Variants:** Instead of an Evidence Creator being the Change Requester, an Image Manager is the
Change Requester. The only difference will be that the Image Manager acting as the Change
Requester does not have to create an MPPS referencing the Rejection Note or an MPPS
referencing the corrected images.

28.4.3 Use Case: Image Correction for Patient Safety Reasons

5180 Instances may be corrected (deleted and replaced) for patient safety reasons. The Change
Requester may be grouped with an Acquisition Modality Actor, an Evidence Creator Actor, or an
Image Manager/Archive, depending on whether such QA happens on the modality, a separate
workstation, or an image manager.

5185 **Clinical aspect:** The Technologist takes a left breast cranial caudal view (LCC), and didn't
realize that the defaults were set for a right breast (RCC) view, thus the view is labeled
incorrectly. The acquisition has been set completed and images were sent to the PACS.

The Technologist wants to correct this view information at the Acquisition Modality or at the
nearby Quality Control Workstation (e.g., view code, view description, patient orientation,

5190 laterality) and "update" the images in the PACS. For correct interpretation and diagnosis, the Radiologist depends on a correct view labeling. Incorrectly labeled views may confuse CAD processing, and may also disturb proper display and navigation of images at a workstation. This is a patient safety issue; the incorrect image does not provide additional clinical information but may be harmful, so it is not to be used any more.

The RIS may be notified about such changes, e.g., for logging or informing a user.

5195

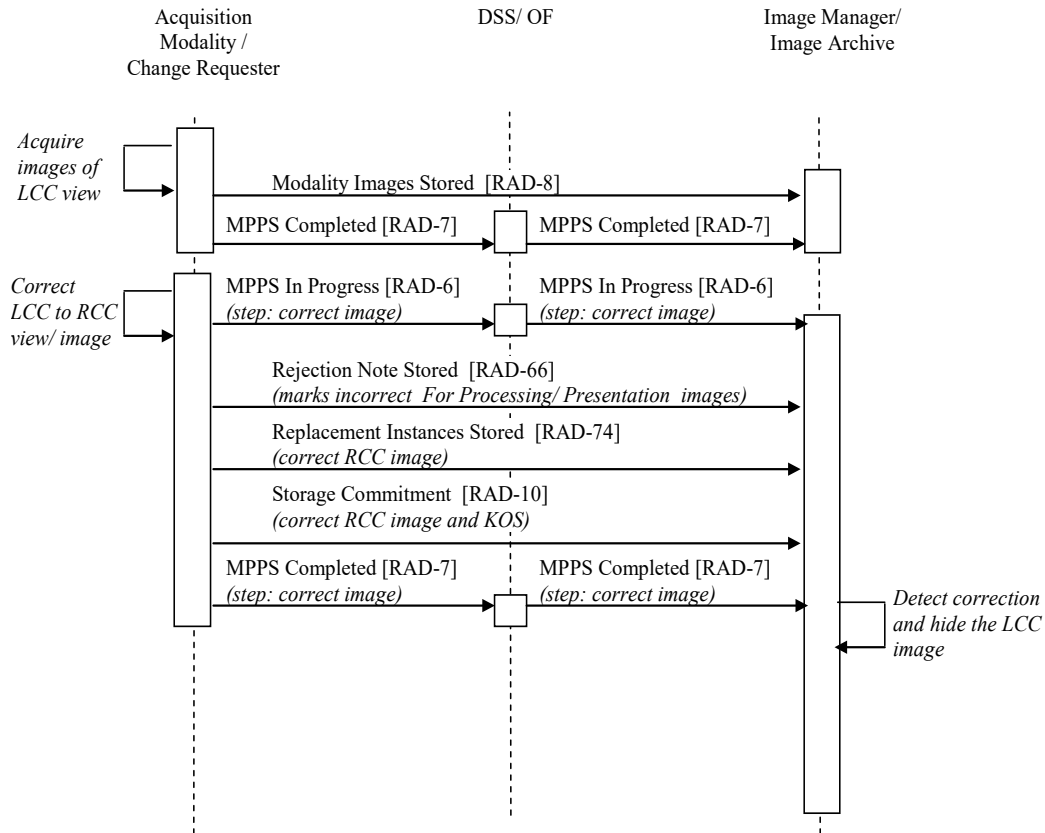

Figure 28.4.3-1: Process Flow for correction of image labeling

5200 **Technical aspect:** The Acquisition Modality, as a Change Requester, creates and stores a Key Object Selection (KOS) with a Selection Document Title of “Rejected for Patient Safety Reasons” that lists the incorrect instances and sends this using Rejection Note Stored [RAD-66]. It creates corrected images and stores them [RAD-74]. It also creates a Modality PS [RAD-6], sets it COMPLETED (including references to both the corrected images and this KOS), and sends it to the DSS/OF [RAD-7].

5205 The Image Manager/Archive, as a consequence of receiving the KOS, hides the incorrect images from subsequent query/retrieve. An Image Display, when receiving a KOS with a Selection Document Title of “Rejected for Patient Safety Reasons”, does not display the KOS and its referenced images [RAD-16].

5210 **Variation:** Instead of an Acquisition Modality being the Change Requester, an Image Manager is the Change Requester. The only difference will be that the Image Manager acting as the Change Requester does not have to create an MPPS referencing the Rejection Note or an MPPS referencing the corrected images.

28.4.4 Use Case: Object Correction due to Modality Worklist Selection Error

5215 **Clinical aspect:** A patient arrives at the hospital for a scheduled procedure. The Technologist selects a modality worklist entry for the procedure to be performed but mistakenly selects the wrong entry. The Technologist completes the acquisition step.

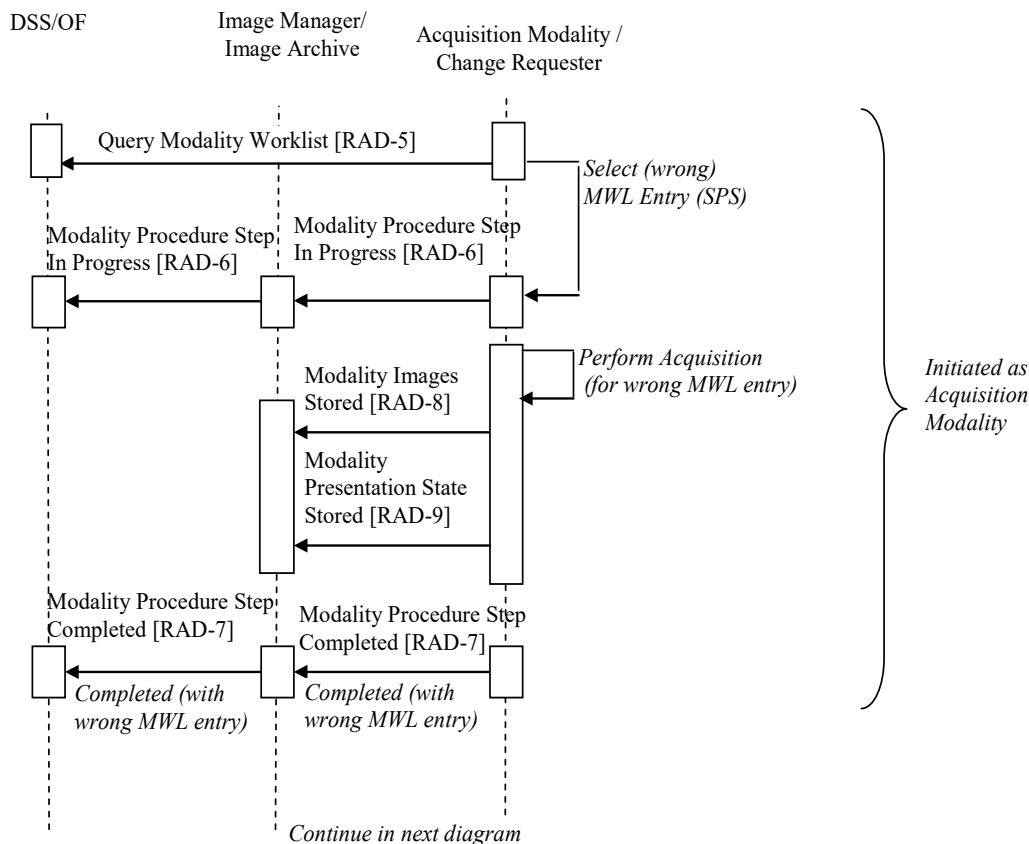

Figure 28.4.4-1: Exception Management Workflow (Incorrect Worklist Entry Selected)

Note: Storage Commitment [RAD-10] is not shown in the diagrams above only for simplification of the diagrams.

5220

Later, the Technologist or Radiologist identifies that patient or order information is incorrect for the whole study. At this point there are two alternative scenarios that can follow:

1. The originally acquired images are relevant to the originally scheduled procedure for the correct patient.

- 5225 2. The originally acquired images are not relevant to the originally scheduled procedure for the correct patient.

Regardless of which scenario occurs, if additional images need to be acquired for the actual scheduled procedure for the correct patient, then acquisition of the new images shall be performed according to Scheduled Workflow.

- 5230 The first scenario is illustrated in Figure 28.4.4-2; the Technologist determines that the acquired images are relevant to the actual scheduled procedure for the correct patient. In this case the Technologist matches the originally acquired images against the originally scheduled procedure for the correct patient using Quality Control tools provided by the Modality.

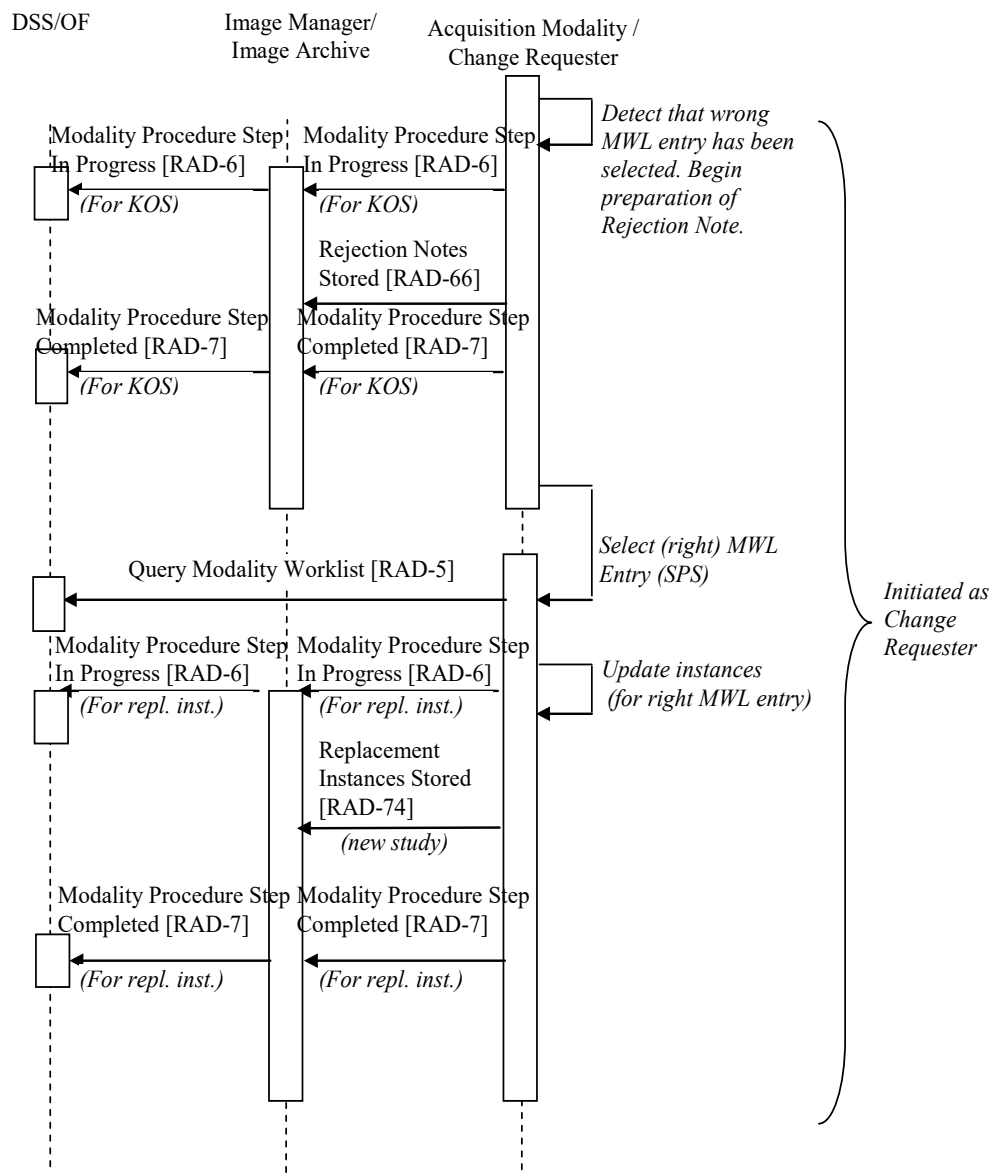

5235

Figure 28.4.4-2: Acquired Images are Relevant to Correct Procedure

Note: Storage Commitment [RAD-10] is not shown in the diagrams above only for simplification of the diagrams.

5240 The alternative scenario is that the Technologist determines that the originally acquired images are not relevant to the actual scheduled procedure for the correct patient. This could be handled in two different ways:

1. The originally acquired images are handled by the Technologist as an unscheduled case.
- 5245 2. A new procedure is scheduled for the correct patient on the DSS/OF and the originally acquired images are updated to correspond to the new scheduled procedure obtained from the Modality Worklist.

Figure 28.4.4-3 illustrates the correction of the images as an unscheduled case.

5250 The alternative approach of scheduling a new procedure on the DSS/OF is not illustrated here. It would follow the normal Scheduled Workflow sequencing with the exception that rather than acquiring new images, the originally acquired images would be updated to correspond to the new scheduled procedure obtained from the Modality Worklist.

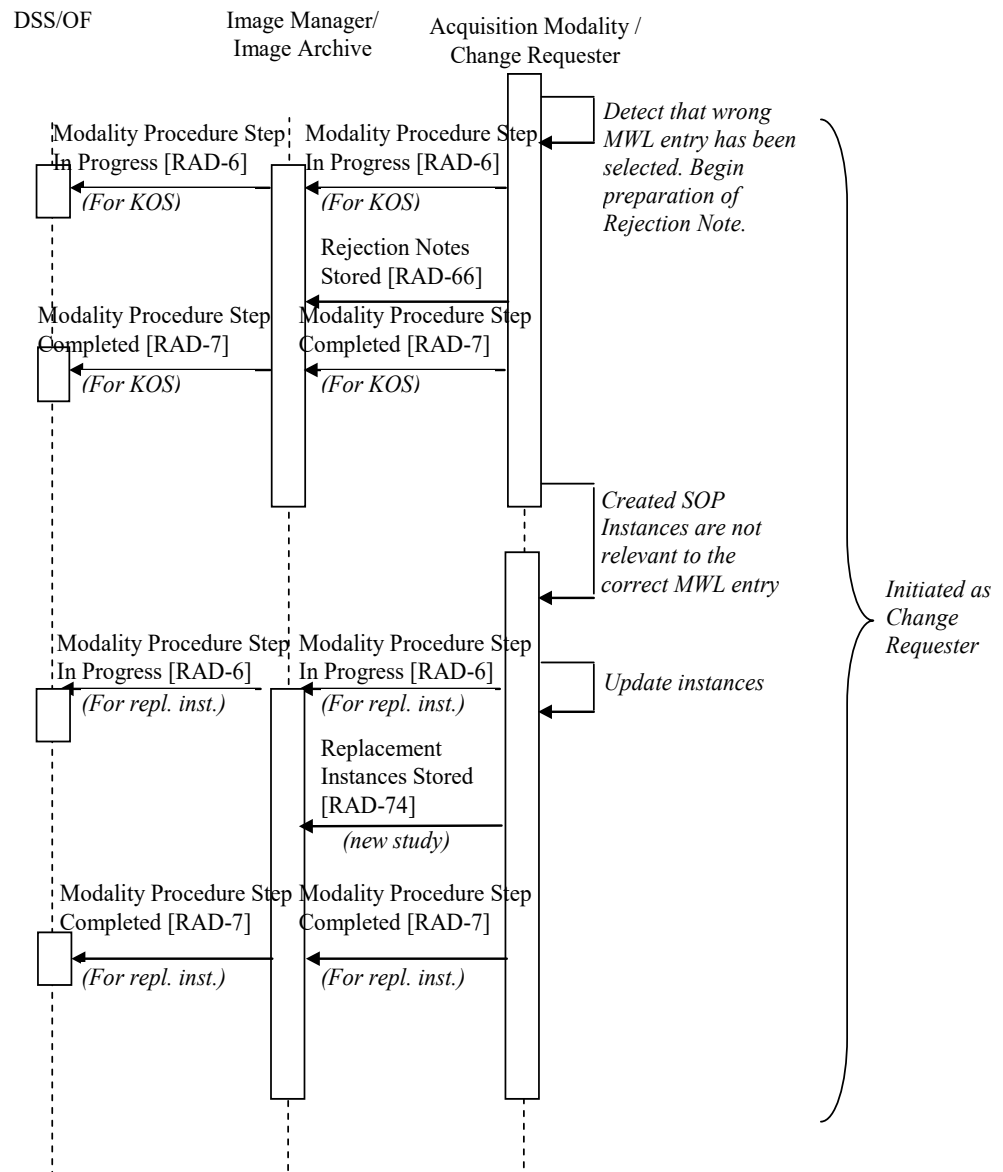

Figure 28.4.4-3: Acquired Images are Not Relevant to Correct Procedure and are Handled as an Unscheduled Case

Note: Storage Commitment [RAD-10] is not shown in the diagrams above only for simplification of the diagrams.

5255

Technical aspect: The Acquisition Modality creates the originally acquired images with their headers set to the information from the incorrectly selected modality worklist entry. It creates a corresponding MPPS [RAD-6], completes and sends it [RAD-7], and stores the images to the Image Archive [RAD-8] (see Figure 28.4.4-1).

5260

Later, the Technologist or the Radiologist detects the mistakes (see Figure 28.4.4-2). The Acquisition Modality, as a Change Requester, sends a Rejection Note [RAD-66] KOS which

5265 contains references to the rejected SOP instances, the originally acquired images, to the Image Manager. It also creates a MPPS [RAD-6] referencing this Rejection Note, completes the MPPS with the reference to the KOS and sends it to the Image Manager / Archive and DSS/OF [RAD-7]. The Image Manager receives the Rejection Note and makes all the referenced SOP instances unavailable.

The technical aspects then vary depending upon whether or not the originally acquired images are relevant to the actual scheduled procedure for the correct patient.

5270 If it is determined that the originally acquired images are relevant to the actual scheduled procedure for the correct patient then the Acquisition Modality selects the correct modality worklist entry [RAD-5] and updates the originally acquired images (while the study is still available at the Acquisition Modality without re-acquisition) with the correct information. The corrected images are assigned new SOP Instance UIDs so that they can be distinguished from the originally acquired images which have already been exported. If the correct modality worklist entry is not readily available, the Acquisition Modality queries the DSS/OF again, as illustrated in Figure 28.4.4-2. In order to communicate the corrected images to other systems, the Acquisition Modality, as a Change Requester, creates a new MPPS with the correct information from the modality worklist [RAD-5]. It then stores the new set of corrected images to the Image Manager [RAD-74], and completes the MPPS and sends it [RAD-7].

5280 Alternatively, if it is determined that the originally acquired images are not relevant to the actual scheduled procedure for the correct patient then the Acquisition Modality either handles the images as if they belong to an unscheduled procedure, or a new procedure for the acquired images is entered on the DSS/OF. If treated as an unscheduled case as shown in Figure 28.4.4-3, then there is no modality worklist entry to associate the originally acquired images with. The images would thus require manual correction on the Acquisition Modality. The corrected images are assigned new SOP Instance UIDs so that they can be distinguished from the originally acquired images which have already been exported. In order to communicate the corrected images to other systems, the Acquisition Modality, as a Change Requester, creates a new MPPS. It then stores the new set of corrected images with manually corrected headers to the Image Manager [RAD-74], completes the MPPS and sends it [RAD-7].

5295 Instead of being handled as an unscheduled case, a new procedure could be scheduled on the DSS/OF. In this case the technical aspects would follow the normal Scheduled Workflow sequencing with the exception that, rather than acquiring new images, the originally acquired images would be updated to correspond to the new scheduled procedure obtained from the Modality Worklist.

5300 Note: IHE Scheduled Workflow Profile defines an PPS Exception Management Option (RAD TF-1:3.3.4 and RAD TF-2:4.7.4.1.3.1) which specifies how to correct the incorrectly selected worklist entry after the Modality Performed Procedure Step In Progress transaction has been issued but before the Modality Performed Procedure Step Completed transaction is issued. Notice that there is no external component involved in this situation since the acquired images usually have not been shared prior to MPPS complete or discontinued.

Variants: Instead of an Acquisition Modality being the Change Requester, an Image Manager is the Change Requester. In this case, the Image Manager uses the received procedure information from Procedure Scheduled [RAD-4] and Procedure Updated [RAD-13] to choose the correct

5305 modality worklist, updates the images and creates a new set as described above. The Image Manager does not have to create an MPPS referencing the Rejection Note or an MPPS referencing the corrected images.

5310 **Variants:** Instead of selecting an incorrect modality worklist entry, the Technologist forgets to complete the previous worklist entry before starting the new acquisition. The acquired images are incorrectly appended to an existing study of a different patient for a different procedure. As a result, the resulting study becomes partially incorrect. Only the incorrect images and/or presentation states are required to be corrected.

28.5 Imaging Object Change Management Security Considerations

The section describes the policies for reducing risks after correction or rejection at the Change Requester.

5315 Images that are marked as "rejected" for quality reasons (see Section 28.4.2) may or may not contain clinically relevant information. They may be useful in certain situations. Sites may decide to provide them regularly as part of a Study or may hide them at the Archive or at Workstations. IHE supports such policies by defining configurable behavior at the Image Manager/ Image Archive for storage and at the Image Display for presentation.

5320 Incorrectly labeled images (see Section 28.4.3), e.g., containing a wrong patient orientation or laterality, may mislead image interpretation and thus may be harmful to a patient. For patient safety reasons, they are marked in order to not be used later; an Archive hides such images and does not provide them in IHE-defined query and retrieve transactions.

5325 IHE defines a Key Object Selection document with a special title code as a specific trigger to the Image Manager for hiding incorrect instances (different from general Key Image Note use, RAD TF-1: 8).

5330 Note that a central correction mechanism at the Image Manager/ Image Archive decreases the risk for harmful or misleading use of rejected or incorrect images, such images are not included in regular query results or retrieve transactions, and their presentation does not depend on local configuration of individual workstations.

Rarely, race conditions may result from information in archived images that is not yet corrected, e.g., due to latencies from asynchronous messaging. In this case, Image Displays may receive and present inconsistent, incomplete or wrong information.

5335 The correction and rejection mechanisms defined for IHE Imaging Object Change Management Integration Profile will only correctly work in a system environment where each system implements the corresponding Actors from this integration profile. In addition, the Image Manager/ Archive and Displays need to be configured in a way that meets the department or enterprise policies.

5340 The correction and rejection mechanisms are capable of deleting or changing evidence of a performed procedure. That means a malicious user or system can use this mechanism to hide a mistake. Therefore, the audit record should include information about who initiates the correction / rejection as well as the reason of the initiation. Traceability is also available using

the Referenced Instance Sequence (see RAD TF-3: 4.74.4.1.2) in the header of the replacement instances.

- 5345 Since any actor can group with the Change Requester, it is important for the Image Manager / Archive to validate the source and authority of the Change Requester before rejecting any referenced instances in the KOS. For example, the Image Manager / Archive can restrict rejection of instances referenced in the received KOS if and only if the KOS is sent from the same DICOM Application Entity as the original instances.

5350 **29 Cross-Community Access for Imaging (XCA-I)**

The Cross-Community Access for Imaging (XCA-I) Integration Profile specifies actors and transactions to query and retrieve patient-relevant medical imaging data being held by other communities.

5355 Within a community, a group of facilities/enterprises shares clinical information via an established mechanism such as XDS-I (in which case the community can be referred to as an XDS Affinity Domain). This profile addresses sharing between such communities.

5360 The XCA-I Profile extends the IT Infrastructure XCA Profile. XCA provides access to Diagnostic reports and Imaging Manifests. XCA-I provides access to the imaging objects referenced in the Manifests. The reader of XCA-I is expected to have read and understood the XCA Profile, including the meaning of terms such as Community, homeCommunityId, etc.

29.1 Actors/ Transactions

Figure 29.1-1 shows the actors defined in the Cross-Community Access for Imaging (XCA-I) Profile and the transactions between them.

5365 The shaded actors are NOT included in this profile but are shown to illustrate the full set of actors that play a role other endpoint of transactions that ARE part of the profile (e.g., the Document Registry Actor is an endpoint for the Registry Stored Query [ITI-18] transaction). As a result, the shaded actors are not listed in Table 29.1-1.

5370

5375

5380

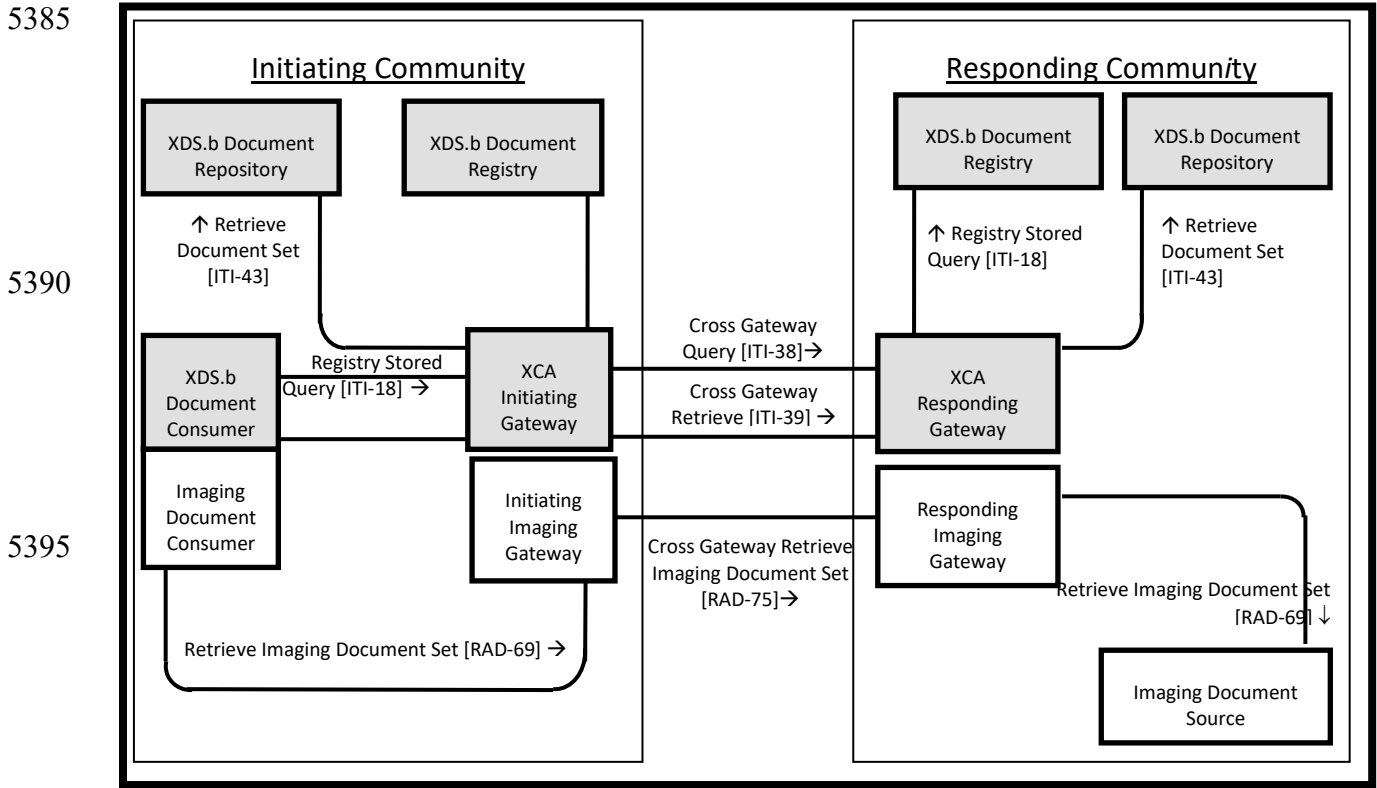

Figure 29.1-1: Cross-Community Access for Imaging Actor Diagram

Table 29.1-1 lists the transactions for each actor directly involved in the XCA-I Profile. To claim support of this Profile, an implementation must perform the required transactions (labeled “R”). Transactions labeled “O” are optional. A complete list of options defined by this integration profile and that implementations may choose to support is listed in Section 29.2.

Table 29.1-1: Cross-Community Access for Imaging Integration Profile - Actors and Transactions

Actors	Transactions	Optionality	TF Reference
Imaging Document Consumer	Retrieve Imaging Document Set [RAD-69]	R	RAD TF-3: 4.69
Imaging Document Source	Retrieve Imaging Document Set [RAD-69]	R	RAD TF-3: 4.69
Initiating Imaging Gateway	Retrieve Imaging Document Set [RAD-69]	R	RAD TF-3: 4.69
	Cross Gateway Retrieve Imaging Document Set [RAD-75]	R	RAD TF-3: 4.75
Responding Imaging Gateway	Cross Gateway Retrieve Imaging Document Set [RAD-75]	R	RAD TF-3: 4.75
	Retrieve Imaging Document Set [RAD-69]	R	RAD TF-3: 4.69

29.1.1 Actor Requirements

5410 The Responding Imaging Gateway shall support the use of Asynchronous Web Services Methods (see ITI TF-2x: Appendix V) for the [RAD-75] transaction.

The Initiating Imaging Gateway is required to support Asynchronous Web Services Exchange for the [RAD-69] transaction.

29.2 XCA-I Profile Options

5415 Options that may be selected for this integration profile are listed in the Table 29.2-1 along with the Actors to which they apply. Dependencies between options when applicable are specified in notes.

Table 29.2-1: Cross-Community Access for Imaging - Actors and Options

Actor	Options	TF Reference
Imaging Document Consumer	Asynchronous Web Services	RAD TF-3: 4.69.4.3
Initiating Imaging Gateway	Asynchronous Web Services	RAD TF-3: 4.75.4.2 RAD TF-3: 4.69.4.3
Responding Imaging Gateway	<i>No options defined</i>	-
Imaging Document Source	Asynchronous Web Services	RAD TF-3: 4.69.4.3

29.3 XCA-I Process Flow

5420 The XCA-I Profile addresses sharing image data sets between communities.

29.3.1 Use Case – Image set sharing between communities

Assume a geographically dispersed region, such as Southeast Wisconsin, with several healthcare communities (or XDS Affinity Domains). One community provides image sharing services for Greater Milwaukee region and one for Kenosha region.

- 5425
- In each community, a Health Information Exchange Service Provider (HIE-SP) provides:
 - an XDS Infrastructure (an XDS Registry and an XDS Repository) for sharing reports and image manifests.
 - an Affinity Domain with a common patient identifier and common coded terminology for managing the sharing of images.
- 5430
- In each community, Diagnostic Imaging Service Providers provide access to locally stored images through transactions defined by the XDS-I.b Integration Profile.
 - Two communities agree to share patient records for urgent care using transactions defined in XCA-I.

5435 A patient X, who receives her primary care in Kenosha, frequently travels to the Greater Milwaukee region for business. While visiting Milwaukee, patient X is admitted to the Milwaukee University Hospital (MUH) for urgent care. The attending physician places an imaging procedure order.

5440 The local PACS, acting as an XDS-I.b Imaging Document Consumer, performs an automated query for relevant priors within the Greater Milwaukee region and to the Kenosha region through an XDS.b Stored Query transaction to the local HIE-SP's Initiating Gateway.

The Initiating Gateway in Greater Milwaukee queries both the local Document Registry and the Responding Gateway for Kenosha. Relevant priors are located in Kenosha and in the South Milwaukee Diagnostic Imaging Center. The South Milwaukee Diagnostic Imaging Center shares images using XDS-I.b as part of the Greater Milwaukee region.

5445 The MUH PACS, acting as an XDS-I.b Imaging Document Consumer, directly accesses images from the South Milwaukee Diagnostic Imaging Center via their XDS I.b Imaging Document Source.

5450 Images from the Kenosha region are retrieved through the Greater Milwaukee HIE-SP's XCA-I Initiating Imaging Gateway, retrieving the images from the Kenosha HIE-SP's XCA-I Responding Imaging Gateway. The Kenosha HIE-SP XCA-I Responding Imaging Gateway, in turn, retrieves the images from Imaging Document Source imaging repositories in the Kenosha region.

29.3.2 Detailed Interactions

5455 The following diagram presents a high level view of the interactions between actors when both initiating and responding communities are XDS-I.b Affinity Domains. Details on each interaction follow the diagram.

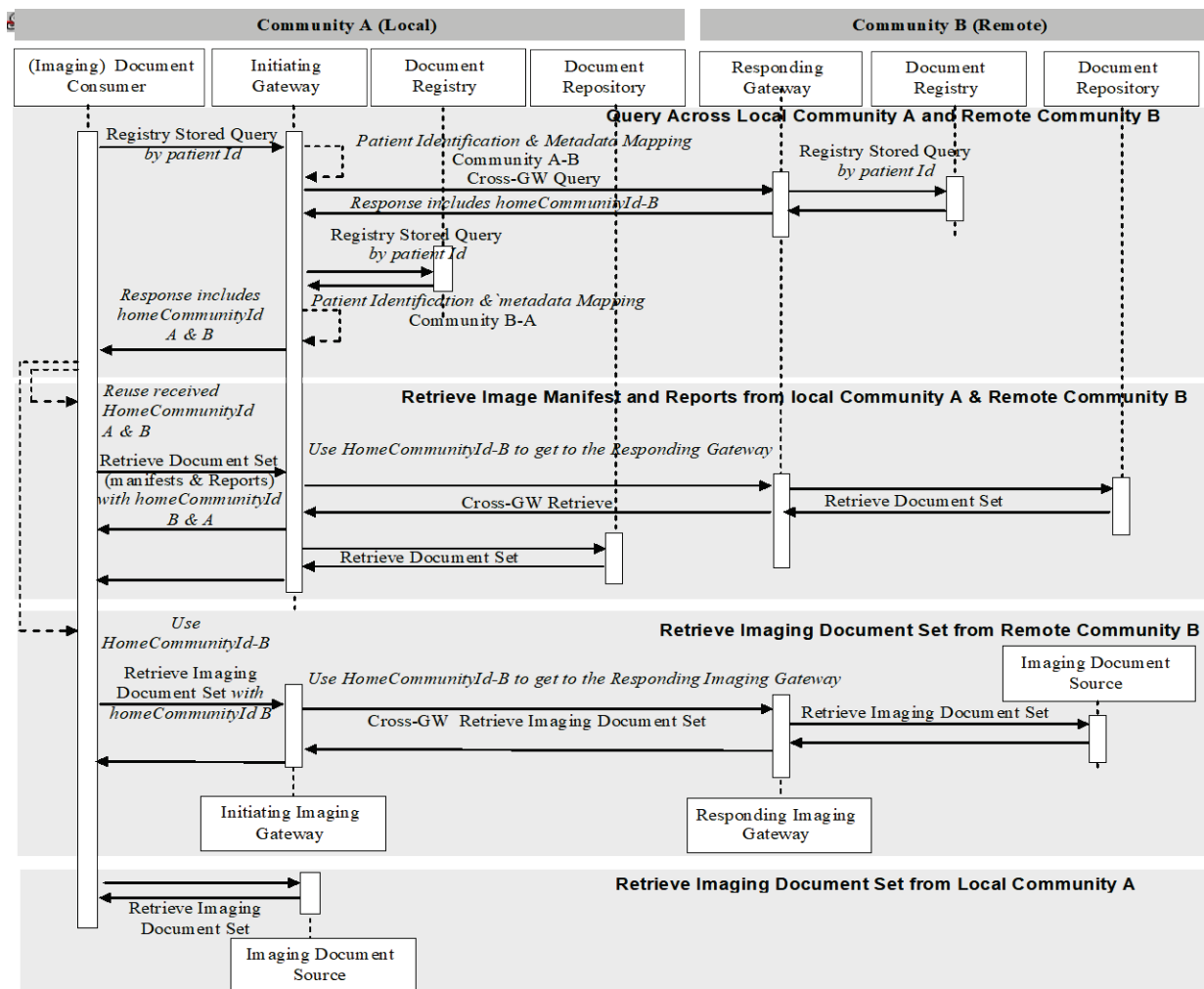

Figure 29.3.2-1: XCA-I Detailed Interactions

- 5460 **Query across Local Community A and Remote Community: Document Consumer** *initiates a Registry Stored Query request by patient id* – the Document Consumer initiates the initial transaction by formatting a Registry Stored Query request by patient identifier. The consumer uses PDQ, PIX or some other means to identify the Local Affinity Domain patient id, formats that information plus any other query parameters into a Registry Stored Query request and sends this request to an Initiating Gateway.
- 5465 **Initiating Gateway** *processes Registry Stored Query by patient id request* – The Initiating Gateway receives a Registry Stored Query by patient id and must determine
- Which Responding Gateways this request should be sent to
 - What patient id to use in the Cross Gateway Queries. Detailed specification of these steps is not in the intended scope of this profile. Combination of this profile with other existing profiles (e.g., XCPD, PIX/PDQ), future profiles or configuration mechanisms is possible.
- 5470

Please refer to ITI TF-2x: E.7 *XCA and Patient Identification Management* for possible use of existing ITI PIX and PDQ Profiles.

5475 For each Responding Gateway identified, the Initiating Gateway initiates a Cross Gateway Query transaction. The Initiating Gateway also initiates a Registry Stored Query to the local Document Registry.

5480 **Responding Gateway processes Cross Gateway Query by patient id** – The Responding Gateway processes the Cross Gateway Query by initiating a Registry Stored Query to the local Document Registry. The Responding Gateway updates the response from the Document Registry to ensure that the homeCommunityId is specified on every applicable element. This updated response is sent as the response to the Cross Gateway Query.

5485 **Initiating Gateway processes Cross Gateway Query by patient id responses** – The Initiating Gateway collects the responses from all Responding Gateways it contacted. For each response it verifies that the homeCommunityId is present in each appropriate element. Once all responses are received the Initiating Gateway consolidates all updated response data into one response to the Document Consumer. The Initiating Gateway returns to the Document Consumer the same homeCommunityId attribute values that it received from Responding Gateway(s).

5490 **Document Consumer receives Registry Stored Query by patient id response** – The Document Consumer receives the results of the query from the Initiating Gateway and must account for three unique aspects of the response; namely that a) the homeCommunityId attribute will be specified, b) the Document Consumer may not be able to map the repositoryUniqueId value directly to a Document Repository located in a remote community, and c) the Document Consumer may not be able to understand the terminology used in the response. For example, if the initiating and responding community have common Requested Procedure vocabularies, then the Initiating Gateway will respond to the Document Consumer's request using the common coding/vocabulary scheme. The Document Consumer retains the values of the homeCommunityId attribute for future interaction with the Initiating Gateway.

5495

Retrieve Image Manifest and Reports from local Community A & Remote Community B:

5500 **Document Consumer initiates a Retrieve Document Set** – If the Document Consumer issued a Registry Stored Query, the response to the Registry Stored Query by patient id includes a) the document uniqueId b) the repositoryUniqueId, and c) the homeCommunityId attribute. The Document Consumer shall specify these three parameters in its Retrieve Document Set transaction to the Initiating Gateway.

5505 **Initiating Gateway processes Retrieve Document Set** – The Initiating Gateway determines which Responding Gateway(s) to contact by using the homeCommunityId to obtain the Web Services endpoint of the Responding Gateway(s). If the homeCommunityId represents the local community, the Initiating Gateway will initiate a Retrieve Document Set to the indicated local Document Repository. The Retrieve Document Set may contain more than one unique homeCommunityId so the Initiating Gateway may have to initiate requests to more than one Responding Gateway, and consolidate the results. The Initiating Gateway specifies the homeCommunityId in the Cross Gateway Retrieve transaction. The homeCommunityId identifies the community associated with the Responding Gateway.

5510

Responding Gateway processes Cross Gateway Retrieve– The Responding Gateway within an XDS Affinity Domain processes the Cross Gateway Retrieve initiating a Retrieve Document Set transaction to the Document Repository identified by the repositoryUniqueId within the request. 5515 If the Cross Gateway Retrieve requests multiple documents with different repositoryUniqueIds, the Responding Gateway will contact multiple Document Repositories and consolidate the responses.

Retrieve Image Set from Remote Community B

Imaging Document Consumer initiates a Retrieve Imaging Document Set. The request includes 5520 a) the repositoryUniqueId identifying the Imaging Document Source, b) the documentUniqueIds identifying the imaging documents (DICOM SOP Instance UIDs) within the Imaging Document Source c) list of one or more DICOM transfer syntax UIDs, d) Study Instance UID, e) Series Instance UID f) the homeCommunityId attribute. The Imaging Document Consumer specifies these parameters in its Retrieve Imaging Document Set transaction to the Initiating Imaging 5525 Gateway.

Initiating Imaging Gateway processes Retrieve Imaging Document Set – The Initiating Imaging Gateway determines which Responding Imaging Gateways to contact by using the homeCommunityId to obtain the Web Services endpoint of the Responding Imaging Gateway. 5530 The Retrieve Imaging Document Set may contain more than one unique homeCommunityId so the Initiating Imaging Gateway may have to initiate requests to more than one Responding Imaging Gateway, and consolidate the results. The Initiating Imaging Gateway specifies the homeCommunityId in the Cross Gateway Retrieve Imaging Document Set transaction. The homeCommunityId identifies the community associated with the Responding Imaging Gateway.

Responding Imaging Gateway processes Cross Gateway Retrieve Imaging Document Set – The 5535 Responding Imaging Gateway within an XDS Affinity Domain processes the Cross Gateway Retrieve Imaging Document Set request by initiating a Retrieve Imaging Document Set transaction to the Imaging Document Source identified by the repositoryUniqueId within the request. If the Cross Gateway Retrieve Imaging Document Set requests multiple documents with different repositoryUniqueIds, the Responding Imaging Gateway will contact multiple Imaging 5540 Document Sources and consolidate the responses.

Retrieve Image Set from Local Community A

Imaging Document Consumer initiates a Retrieve Imaging Document Set – The request 5545 includes a) the repositoryUniqueId identifying the Imaging Document Source, b) the documentUniqueIds identifying the documents (DICOM SOP Instance UIDs) within the Imaging Document Source c) list of one or more DICOM transfer syntax UIDs, d) Study Instance UID, e) Series Instance UID f) the homeCommunityId attribute. Because the homeCommunityId represents the local community, the Imaging Document Consumer will initiate a Retrieve Imaging Document Set to the local Imaging Document Source.

29.3.3 Actor Grouping Considerations

5550 XCA-I presumes the community uses the XDS-I.b and XDS.b integration profiles for enabling Imaging Document Set behavior. XCA-I defines no required grouping with any actor. The

5555 implementer may consider grouping actors as needed. For example, an Image Document Source may choose to group with an IRWF Importer for importing images. The XCA-I Profile does not explicitly group the XCA-I Initiating Imaging Gateway and XCA Initiating Gateway pair and the XCA-I Responding Imaging Gateway and XCA Responding Gateway pair.

The XCA-I Profile requires that the Initiating and Responding Imaging Gateways that are used in conjunction with the XCA Initiating and Responding Gateways and will be part of XDS communities that support XDS.b.

29.4 XCA-I Security Considerations

5560 29.4.1 XCA Risk Assessment

The risk analysis for XCA enumerates assets, threats, and mitigations. The complete risk data is stored and maintained in a central location. The complete risk data is stored and available from IHE⁴.

5565 The risks associated with the data content and protocols of [RAD-69] and [RAD-75] are a subset of those identified for the transactions in the ITI XCA Profile.

29.4.2 Requirements/Recommendations

The following mitigations shall be implemented by all XCA-I actors. These mitigations moderate all high impact risks.

5570 **M1:** All actors in XCA-I shall be grouped with an ATNA Secure Node or Secure Application Actor and a CT Time Client Actor.

M2: An Imaging Document Source shall include a SHA1 hash of the image document content in the Document metadata of the [RAD-68] response. The Imaging Document Consumer shall have the ability to verify the SHA1 hash of the image document with the SHA1 hash in the metadata.

5575 **M3:** Imaging Document Consumer implementations shall handle overloading through excessive volume of response data by discontinuing the read on the socket and closing it. The Initiating and Responding Imaging Gateways shall respond to disconnection by discontinuing processing of responses.

5580 **M6:** The Responding Imaging Gateway shall return either zero documents with no further information or XDSUnknownPatientId in response to queries of unknown patient identifiers, depending on local policy. This applies to patient identifiers that are properly formatted or improperly formatted. By not using an error code indicating that the identifier is ill formatted, you are able to reduce the ability of applications to fish for data.

⁴ The risk analysis data may be found at: ftp://ftp.ihe.net/IT_Infrastructure/iheitiyr5-2007-2008/Technical_Cmte/Profile_Work/XC/XCARiskAnalysis.xls

5585 *The following mitigations address the risk of a document being maliciously changed. This mitigation is optional.*

M5: Documents may be digitally signed using the ITI Digital Signature (DSG) Profile

The following mitigations are transferred to the vendors, XDS Affinity Domains, and enterprises.

5590 **T1:** Backup systems for registry metadata, repository documents, and gateway configuration are recommended.

T2: All implementations are recommended to ensure that all received data is propagated appropriately (i.e., without corruption and complete results) or an error is presented.

5595 **T3:** Network protection services are recommended to be sufficient to guard against denial of service attacks on all service interfaces.

T4: A process that reviews audit records and acts on inappropriate actions is recommended.

T5: It is recommended that service interfaces be implemented with a good design to guard against corruption and denial of service attacks

29.4.3 Policy Choices

5600 Security and privacy policy choices will not be addressed by this profile. Each community may have different security and privacy policies. The profile has been designed with this fact in mind and an understanding of enough variety of policies so that any reasonable policy can be implemented without violating the profile.

30 Post Acquisition Workflow (PAWF)

5605 This section intentionally, temporarily left blank.

31 Cross-Enterprise Document Reliable Interchange of Images (XDR-I)

This section intentionally, temporarily left blank.

32 Stereotactic Mammography Image (SMI)

5610 This section intentionally, temporarily left blank.

33 Management of Radiology Report Templates (MRRT)

This section intentionally, temporarily left blank.

34 Scheduled Workflow.b (SWF.b)

This section intentionally, temporarily left blank.

5615 **35 Invoke Image Display (IID)**

This section intentionally, temporarily left blank.

36 Intentionally left blank

5620 This section was previously reserved for the Mobile access to Health Documents for Imaging (MHD-I) Profile. That profile was deprecated in 2017 and replaced with the Web-based Image Access (WIA) Profile.

37 Digital Breast Tomosynthesis (DBT)

5625 The Digital Breast Tomosynthesis (DBT) Profile specifies the creation, exchange and use of DBT images. It defines basic display capabilities that Image Displays are expected to provide, especially simultaneous review of DBT and conventional 2D mammography images (FFDM).

The Digital Breast Tomosynthesis Profile is designed to provide faithful storage and retrieval of DBT images. Furthermore, sufficient display functionality to allow adequate review of current and prior studies consisting of DBT and/or conventional 2D mammography images is defined. The support for CAD is out of the scope for this profile.

5630 37.1 DBT Actors, Transactions, and Content Modules

This section defines the actors, transactions, and/or content modules in this profile.

5635 Figure 37.1-1 shows the actors directly involved in the Digital Breast Tomosynthesis Profile and the relevant transactions between them. If needed for context, other actors that may be indirectly involved due to their participation in other related profiles are shown in dotted lines. Actors which have a mandatory grouping are shown in conjoined boxes.

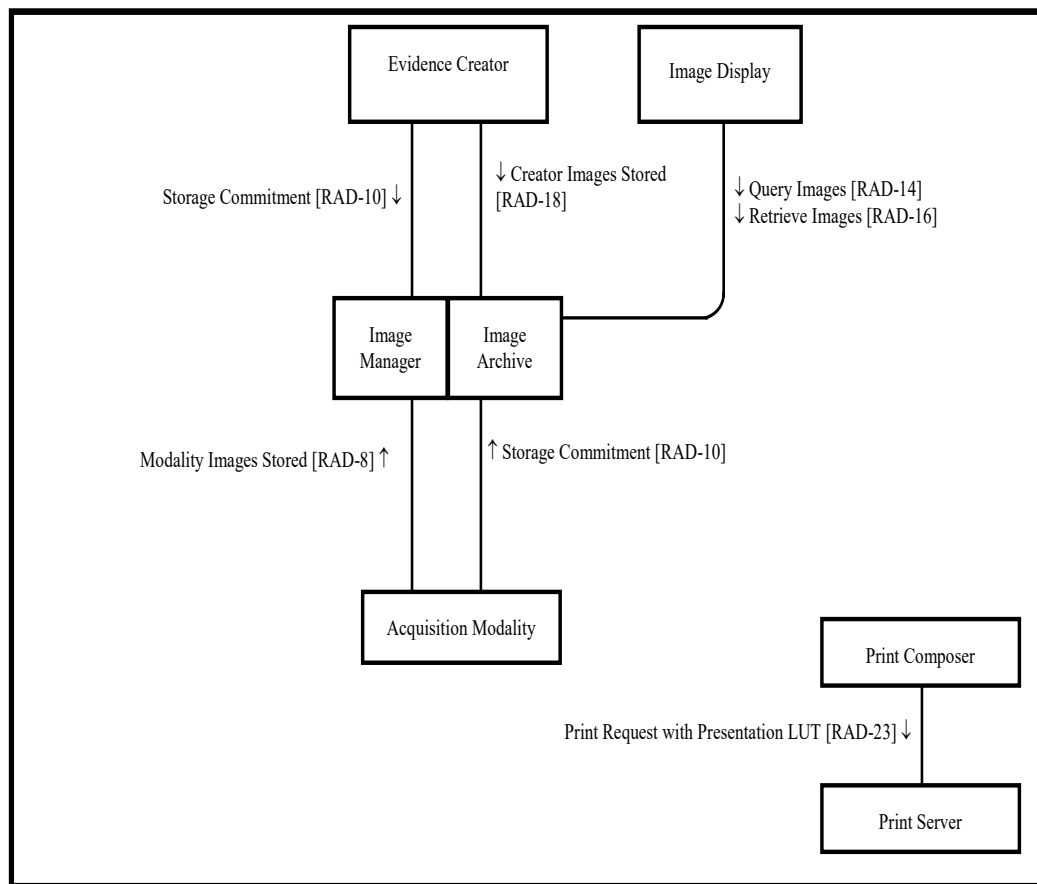

Figure 37.1-1: DBT Actor Diagram

5640 Table 37.1-1 lists the transactions for each actor directly involved in the Digital Breast Tomosynthesis Profile. To claim compliance with this profile, an actor shall support all required transactions (labeled “R”) and may support the optional transactions (labeled “O”).

Table 37.1-1: DBT Profile - Actors and Transactions

Actors	Transactions	Optionality	TF Reference
Acquisition Modality	Modality Images Stored [RAD-8]	R	RAD TF-2: 4.8
	Storage Commitment [RAD-10]	R	RAD TF-2: 4.10
Evidence Creator	Creator Images Stored [RAD-18]	R	RAD TF-2: 4.18
	Storage Commitment [RAD-10]	R	RAD TF-2: 4.10
Image Manager/Archive	Modality Images Stored [RAD-8]	R	RAD TF-2: 4.8
	Storage Commitment [RAD-10]	R	RAD TF-2: 4.10
	Query Images [RAD-14]	R	RAD TF-2: 4.14
	Retrieve Images [RAD-16]	R	RAD TF-2: 4.16
	Creator Images Stored [RAD-18]	R	RAD TF-2: 4.18
Image Display	Query Images [RAD-14]	R	RAD TF-2: 4.14
	Retrieve Images [RAD-16]	R	RAD TF-2: 4.16
Print Composer	Print Request with Presentation LUT [RAD-23]	R	RAD TF-2: 4.23
Print Server	Print Request with Presentation LUT [RAD-23]	R	RAD TF-2: 4.23

37.1.1 Actor Descriptions and Actor Profile Requirements

5645 Most requirements are documented in Transactions (Volume 2 and 3). This section documents any additional requirements on this profile’s actors.

37.1.1.1 Acquisition Modality

The Acquisition Modality Actor acquires breast projection X-Ray images and generates tomosynthesis images.

5650 The Acquisition Modality can optionally acquire conventional 2D mammography images or generate a 2D image mathematically from tomosynthesis data. Creation and storage of conventional 2D mammography images is facilitated by grouping the Acquisition Modality in the DBT Profile with an Acquisition Modality from the Mammography Image Profile (see Section 19).

5655 In order to generate and store additional derived tomosynthesis reconstructions (e.g., slabs), the Acquisition Modality can be grouped with an Evidence Creator Actor.

37.1.1.2 Image Manager/Archive

The Image Manager/Archive Actor receives breast tomosynthesis images, conventional 2D mammography images, 2D images generated mathematically from tomosynthesis data from the

5660 Acquisition Modality or an Evidence Creator Actor, responds to query requests, and stores requested image data to an Image Display.

37.1.1.3 Image Display

5665 The Image Display Actor retrieves breast tomosynthesis images as well as 2D images generated mathematically from tomosynthesis data and/or conventional 2D mammography images from the current and prior exams and displays them. The Image Display can be grouped with an Evidence Creator Actor in order generate derived tomosynthesis reconstructions (e.g., slabs).

37.1.1.4 Evidence Creator

5670 Evidence Creator Actors generate derived tomosynthesis reconstructions (e.g., slabs). The Evidence Creator can be grouped with the Acquisition Modality or the Image Display in order to access the images. If the Evidence Creator is a stand-alone system, the workflow to get access to the images is out of scope for this profile. The Evidence Creator uses the Creator Images Stored [RAD-18] transaction to store these reconstructions (see RAD TF-2: 4.18.4.1.2.5).

37.1.1.5 Print Composer

5675 Print Composer Actors assemble film sheets of the selected key images and send print requests to a Print Server. A Print Composer can be grouped with an Image Display in order to get access to the key images. If the Print Composer is a stand-alone system, the workflow to get access to the key images is out of scope for this profile.

37.1.1.6 Print Server

The Print Server Actor processes the print requests from a Print Composer Actor.

37.2 DBT Actor Options

5680

Table 37.2-1: DBT - Actors and Options

Actor	Option Name	TF Reference
Acquisition Modality	Partial View	RAD TF-1: 37.2.2
	Media Creation	RAD TF-1: 37.2.6
Evidence Creator	<i>No options defined</i>	--
Image Manager/Archive	Key Images	RAD TF-1: 37.2.1
	User Annotation	RAD TF-1: 37.2.5
Image Display	Key Images	RAD TF-1: 37.2.1
	Partial View	RAD TF-1: 37.2.2
	User Annotation	RAD TF-1: 37.2.5
	Media Creation	RAD TF-1: 37.2.6
Print Composer	<i>No options defined</i>	--
Print Server	<i>No options defined</i>	--

37.2.1 Key Images Option

The Key Images Option enables users to mark key images or frames of a breast tomosynthesis image by attaching a Key Image Note and provide them for display. The functionality is defined in the Key Image Note Profile (RAD TF-1:8); therefore, this functionality is achieved by grouping with relevant actors from the Key Image Note Profile:

5685

- Image Displays that support creation of Key Image Notes shall be grouped with an Evidence Creator in the Key Image Note Profile and shall be able to create and store Key Image Notes for one or more of the SOP classes in RAD TF-2: Table 4.16.4.1.3.7-1.
- Image Displays that support rendering of Key Image Notes shall be grouped with an Image Display Actor in the Key Image Note Profile and shall be able to query, retrieve and render Key Image Notes for one or more of the SOP classes in RAD TF-2: Table 4.16.4.1.3.7-1.
- Image Manager/Archives that support storage and retrieval of Key Image Notes shall be grouped with an Image Manager/Archive Actor in the Key Image Note Profile to enable storage/retrieval of the Key Object Selection Document.

5690

5695

37.2.2 Partial View Option

The Partial View Option addresses the creation and display of mosaic images.

It defines additional attributes which the Acquisition Modality includes in the image headers in order to indicate whether an image is part of a mosaic and which part of the set the image represents as defined in RAD TF-2: 4.8.4.1.2.7.1 Partial View Option.

5700

Furthermore, it defines how Image Display Actors make use of this information to annotate the images in the viewport as defined in RAD TF-2: 4.16.4.2.2.1.3.7 Partial View Option.

37.2.3 For Presentation Breast Projection X-Ray Images Option

This option remains in Trial Implementation. Please refer to the DBT Extensions Trial Implementation Supplement for details.

5705

37.2.4 For Processing Breast Projection X-Ray Images Option

This option remains in Trial Implementation. Please refer to the DBT Extensions Trial Implementation Supplement for details.

37.2.5 User Annotation Option

The User Annotation Option allows users to perform annotation on key images or frames of a breast tomosynthesis image, store it as a Grayscale Softcopy Presentation State, and provide it for display. The functionality is defined in the Consistent Presentation of Images Profile (RAD TF-1:5); therefore, this functionality is achieved by grouping with relevant actors from the Consistent Presentation of Images Profile:

5710

- 5715 • Image Displays that support creation of Grayscale Softcopy Presentation State objects shall be grouped with an Evidence Creator in the Consistent Presentation of Images Profile and shall be able to create and store GSPS objects for one or more of the SOP Classes in RAD TF-2: Table 4.16.4.1.3.7-1.
- 5720 • Image Displays that support rendering of Grayscale Softcopy Presentation State objects shall be grouped with an Image Display Actor in the Consistent Presentation of Images Profile and shall be able to query, retrieve and render GSPS objects for one or more of the SOP Classes in RAD TF-2: Table 4.16.4.1.3.7-1.
- 5725 • Image Manager/Archives that support storage and retrieval of Grayscale Softcopy Presentation State objects shall be grouped with an Image Manager/Archive Actor in the Consistent Presentation of Images Profile to enable storage/retrieval of the Grayscale Softcopy Presentation State objects.

37.2.6 Media Creation Option

5730 The Media Creation Option allows users to export breast tomosynthesis studies to external media. The functionality is defined in the Portable Data for Imaging Profile (see Section 15); therefore, this functionality is achieved by grouping with relevant actors from the Portable Data for Imaging Profile:

- 5735 • Acquisition Modalities or Image Displays that support creation of external media shall be grouped with a Portable Media Creator Actor in the Portable Data for Imaging Profile.
- 5735 • The Portable Media Creator shall be capable of encoding on the media all of the SOP Classes that are required to be supported by the Digital Breast Tomosynthesis Profile (which are defined in the Modality Images Stored and Retrieve Images transactions).
- 5740 • If the Key Images Option is also supported, the Portable Media Creator shall be capable of encoding on the media instances of the Key Object Selection Document Storage SOP Class.
- 5740 • If the User Annotation Option is also supported, the Portable Media Creator shall be capable of encoding on the media instances of the Grayscale Softcopy Presentation State Storage SOP Class.

If a viewer is added to the media in addition to the breast tomosynthesis study, the viewer shall fulfill the Image Display requirements defined in RAD TF-2: 4.16.4.2.2.1.3.11.

5745 37.3 DBT Required Actor Groupings

An actor from this profile (Column 1) shall implement all of the required transactions and/or content modules in this profile in addition to all of the transactions required for the grouped actor (Column 2).

5750 If this is a content profile, and actors from this profile are grouped with actors from a workflow or transport profile, the Content Bindings reference column references any specifications for

mapping data from the content module into data elements from the workflow or transport transactions.

5755 In some cases, required groupings are defined as at least one of an enumerated set of possible actors; this is designated by merging column one into a single cell spanning multiple potential grouped actors. Notes are used to highlight this situation.

Section 37.5 describes some optional groupings that may be of interest for security considerations and Section 37.6 describes some optional groupings in other related profiles.

Table 37.3-1: DBT - Required Actor Groupings

DBT Actor	Actor to be grouped with	Reference	Content Bindings Reference
Image Manager/Archive	Image Manager/Archive in the Mammography Image Profile	RAD TF-1: 19.1	--
Image Display	Image Display in the Mammography Image Profile	RAD TF-1: 19.1	--
Acquisition Modality (see Note 1)	Acquisition Modality in the Mammography Image Profile	RAD TF-1:19.1	--

5760 Note 1: Acquisition Modalities that generate conventional 2D mammography images shall be grouped with an Acquisition Modality in the Mammography Image Profile.

37.4 DBT Overview

The Digital Breast Tomosynthesis (DBT) Profile specifies the creation, exchange and use of DBT images. It defines basic display capabilities that Image Displays are expected to provide, especially simultaneous review of DBT and conventional 2D mammography images (FFDM).

5765 The Digital Breast Tomosynthesis Profile is designed to provide faithful storage and retrieval of DBT images. Furthermore, sufficient display functionality to allow adequate review of current and prior studies consisting of DBT and/or conventional 2D mammography images is defined. The support for CAD is out of the scope for this profile.

37.4.1 Concepts

5770 The Mammography Image Profile provides functionality for faithful storage, retrieval and display of conventional 2D mammography images and associated CAD results. The DBT Profile extends this functionality to support breast tomosynthesis images and images derived from them.

37.4.2 Use Cases

37.4.2.1 Use Case #1: DBT Screening

5775 This use case addresses the basic mammography screening workflow, which includes creation, storage and retrieval of breast tomosynthesis images and optionally conventional 2D mammography images.

37.4.2.1.1 DBT Screening Use Case Description

5780 This use case encompasses a group of scenarios which vary in the number and type of images that are created at the modality and whether a current study only or a current and a prior are reviewed. Each study, current or prior can include one or multiple views of each breast, where one view may contain a set of:

- Tomosynthesis slices
- Tomosynthesis slabs
- 5785 • Conventional 2D mammography images
- Generated 2D images derived from tomosynthesis data

During the review of a study the radiologist can utilize the available display options, such as contrast adjustments, image sizing changes, etc.

The goal for this use case is to support fast reading of the data, which includes:

- 5790 • Instantaneous scrolling through slices
- Instantaneous switching between images (different views, different image types, prior images)
- Instantaneous switching to the next case.

37.4.2.1.2 DBT Screening Process Flow

5795

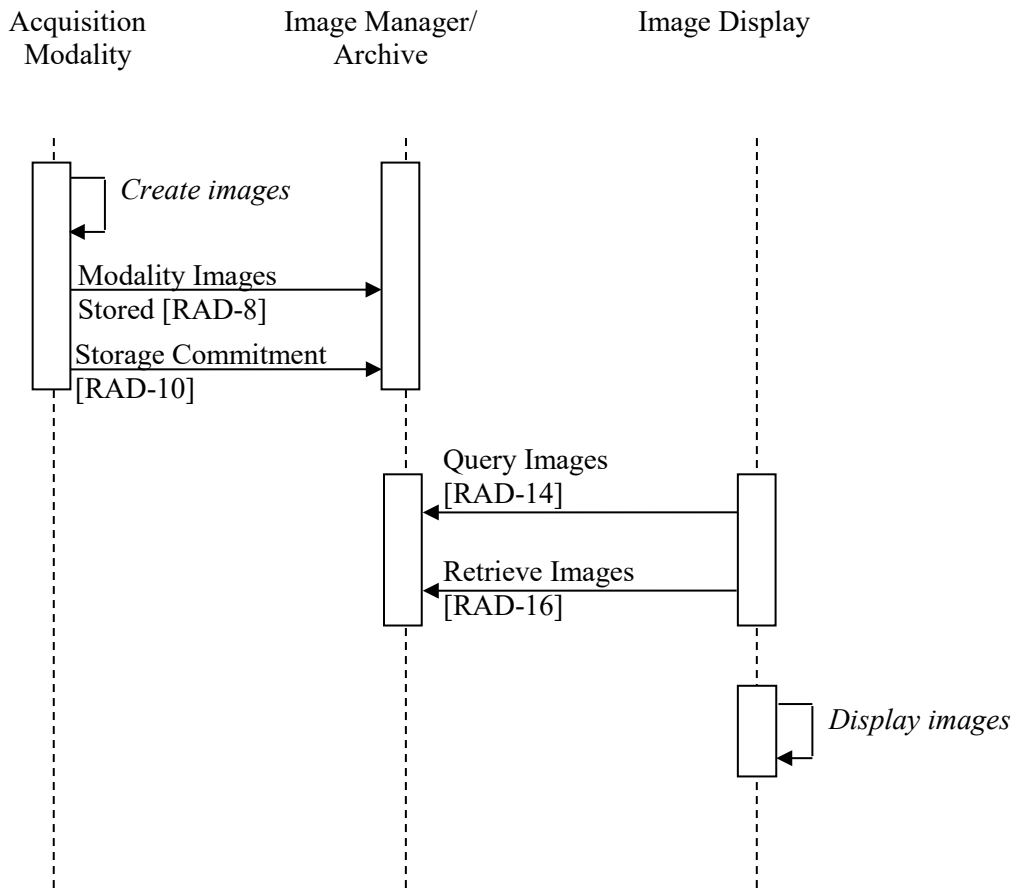

Figure 37.4.2.1.2-1: Process Flow in DBT Screening Use Case

37.4.2.2 Use Case #2: Additional reconstructions

5800 During review of a study, the radiologist requests another DBT image (reconstruction). This may result in a complete volume or a sub-volume of the acquired DBT data.

37.4.2.2.1 Additional Reconstructions Use Case Description

5805 While reviewing the study, the radiologist identifies the need for additional DBT images using different reconstruction parameters. This can be triggered by the lesion type, by the character of the breast tissue (e.g., fatty or dense), any other clinical information (medication, hormone status), or just by the image impression of the first DBT image. Using the functionality of their workstation the radiologist creates the additional DBT image(s) (e.g., using a different slice thickness for reconstruction) either covering the complete volume or a sub-volume. The additional images are stored in the PACS.

37.4.2.2.2 Additional Reconstructions Process Flow

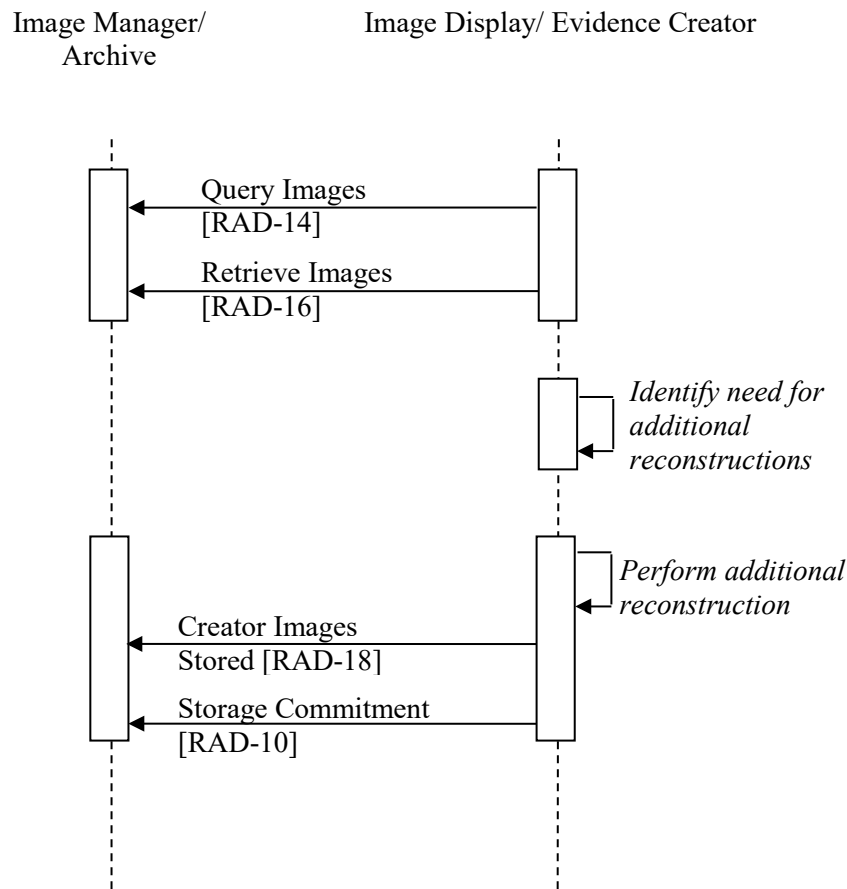

5810

Figure 37.4.2.2.2-1: Process Flow in Additional Reconstructions Use Case

37.4.2.3 Use Case #3: DBT in Diagnostic Mammography

This use case describes acquisition and display of additional DBT images for diagnostic purposes based on the findings in the screening exam.

5815

37.4.2.3.1 DBT in Diagnostic Mammography Use Case Description

Based on findings (e.g., suspected mass, asymmetry) in a conventional 2D mammography or DBT screening study or a palpable finding in the patient, a DBT diagnostic study may be ordered. Exaggerated, rolled, 90-degree (LM, ML) and/or spot compression views are acquired using DBT acquisition or combination 2D/DBT acquisition.

5820

The diagnostic study may contain one or more diagnostic views of a single breast or both breasts, each of which may include a set of:

- Tomosynthesis slices

- Tomosynthesis slabs
 - Conventional 2D mammography images
- 5825
- Generated 2D images derived from tomosynthesis data

During the review of a study the radiologist can utilize the available display options, such as contrast adjustments, image sizing changes, etc.

37.4.2.3.2 DBT in Diagnostic Mammography Process Flow

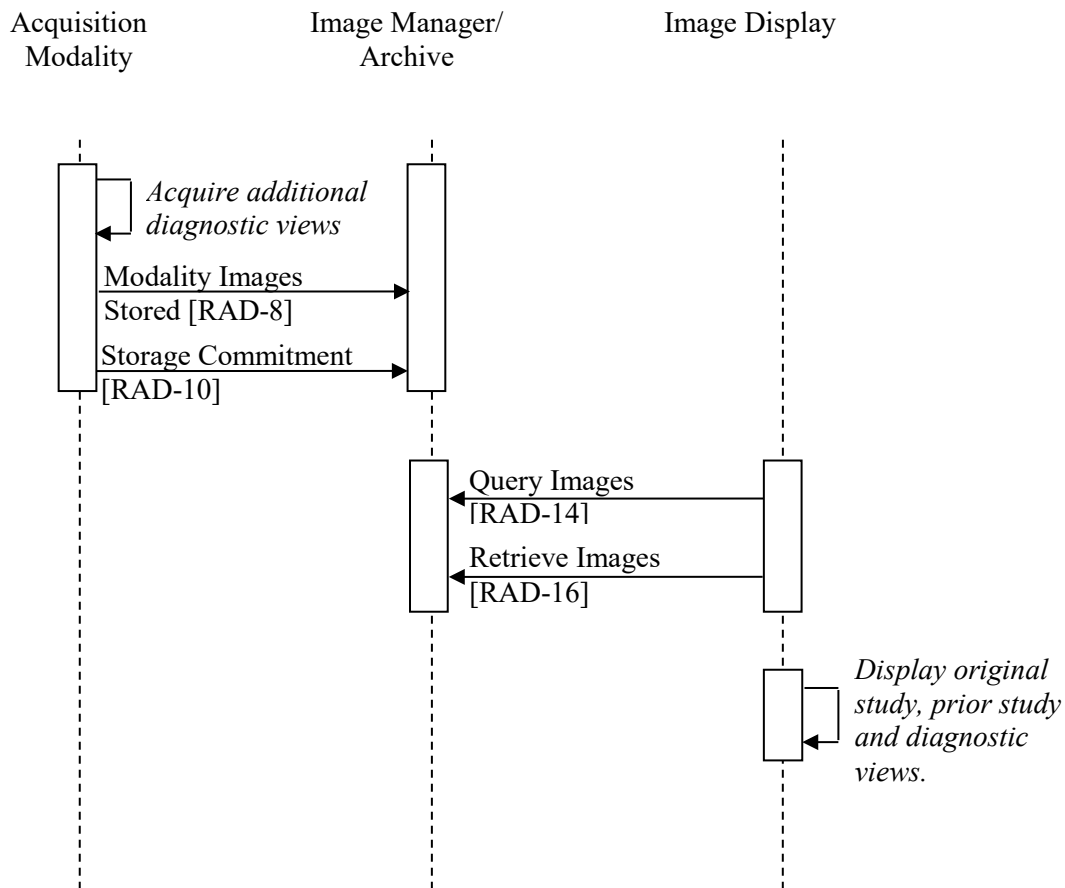

5830 **Figure 37.4.2.3.2-1: Process Flow in DBT for Diagnostic Mammography Use Case**

37.4.2.4 Use Case #4: Key Images in DBT Screening

This use case addresses flagging of key images or frames in the DBT image for further review (e.g., by the referring physician or when asking for a second opinion).

37.4.2.4.1 Key Images in DBT Screening Use Case Description

5835 Due to the size of the DBT image, it is helpful to flag key frames for subsequent reviews (e.g., for a second opinion, for a referring physician or even when reviewed as a prior) in order to find relevant frames faster and not miss key frames while scrolling rapidly.

5840 While reviewing a screening exam, the radiologist identifies a lesion that she/he would like a second opinion on. She/he flags the frame which best represents the finding for a secondary review by a colleague. She/he stores the information about the key frame in the Key Image Note and sends it to the PACS.

5845 The second reader retrieves the images and the Key Image Note on the workstation and opens them. By selecting the Key Image Note, the relevant frame is displayed right away for review. Starting from the flagged images she/he reviews surrounding frames and provides feedback to the other radiologist.

37.4.2.4.2. Key Images in DBT Screening Process Flow

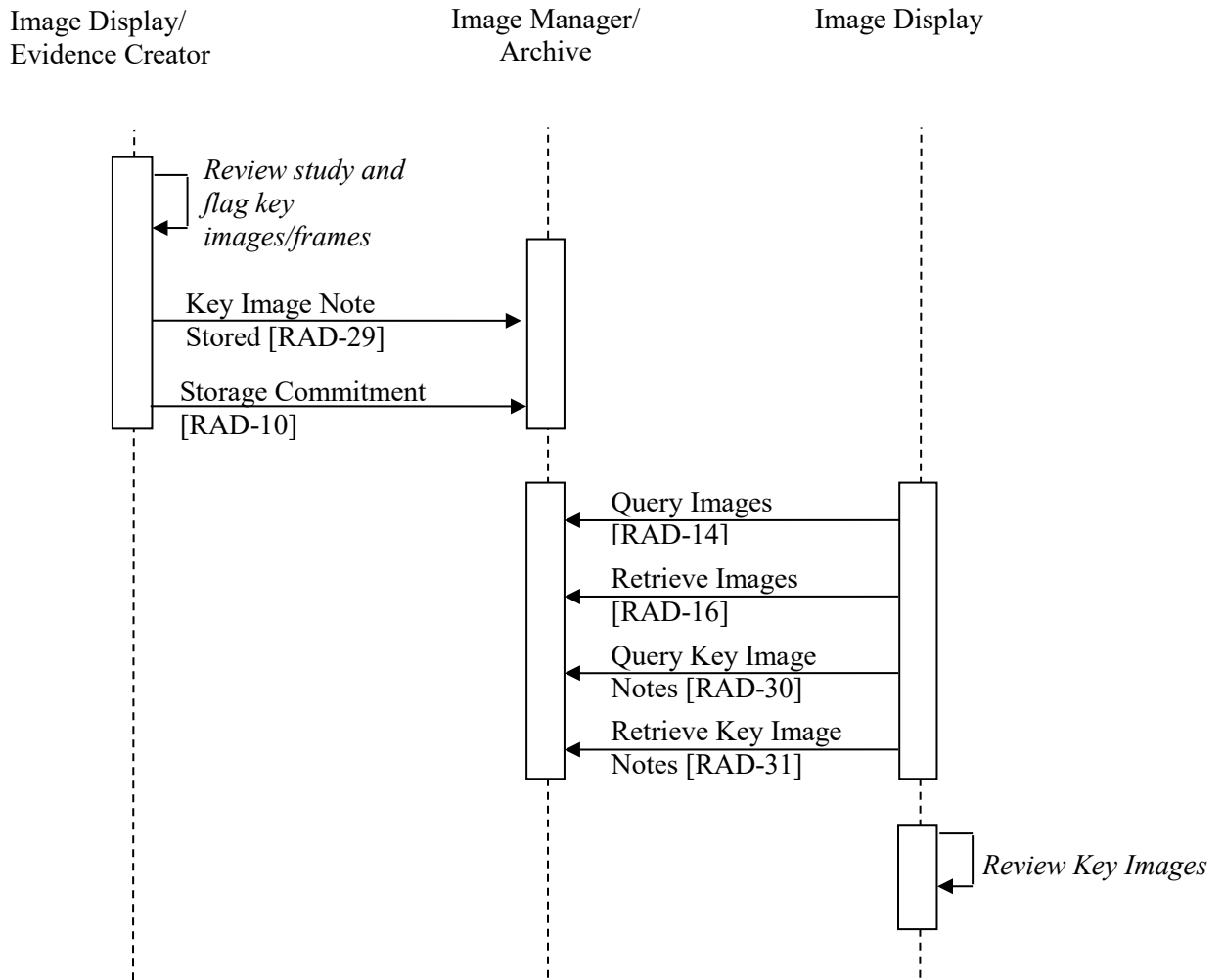

Figure 37.4.2.4.2-1: Process Flow in Key Images in DBT Screening Use Case

37.4.2.5 Use Case #5: User annotation in DBT studies

5850 This use case addresses how to store user annotations on DBT images and make them available for review at a later point in time.

37.4.2.5.1 User annotation in DBT studies Use Case Description

While reviewing a DBT image, the radiologist identifies a lesion that she/he would like a second opinion on. She/he marks the region on the relevant frame for review by a colleague. She/he

5855 stores the user annotation information in a Grayscale Softcopy Presentation State object and sends it to the PACS.

The second reader retrieves the images and the Grayscale Softcopy Presentation State object on the workstation and opens them. By selecting the user annotation, the annotated frame is displayed right away for review showing the marks of the initial reader also applying any zoom and window/level settings stored in the Grayscale Softcopy Presentation State object.

5860

37.4.2.5.2 User annotation in DBT studies Process Flow

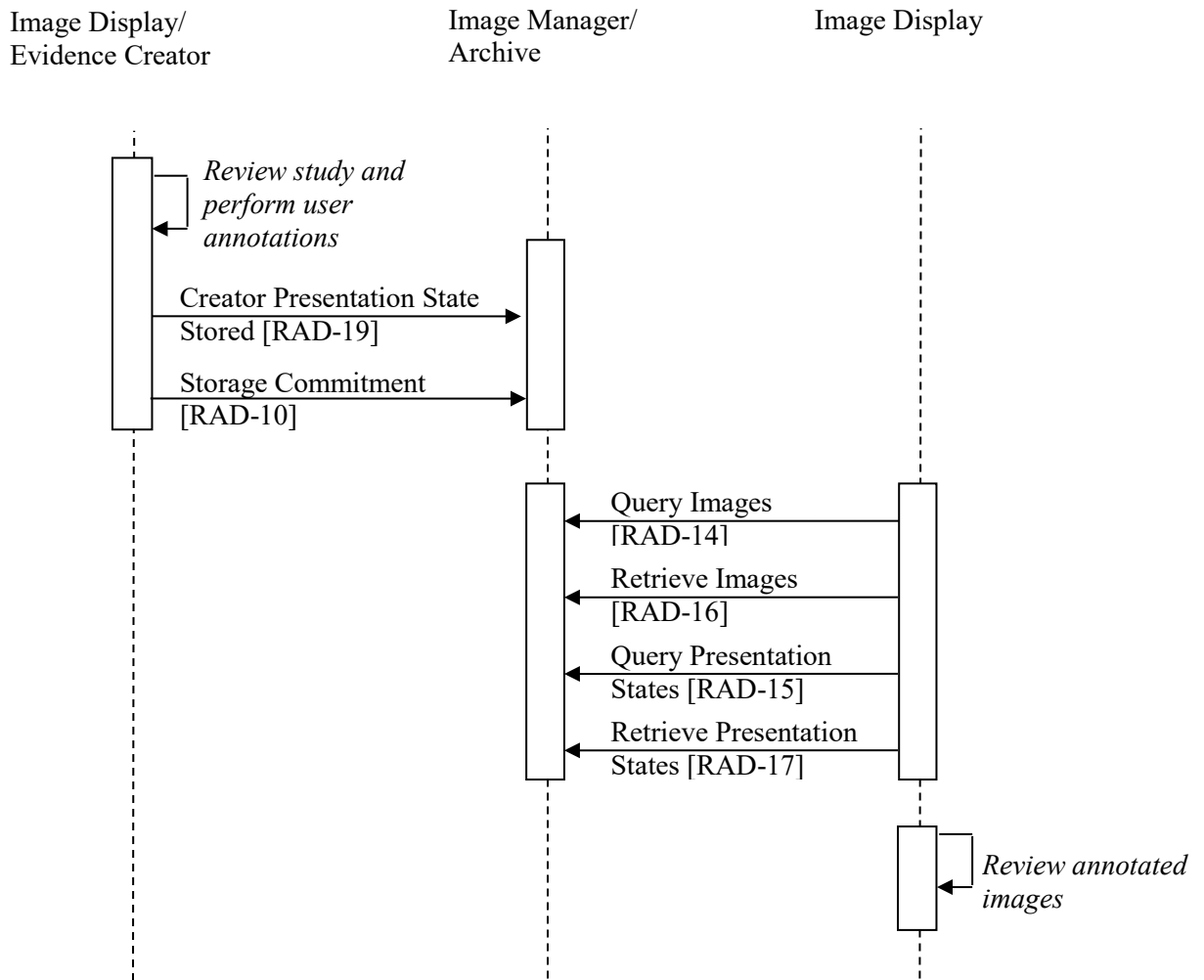

Figure 37.4.2.5.2-1: Process Flow in User Annotation in DBT studies Use Case

37.4.2.6 Use Case #6: Printing of selected DBT Frames

5865 This use case addresses printing of selected frames from a DBT study.

37.4.2.6.1 Printing of selected DBT Frames Use Case Description

During reviewing a DBT study, the clinician selects particular frames (with or without annotation) and wants to format them for printing. Options for printing are either in True Size or in Same Size.

5870 37.4.2.6.2 Printing of selected DBT Frames Process Flow

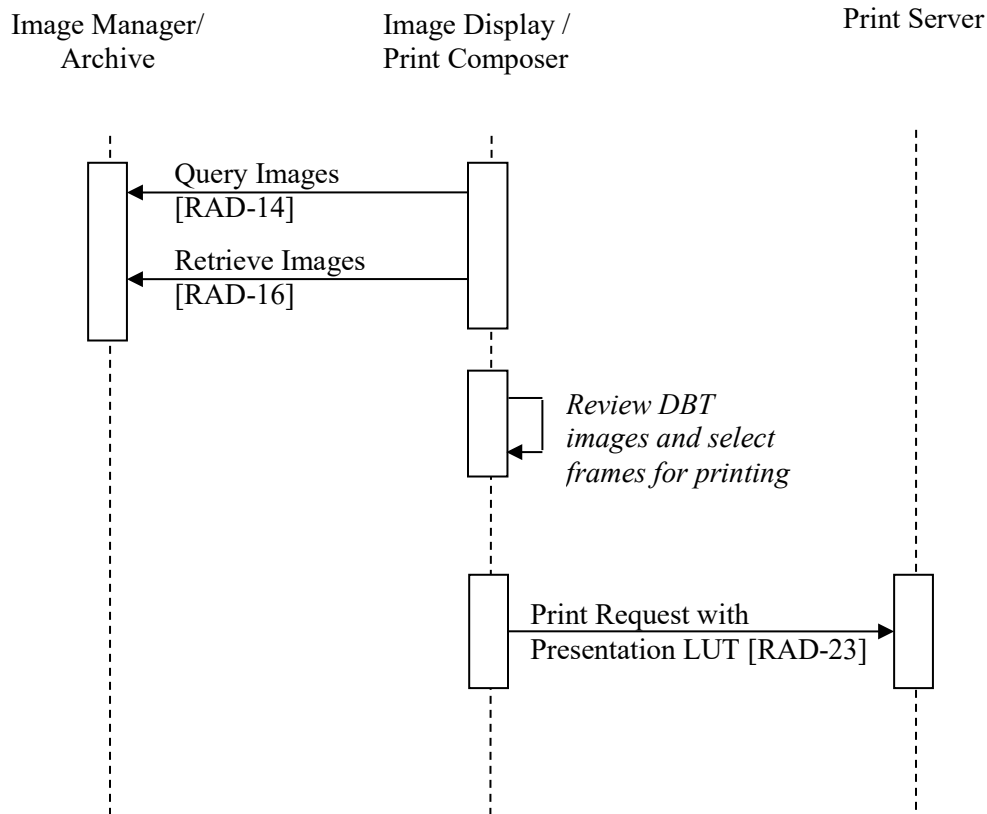

Figure 37.4.2.6.2-1: Process Flow in Printing of Selected DBT Frames Use Case

37.5 DBT Security Considerations

N/A

5875 37.6 DBT Cross Profile Considerations

SWF – Scheduled Workflow

The main focus of the Digital Breast Tomosynthesis Profile is to define creation and review of digital breast tomosynthesis studies including DBT images and conventional 2D mammography images. The scheduling workflow is addressed in the Scheduled Workflow Profile.

5880 **MAWF - Mammography Acquisition Workflow**

The main focus of the Digital Breast Tomosynthesis Profile is to define creation and review of digital breast tomosynthesis studies including DBT images and conventional 2D mammography images. The workflows addressing exception handling scenarios, e.g., converting a screening procedure into a diagnostic procedure, are defined in the Mammography Acquisition Workflow Profile. The workflows defined in that profile are independent of the type of images acquired and therefore apply to studies including DBT images as well.

5885

BIR - Basic Image Review

The Basic Image Review Profile clearly states that specialty viewing (like Mammography) is outside the scope of that profile. Therefore, review of DBT images in the BIR Profile is confined to partial (display – only) support. Specific viewer requirements are addressed in Section 37.2.6.

5890

38 Web-based Image Capture (WIC)

This section intentionally, temporarily left blank.

39 Clinical Decision Support – Order Appropriateness Tracking (CDS-OAT)

5895 This section intentionally, temporarily left blank.

40 Radiation Exposure Monitoring – Nuclear Medicine (REM-NM)

This section intentionally, temporarily left blank.

41 Cross-Enterprise Remote Read Workflow Definition (XRR-WD)

This section intentionally, temporarily left blank.

5900 **42 Web-based Image Access (WIA)**

This section intentionally, temporarily left blank.

43 Standardized Operational Log Events (SOLE)

This section intentionally, temporarily left blank.

44 Management of Acquisition Protocols (MAP)

5905 This section intentionally, temporarily left blank.

45 Results Distribution (RD)

This section intentionally, temporarily left blank.

46 Intentionally Left Blank

This section is intentionally left blank.

5910 **47 Encounter-based Imaging Workflow (EBIW)**

This section intentionally, temporarily left blank.

48 Import and Display of External Priors (IDEP)

This section intentionally, temporarily left blank.

5915

Appendix A: Clarification of Accession Number and Requested Procedure ID

5920 The purpose of this appendix is to clarify the entity relationships in the Model of Real World adopted by IHE and role of the entity identifiers, such as Accession Number and the Requested Procedure ID, that are used to maintain data consistency between those entities.

A.1 Structure of an Order for Imaging Service

5925 There are multiple information systems involved in the fulfillment of the request directed to the imaging department, such as a Radiology Information System (RIS) and a Picture Archiving and Communication System (PACS).

5930 The order for the imaging service is communicated between the Order Placer (such as an Order Entry system) and the Order Filler (such as an RIS). In the imaging department environment, the Order Filler also identifies the set of procedures and sub-procedures (procedure steps) that have to be performed in the process of fulfilling the order. Each procedure step is performed using a single device (modality, workstation). In the process of scheduling the order fulfillment, the Order Filler identifies the type of device and either a specific device or group of devices (for example, by geographic location) one of which is to be used in performing the procedure step.

5935 An Order Filler accepts from an Order Placer a single Order that it equates to a Filler Order (which is concept commonly used in HL7) or Imaging Service Request (Concept commonly used in DICOM). Correspondingly, it will assign a Filler Order Number associated with the order. For the same order to be treated as Imaging Service Request, it will also assign a unique Accession Number. The Accession Number is critical for associating performed procedure steps to the corresponding scheduled procedure steps; therefore, IHE recommends that the Accession
5940 Number rather contains no value than an unreliable value, in order to give a human user the opportunity to timely correct this missing value (see also the Tables in RAD TF-2: Appendix A).

Each Filler Order may contain one or more Requested Procedures. Each Requested Procedure is identified by a Requested Procedure ID that needs to be unique only within the scope of the Filler Order Number/Accession Number.

5945 A Requested Procedure is an instance of a Procedure of a given Procedure Type. An instance of a Requested Procedure includes all of the items of information that are specified by an instance of a Procedure Plan that is selected for the Requested Procedure by the imaging service provider. This Procedure Plan is defined by the imaging service provider on the basis of the Procedure
5950 Plan templates associated with the considered Procedure Type. A single Requested Procedure of one Procedure Type is the highest hierarchical unit of work level that may give rise to the creation of a report. Each report is one of the results produced to satisfy the order. For example, in a case of the order for an X-ray examination of a patient daily at 8 am for the next three days, each of the daily examinations will require a separate diagnostic report; hence each of them will be treated as a separate Requested Procedure. In order to support DICOM Query/Retrieve
5955 mechanism and easy collation of all results pertaining to a single procedure Order Filler also generates the Study Instance UID, a globally unique identifier for each Requested Procedure.

This identifier will be used to identify all generated images and other DICOM objects related to this Requested Procedure.

5960 Performance of one instance of a Requested Procedure is specified by exactly one Procedure Plan. Each Requested Procedure may contain one or more Scheduled Procedure Steps that are to be performed according to the Protocols specified by a Procedure Plan. Type and number of Scheduled Procedure Steps in a Requested Procedure is based on the timing and equipment requirements. Each step is identified with the Scheduled Procedure Step ID. A single Procedure Step may only be performed on a single type and instance of equipment. Thus, while the
 5965 Requested Procedure may identify multi-modality examination (such as ones common in Nuclear Medicine), a single Procedure Step shall correspond to the operations performed on a single modality.

The example of the hierarchy of Imaging Service Request, Requested Procedure and Scheduled Procedure Step is depicted in a Figure A.1-1. Names of entities are represented by names in bolded text, and their identifiers are represented by names in square brackets.
 5970

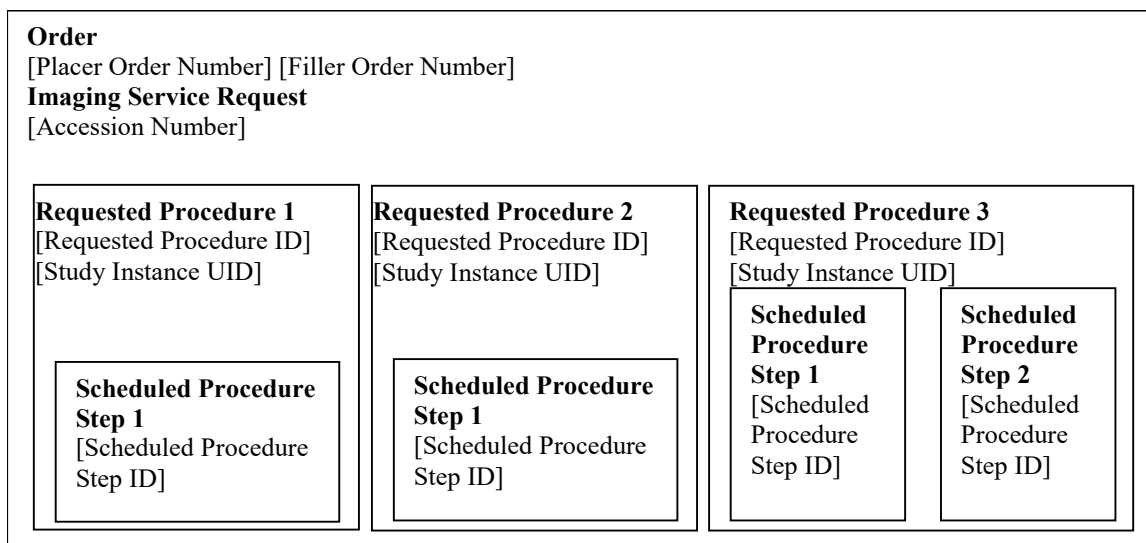

Figure A.1-1: Hierarchy of Components of an Order

5975 **Appendix B: Topics for Standards Corrections or Supplements**

B.1 HL7 Topics

B.1.1 Version 2.5

5980 The IHE Radiology Technical Framework is primarily based on the version 2.3.1 of the HL7 standard (see RAD TF-2: 2.4.4 for discussion of HL7 Versioning). The definitions provided in the Technical Framework will specify the base version of HL7 used. For example, the Appointment Notification [RAD-48] transaction uses the SIU^S12 message first defined in HL7 Version 2.4 in order to take advantage of the additional scheduling information not available in previous versions.

5985 Likewise, IHE has had to provide temporary solutions in custom segments where definitions have not existed. An example is the definition of the [RAD-4] and [RAD-13] transactions which include a ZDS Segment as a temporary solution for handling Study Instance UID. A definition for the Study Instance UID did not exist until HL7 version 2.5 when definitions were added to the OMI (Imaging Order) message.

B.1.2 HL7 Conformance

5990 HL7 in its version 2.5 defines the concepts of HL7 conformance and HL7 profiles that provide standardized mechanism for HL7 specifications. IHE intends to document its definitions of HL7-based transactions using such mechanism. Note that HL7 conformance profiles are not related to IHE Integration Profiles and will be used only for purpose of better documentation of IHE requirements

5995 **B.2 DICOM Topics**

Implementers are expected to keep up with CP's in DICOM as well as in IHE. DICOM CPs may be found here: <http://www.dclunie.com/dicom-status/status.html>

Appendix C: Overview of the Information Exchange between Department System Scheduler/Order Filler and Image Manager

6000

Information exchange between the Department System Scheduler/Order Filler and the Image Manager is performed on the intra-departmental level. Each actor manages a distinct domain of information within a department: patient, order and procedure performance information for the Department System Scheduler/Order Filler; image acquisition, storage and interpretation for the Image Manager. Each system, however, requires valid and current information from both domains.

6005

C.1 Exchange of Patient Information

The Department System Scheduler/Order Filler is a source of patient information for the Image Manager within the context of a department. The Image Manager does not receive information for a particular patient until the first order for a patient has been submitted to the department and corresponding procedures have been scheduled. At this point, the Department System Scheduler/Order Filler will communicate patient information to the Image Manager within [RAD-4] Procedure Scheduled.

6010

Subsequent updates of patient information are communicated by the Department System Scheduler/Order Filler to the Image Manager via the Patient Update [RAD-12] transaction. These changes will be reflected on the Image Manager and in the images, Grayscale Softcopy Presentation State and Key Image Note objects retrieved from the Image Archive. The Image Manager shall not initiate patient information changes.

6015

C.2 Exchange of Visit and Order Information

The Department System Scheduler/Order Filler is a source of visit and order information for the Image Manager. The Image Manager does not receive information for a particular patient's visit until the first order for a patient originated within such a visit has been submitted to the department and corresponding procedures have been scheduled. At this point, the Department System Scheduler/Order Filler will communicate visit and order information to the Image Manager within Procedure Scheduled [RAD-4]

6020

6025

Subsequent updates of visit information are communicated by the Department System Scheduler/Order Filler to the Image Manager via Patient Update [RAD-12]. These changes will be reflected on the Image Manager and in the images, Grayscale Softcopy Presentation State and Key Image Note objects retrieved from the Image Archive. The Image Manager shall not initiate visit information changes.

6030

Because the Radiology Technical Framework requires that the order information change will be performed through cancellation of the order in question and re-order, updates of order information are communicated by the Department System Scheduler/Order Filler to the Image Manager via a sequence of two transactions – Procedure Update [RAD-13] (conveying order cancel) and Procedure Scheduled [RAD-4] (conveying new order information). The Image Manager shall not initiate order information changes.

6035

C.3 Exchange of Procedure Information

6040 The Department System Scheduler/Order Filler is a source of Requested Procedure information for the Image Manager. The Image Manager does not receive information for a particular procedure until it has been scheduled. At this point, the Department System Scheduler/Order Filler will communicate visit and order information to the Image Manager within Procedure Scheduled [RAD-4].

6045 Subsequent updates of procedure information (re-scheduling, change of procedure code, etc.) are communicated by the DSS/Order Filler to the Image Manager via Procedure Update [RAD-13]. The Image Manager shall not initiate Requested Procedure information changes.

6050 In the Scheduled Workflow Group Case (RAD TF-2: 4.6.4.1.2.3.4) and Import Reconciliation Workflow Scheduled Import (RAD TF-2: Table A.5-1), certain imaging information submitted to the Image Manager from the Acquisition Modality or the Importer will differ from that provided by the Department System Scheduler/Order Filler. This information can include the Study Instance UID and the Performed Procedure, Performed Procedure Step and Performed Protocol. For these defined cases this imaging information shall not be subject to change by either the Department System Scheduler/Order Filler or the Image Manager.

6055 The behavior for handling the case where the imaging information differs because the Acquisition Modality does not conform to Scheduled Workflow is not defined.

Appendix D: IHE Integration Statements

For details, please see: [IHE Technical Framework General Introduction Appendix F: IHE Integration Statements](#).

Appendix E: Nuclear Medicine

Note that the NM Image Profile is undergoing revision, and vendors considering implementation are advised to include the modifications contained in the trial implementation version “NM Image Profile with Cardiac Option”. For additional information please contact the IHE
6065 Radiology Technical Committee at ihe-rad-tech@googlegroups.com.

E.1 Introduction

This Appendix provides a description of relevant aspects of Nuclear Medicine in the context of the IHE Radiology Technical Framework. This includes descriptions of some typical Nuclear
6070 Medicine workflows and how they can be supported within the framework of the current Scheduled Workflow and Post-Processing Workflow Integration Profiles. Characteristics of typical NM Images are presented and examples of typical displays of NM Images are provided.

This Appendix is informative, not normative. The mapping of workflows to the IHE Model, and other details of NM practice are sufficiently complex and/or misunderstood that this Appendix
6075 has been included to clarify such issues and provide examples of some sensible approaches. The examples and details here are not intended to be exhaustive. The mappings to the workflow model of IHE shown here are valid but do not represent the only valid mappings.

E.2 NM Workflow Overview

First it should be said that the normal scheduled workflow of:

- registering a patient
- 6080 • placing an order
- scheduling an acquisition
- retrieving a worklist at the modality
- performing an acquisition
- generating images
- 6085 • storing images to the archive
- retrieving images for review
- generating a report

... is certainly applicable to NM studies.

That being said, it is perhaps most instructive to proceed to describe the ways in which NM
6090 workflow can differ from typical radiology workflow and what assumptions may not be valid or may require special consideration for NM.

E.2.1 Injection Steps

6095 All nuclear medicine studies depend on the injection of radio-pharmaceutical tracers (although a given series may be imaging a radio-pharmaceutical injected hours or days earlier). Note that although this document refers to injection of the radio-pharmaceutical, it may also be given orally or by some other route.

6100 The required dose of radio-pharmaceutical must be ordered from the pharmacy and delivery arranged to coincide with the scheduled patient procedure. Other aspects include updates for changed or cancelled orders, tracking the radioactive materials, performing QA and confirming the count levels of the delivered dose, etc.

The injection procedure step itself is also generally scheduled and its execution logged and tracked both because time from injection factors in to most protocols and because the drug administration should go into the patient record.

6105 As will be discussed in the following section on NM Worklist Guidelines, most of these tasks would fall in the scope of yet-to-be-developed profiles relating to Pharmacy and Enterprise Scheduling but the injection step may fall in the scope of Scheduled Workflow.

E.2.2 Time Separated Acquisitions

Standard NM clinical practice includes protocols which require the patient to leave the acquisition equipment between acquisition steps.

6110 Some imaging procedures include multiple acquisition steps separated by some time interval. This time interval can be anywhere from 1 or 2 hours, up to as much as a few days. This means that the patient leaves the imaging system in between parts of the procedure. When the patient returns, it is possible that the new acquisitions may be done on a different system based on availability. Therefore, there can be no assumption that the same acquisition system is involved in all steps of a given procedure.

6115 On the other hand, some protocols may involve several acquisition steps done at-once, back-to-back.

E.2.3 Reconstruction as a Separate Operation

6120 NM differs from other modalities in the relationship between acquisition and reconstruction processes.

In most modalities the raw acquisition data has little clinical use. Reconstruction is generally performed on the modality and only the reconstructed images are exported from the modality.

For NM studies, the raw projection images are clinically useful images, and are often exported and viewed using the NM IOD.

6125 When these projection images are tomographic (i.e., Image Type = TOMO or GATED TOMO) they can also be reconstructed into volume images similar to CT or MR images, i.e., a stack of slices. Although this reconstruction process can be done on the acquisition system as is done in most modalities, due to the availability of exported tomographic images, it may also be done on

6130 other workstations depending on site preferences for particular vendors reconstruction algorithms, processing loads, and other workflow issues.

E.2.4 Acquisition Post-Processing

In addition to reconstruction, there are a number of other acquisition related processing steps performed on the acquired images. This includes:

- Uniformity Correction - to correct for non-uniformities in the detector hardware
- 6135 • Decay Correction - to correct for radioactive decay of the injected tracer over time
- Scatter Correction - to remove photons scattered by tissue rather than emitted by the tracer
- Attenuation Correction - to compensate for photons absorbed within the body
- Patient Motion Correction - to compensate for patient motion during the scan
- 6140 • Center of Rotation Correction - to compensate for offsets in the axis of rotation

Other possible corrections include deadtime, energy and linearity.

Some of these corrections, especially those that are hardware dependent or are specific to an acquisition system, must be performed on the acquisition modality if they are performed at all. To avoid encouraging potentially incomplete attempts to carry out these corrections away from the modality, the NM IOD intentionally leaves out attributes for attempting to convey all the relevant information.

6145

Other steps, although generally performed on the acquisition modality, may, like reconstruction, be performed on a separate workstation depending on system capabilities and site preferences.

E.2.5 Clinical Post Processing

6150 Finally, due to the metabolic/qualitative nature of NM imaging, it is very common to perform clinical processing on the images to extract quantitative details prior to final review.

These clinical processing packages too are sometimes available on the acquisition modality but may also be on a separate workstation. This processing includes things like:

- Re-orientation of volumes
- 6155 • 2D and/or 3D segmentation (automatic and/or manual)
- Calculation of region characteristics
- Generation of time-plots
- Computation of functional images
- Generation of Result Screens

6160 These activities are sometimes performed immediately following acquisition or may be left for batch processing at a later time.

E.2.6 Display and Reviewing

6165 Unlike other modalities where the raw acquisition data has little clinical use, for NM images, the raw projection images are clinically useful images, and are often reviewed by the reading radiologist together with processed results.

Also, the color presentation of the images is common in Nuclear Medicine and is a clinical necessity for the interpretation of certain images.

E.2.7 Workflow Chaining

6170 Due to the common use of processing workstations and clinical processing before reporting, the work on chained workflows being discussed in the IHE Radiology Technical Committee whitepaper on Departmental Workflow will be of particular interest and relevance to Nuclear Medicine.

E.3 NM Worklists

6175 The following informative text provides guidance on how NM activities would most logically be mapped to IHE Worklists and the concepts of Scheduled and Performed Procedure Steps.

The Scheduled Workflow Profile and Post-Processing Profile are very flexible in allowing complex procedures to be scheduled as a single procedure step (potentially with multiple procedure codes) or as multiple procedure steps. There are some situations which can work equally well with either approach, and ultimately sites will need to have some flexibility in how the work is scheduled in order to fit their work patterns.

6180 That being said, the following are some basic guidelines which represent a sensible approach that should be considered. After the guidelines are a number of examples of how the guidelines would be applied to cases taken from typical clinical practice.

E.3.1 NM Worklist Guidelines

E.3.1.1 Injections

6185 Scheduling, preparing, tracking and delivering the required dose of radio-pharmaceutical tracer is the job of the pharmacy and it does not make particular sense to include it in the worklists currently managed by the Radiology Profiles. It would make sense to address this in future Pharmacy and Enterprise Scheduling Profiles which would also handle related issues, such as changing or canceling the order, managing drug interactions, QA and tracking of radioactive materials, etc.

The injection procedure step itself may also be scheduled and is frequently performed in proximity to the imaging equipment and in the presence of, or by, the modality operator.

6195 As a practical matter, pending development of the above-mentioned profiles, it would be useful and not unreasonable for the DSS/Order Filler and the Acquisition Modality to allow injection steps to be placed on the Modality Worklist, either as procedure codes in an acquisition procedure step or as an independent procedure step.

6200 Further, the modality could allow the operator to indicate that the injection has been completed and generate corresponding MPPS details. Supporting codes for injections is not a requirement, but would be a useful feature. Note that the NM Image IOD already has attributes in the NM Isotope Module for modality systems that track injection details.

If the injection step is to be performed at the time of an acquisition, then it would be appropriate for the injection to be included as one Item in the Protocol Code Sequence within the Scheduled Procedure Step for the acquisition.

6205 Injections that are performed outside of the acquisition room, some time prior to the data acquisition, are not particularly appropriate for inclusion in a modality worklist and are out of scope of this discussion.

6210 While charges for radio-pharmaceuticals are generally built into the technical procedure fee, it would be appropriate and sometimes useful to include details about the radio-pharmaceutical dose in the Billing and Material Management Option described in RAD TF-2: 4.7. In cases where the MPPS indicates the procedure was cancelled, if an injection was still performed, it would be appropriate to include that information in the MPPS.

E.3.1.2 Acquisitions

6215 It is suggested that, in general, each acquisition of image data be scheduled as a separate procedure step.

6220 Clinical protocols that include having the patient leave the acquisition system between acquisition steps, must schedule them as separate Scheduled Procedure Steps. However, when several acquisition steps are done at-once, back-to-back, they can either be scheduled as multiple Scheduled Procedure Steps, or as a single Scheduled Procedure Step with multiple protocol codes. Scheduling using multiple Scheduled Procedure Steps allows the greatest flexibility in use of available equipment and the greatest detail in status reporting. Of course, the acquisitions will still likely be part of the same Study with the same Study UID.

6225 Note that support of multiple Scheduled Procedure Steps resulting from a single Requested Procedure is already required in the Scheduled Workflow Profile, but support of multiple protocol codes is optional. Support for multiple performed protocol codes in the Performed Procedure Step is recommended.

6230 An issue worth mentioning is that due to studies involving multiple acquisitions, several acquisition modality systems may participate in the same study. While the Study Instance UID is obtained from the Worklist by both modalities and will be correctly included, the rest of the Study level information, such as study date/time, study description, etc., is generally not provided in the Worklist. This means that each modality will generate their own values and include them in the generated images, resulting in Series instances in the same Study which have different Study level information (except the UID). It is assumed that the Image Manager/Archive will manage any issues related to this.

6235 **E.3.1.3 Reconstruction**

It is recommended that the reconstruction of acquired (tomographic) image data be treated as a separate Performed Procedure Step. That is, the acquisition system should issue a Performed Procedure Step Complete message when the tomographic acquisition is complete.

6240 Then, whatever system performs the reconstruction of this data, whether it is the original acquisition system, or some other system, should issue a new Performed Procedure Step for the reconstruction process, related to the same Scheduled Procedure Step. In this way, scheduling of tomographic acquisitions is consistent with other modalities like CT, but allows the reconstruction to be performed flexibly by any system.

6245 These Reconstruction steps, and other post-processing, may be carried out as explicit workflow by placing them on worklists as outlined in the Post-Processing Workflow Profile, or may be carried out as implicit workflow by the operator knowing these steps should follow acquisition as outlined in the Scheduled Workflow Profile.

E.3.1.4 Acquisition Post-Processing

6250 Due to the nature of Acquisition Post-Processing, as described in Section E.2.4, it will almost always be performed on the acquisition system or on a workstation bundled with the acquisition system. While it is conceivable that some batch-oriented site workflows could benefit from doing these steps with an explicit worklist, the vast majority of sites will do these steps as implicit workflow. Further, the acquisition post-processing steps are seldom billable and there is little need for detailed tracking of these steps.

6255 If the processing is performed on a separate workstation the steps should be considered as separate procedure steps but there is likely only a need to create Performed Procedure Step messages when the step creates new images which will be sent to the Image Manager/Archive.

If the processing is performed on the acquisition modality system, which is the most likely, it is acceptable to include the steps as additional protocol codes.

6260 **E.3.1.5 Clinical Post-Processing**

Clinical Post-Processing, as described in Section E.2.5, may be done at some sites using explicit workflow, although many sites will handle it with implicit workflow.

6265 If the processing is performed on a separate workstation the steps should be handled as separate procedure steps, either scheduled as explicit workflow as described in the Post-Processing Workflow Profile or unscheduled as implicit workflow as described in the Scheduled Workflow Profile.

If the processing is performed on the acquisition modality system it is acceptable to include the steps as additional protocol codes, however it is recommended to handle them as separate procedure steps.

6270 **E.3.2 NM Worklist Examples**

The following are some examples of clinical situations and an example of an appropriate way to handle them based on the above guidelines.

E.3.2.1 Injection and immediate imaging

Example: Renal scan (Dynamic)

6275 The patient is injected under the camera, and imaging is started immediately.

Use a single SPS which includes protocol codes for the injection and for a single acquisition.

E.3.2.2 Injection and delayed imaging

Example: Bone scan to assess for malignancy (Static or Whole body)

6280 The patient is injected somewhere (could be in the imaging department or at the patient bedside), and images are obtained several hours later.

Use a single SPS which includes a single acquisition. The injection details are handled out of scope.

E.3.2.3 Injection with both immediate and delayed imaging

Example: 3-phase bone scan for infection (Dynamic and Static)

6285 The patient is injected under the camera, and imaging is started immediately. More images are obtained several hours later, on the same or a different gamma camera.

Use two SPS. The first SPS includes protocol codes for both the injection and the initial dynamic and static acquisitions. The second SPS is for the second static acquisition. Images acquired from the second SPS must be in a different Series from those from the first SPS.

6290 **E.3.2.4 Injection and immediate imaging, with possible further imaging**

Example: Renal scan to evaluate for obstruction, with possible second diuretic acquisition (Dynamic)

The patient is injected under the camera, and imaging is started immediately. The results will determine whether more imaging is needed.

6295 Schedule two SPS as in E.3.2.3. The images from the first SPS can be read, and then a determination can be made as to whether or not the second acquisition is required. If it is not needed, then the second SPS can be cancelled at the modality by issuing an MPPS aborted message.

E.3.2.5 Injection and very delayed imaging

6300 Example: I-131 whole body imaging (Whole body)

The patient dose is given, and images obtained days later.

Optionally schedule one SPS for the injection if it is performed in the imaging suite. An SPS would be scheduled for the acquisition.

E.3.2.6 Imaging and no injection

6305 Example: Add-on imaging after therapeutic administration by radiation oncology (Static or Whole body)

The patient dose is given by someone else in the radiation oncology department for the purpose of therapy. Several days later, imaging is performed for evaluation purposes.

A single SPS is used for the image acquisition.

E.3.2.7 Two isotope examination, with two imaging times

6310 Example: Dual isotope [Thallium-201 “rest” images & Tc-99m Sestamibi “stress” images] myocardial perfusion study (Gated Tomo)

The first isotope is injected followed by image acquisition. A second isotope (possibly under different patient conditions) is subsequently injected followed by a second image acquisition (possibly on a different camera).

6315

This protocol uses two SPS. The first contains protocol codes for the first injection and the first acquisition. The second SPS contains protocol codes for the second injection and acquisition. Each of these two acquisitions constitutes a separate Series.

It should be noted that these are simply suggestions of one approach that makes sense. Sites will of course be interested in scheduling in ways that make sense to them. It is conceivable that an ECG or Treadmill might implement Modality Worklist, allowing their activities to be scheduled and monitored steps, however such actors do not currently exist in the framework and such implementations are currently unlikely.

6320

E.3.2.8 Two isotope examination, with single imaging time

6325 Example: Dual isotope [In-111 labeled White blood cell “infection” images & Tc-99 sulfur colloid “bone marrow” images] infection study (Dual Energy Static or Whole body)

In this example the first isotope is injected on day one. Then the following day the second isotope is injected 30 minutes before the acquisition step which images both isotopes.

Consider three SPS. The first SPS (optional) for the first injection, the second SPS for the second injection, and the third SPS for the actual acquisition.

6330

Note that this case might result in billing for two exams (White Blood Cell study and Bone Marrow imaging), but most centers would actually only issue a single report, since there was only one imaging step. This is sort of like the case where an abdomen and pelvis CT was done as a single acquisition, and then read by the same person, but billed as two "studies" (i.e., the PGP Profile).

6335

E.3.2.9 Acquisition and Reconstruction on the Acquisition Modality

Example: Cardiac Tomographic acquisition followed by basic corrections, reconstruction and re-orientation to align the volume with the cardiac Short Axis.

6340 A single SPS is created which calls for one cardiac tomographic acquisition. The modality performs the acquisition and sends an MPPS Complete message, referencing the created tomographic images.

The modality then does corrections and reconstruction of the tomographic data, appends a new MPPS and reports it complete, without referencing the intermediate image data.

6345 Finally, the reconstructed data is re-oriented into cardiac Short Axis images and the modality appends a third MPPS to report the reformatting processing, and referencing the re-oriented slices.

The initial tomographic images and the final re-oriented slices are stored to the Image Manager/Archive.

6350 This example raises a point that is sometimes overlooked. MPPS transactions should only include references to series/images which will be (or have been) sent to the Image Manager/Archive. The implication of including the references is that they will be sent to the Image Manager/Archive. Correspondingly, the Image Manager/Archive will be waiting for all referenced images and may continue to consider the study incomplete until they arrive. Thus, referencing images which will not be sent can have the effect of derailing the workflow.

6355 E.3.2.10 Re-orientation on an Evidence Creator with Implicit Workflow

Example: Same as the previous case, but all of the processing takes place on a separate Evidence Creator based on implicit workflow as described in Scheduled Workflow.

A single SPS is created which calls for one cardiac tomographic acquisition. The modality performs the acquisition and sends an MPPS Complete message.

6360 The modality then does corrections and reconstruction of the tomographic data, appends a new MPPS and reports it complete.

The initial tomographic images are stored to the Image Manager/Archive and the reconstructed slices are stored to the Evidence Creator workstation.

6365 The workstation re-orientates the reconstructed data into cardiac Short Axis images and sends a new MPPS to the PPS Manager. The SPS and patient references in the created images and MPPS are copied from the information in the received slice images.

The Evidence Creator stores the final re-oriented slices to the Image Manager/Archive.

E.3.2.11 Re-orientation and Post-Processing on an Evidence Creator with Explicit Workflow

6370 Example: Same as the previous case, but the work is placed on a Post-Processing Worklist and the Evidence Creator also performs post-processing that produces some Result Screens.

A single SPS is created on the Post-Processing Worklist with codes for Re-orientation and Clinical Result Processing.

6375 When the task is selected and the inputs are available on the Evidence Creator, the re-orientation is performed followed by Clinical Result Processing. The Evidence Creator sends an MPPS Complete for the two codes.

The re-oriented slice images and result screens are stored to the Image Manager/Archive.

6380 The timing of placing the SPS on the Post-Processing Worklist is not discussed here as that is the topic of an IHE Radiology Technical Committee whitepaper on Departmental Workflow and is still under discussion.

6385 In the above two cases, data was considered to be pushed from the Acquisition Modality to the Evidence Creator. This is a typical practice, but it should be noted that the mechanism for this is not specified by IHE. The processing system may retrieve the images from the acquisition modality, the acquisition modality may push them to the processing system, or the Image Manager/Archive could be used as a common storage and retrieval point.

6390 Also, applications that perform clinical post-processing often need to identify specific related series to use as inputs for processing (for example the corresponding stress and rest series for a cardiac study). The software should look to the DICOM fields to determine the patient state and type of Image. The information in the fields may be utilized automatically by the software or may be presented to the user for manual selection.

E.4 NM Data

The NM Image IOD (refer to DICOM PS 3.3 C.8.4) supports several NM Image Types as indicated by the code contained in Value 3 of the Image Type (0008,0008) attribute.

The currently allowed Image Types are:

6395 **STATIC** - Simple projection image containing one or more frames (e.g., individual views of the lungs).

WHOLE BODY - Projection image where each frame spans the length of the body (e.g., an anterior and/or posterior view of the body).

6400 **DYNAMIC** - Projection image containing a series of frames typically showing the same anatomy over time (e.g., a view of renal isotope uptake and washout).

GATED - Similar to **DYNAMIC**, except the frames are composed to span phases of a gated interval (e.g., a beating view of the heart).

TOMO - Projection image with frames take from various angles as the detector rotates about the patient. Generally used to reconstruct volume slices.

6405 **RECON TOMO** - Reconstructed image with frames corresponding to cross-sectional slices covering a volume. Created by reconstructing **TOMO** image frames.

GATED TOMO - Similar to **TOMO**, except each angle has multiple frames representing the phases over a gated interval. Generally used to reconstruct gated volume slices.

6410 RECON GATED TOMO - Reconstructed image with frames corresponding to cross-sectional slices covering a volume at each phase of a gated interval (e.g., a beating heart volume, created by reconstructing GATED TOMO image frames).

6415 In the NM IOD the information about the orientation and position of the acquired image (frame) is placed in the description of the acquiring detector. So, if the same physical detector acquires data at several locations, there will be separate detector description for each position. Because of this, the detector description in the NM IOD is that of a logical detector. Most NM acquisition modalities have 1, 2, or maybe 3 physical detectors. But an NM object created by these modalities may contain considerably more logical detectors in cases where the acquisition system is moved or rotated about the patient.

E.4.1 Study UIDs and Series UIDs

6420 The basic guidelines for creating Study, Series and SOP UIDs are provided in RAD TF-2: 4.8.4.1.1.1.

6425 While the decision as to what constitutes a new Series is traditionally left to the modality, it can be said that a series contains images that represent the output of a single procedure step on a single piece of equipment with a single patient positioning. In practice, the series has frequently been used to collect a group of single-frame IODs such as the CT slices making up a volume.

In multi-frame IODs such as NM, this is not necessary, as related frames are generally already grouped together in the multi-frame IOD. Therefore, it is strongly recommended that each separate acquisition should become a new Series.

6430 Stress and rest cardiac exams separated by a time delay, potentially of hours, should be separate Series since they may be scheduled separately, could be performed on different acquisition systems, and may not be able to position the patient identically.

Similarly, reconstruction or post-processing steps must be different Series if they are done on different workstations. For consistency, it is required here that they always be placed in different Series.

6435 It is also recommended that when new results are produced by doing the same processing on the same data (for example, to reprocess with slightly different parameters), then each repetition of the processing step should result in images that are part of a new Series.

6440 Processing functions that produce multiple Images from a single processing step (for example, several static SC Images, multiple reconstructed views, etc.) should use the same Series for all of the Images.

It is recommended that object creators fill the Series Description attribute with a value that would indicate to users the nature of the contents of the object. In particular the value should help in differentiating Series in the same Study. The Series Description is reasonably well supported by PACS systems, while image level fields are less widely supported.

6445 **E.4.2 NM Image IOD: Multi-Frames and Vectors**

It is important to understand that although single-frame DICOM images are most common in current use in other modalities, the DICOM Nuclear Medicine Image IOD is a multi-frame image. This means typically an Image will contain multiple 2-D pixel arrays called Frames. Refer to DICOM PS3.3 C.8.4.8 for details.

6450 The object becomes more complex due to the fact that each frame is indexed according to a number of acquisition “dimensions” such as Energy Window, Detector, Angle and Phase. Each frame is indexed in each dimension by a “Frame Pointer” vector.

An example of the Frame Increment Pointer vectors for a Dynamic Image is shown here (taken from DICOM PS3.3 C.8.4.8.1):

6455 The Pixel Data (7FE0,0010) would contain the frames in the following order:

Frame	1	2	3	4	5	6	7	8	9	10	11	12	13	14
Energy Window #	1	1	1	1	1	1	1	1	1	1	1	1	1	1
Detector #	1	1	1	1	1	1	1	2	2	2	2	2	2	2
Phase #	1	1	1	1	1	2	2	1	1	1	1	1	2	2
Time Slice #	1	2	3	4	5	1	2	1	2	3	4	5	1	2

and the four vectors would be defined as:

Energy Window Vector = 1,1,1,1,1,1,1,1,1,1,1,1,1,1,1

Detector Vector = 1,1,1,1,1,1,1,2,2,2,2,2,2,2,2

6460 Phase Vector = 1,1,1,1,1,2,2,1,1,1,1,1,2,2

Time Slice Vector = 1,2,3,4,5,1,2,1,2,3,4,5,1,2

Each vector attribute has a matching “Number Of” attribute indicating how many values are enumerated in the corresponding vector. In the above example the Number of Energy Windows = 1 indicating that only one energy window was used so all the entries in the Energy Window Vector will contain the same value.

6465

For each NM Image Type, the DICOM standard specifies the frame increment pointers which must be present and the order in which the pointer vectors are stored. Typically, the last vector will vary most rapidly, although exceptions exist. The NM Image Type is stored in Value 3 of the Image Type attribute (0008,0008).

6470 **E.4.3 Typical NM Data Dimensions**

Typical sizes of NM Image frames and NM Image vectors are provided in the following table.

Table E.4-1: NM Image Characteristics

Image Type	Typical Matrix Size	Frame Increment Pointer [i.e., vectors]	Typical #
STATIC	128 x 128 256 x 256	Energy Window (0054,0010)	1 - 2
		Detector (0054,0020)	1 - 2*
		[Total Frames]	1 - 12*
WHOLE BODY	1024 x 256 1024 x 512	Energy Window (0054,0010)	1 - 2
		Detector (0054,0020)	1 - 2
		[Total Frames]	1 - 4
DYNAMIC	64 x 64 128 x 128	Energy Window (0054,0010)	1 - 2
		Detector (0054,0020)	1 - 2
		Phase (0054,0100)	1 - 3
		Time Slice (0054,0030)	1 - 120
		[Total Frames]	1 - 1440
GATED	64 x 64 128 x 128	Energy Window (0054,0010)	1
		Detector (0054,0020)	1
		R-R Interval (0054,0060)	1
		Time Slot (0054,0070)	8 - 32
		[Total Frames]	8 - 32
TOMO	64 x 64 128 x 128	Energy Window (0054,0010)	1
		Detector (0054,0020)	1
		Rotation (0054,0050)	1
		Angular View (0054,0090)	30 - 128
		[Total Frames]	30 - 128
GATED TOMO	64 x 64 128 x 128	Energy Window (0054,0010)	1
		Detector (0054,0020)	1
		Rotation (0054,0050)	1
		R-R Interval (0054,0060)	1
		Time Slot (0054,0070)	8 - 16
		Angular View (0054,0090)	30 - 128
		[Total Frames]	240 - 2048
RECON TOMO	64 x 64 128 x 128	Slice (0054,0080)	12 - 128
GATED RECON TOMO	64 x 64 128 x 128	R-R Interval (0054,0060)	1
		Time Slot (0054,0070)	8 - 16
		Slice (0054,0080)	12 - 24
		[Total Frames]	96 - 384

* Note that although the number of physical detectors is generally 1 or 2, the object may potentially contain a separate logical detector for each frame in the image as described in the last paragraph of Section E.4 above.

6475

E.5 NM Display

E.5.1 NM Intensity and Color Mapping

6480 The control of display intensities in Nuclear Medicine is different than that used for CT or MR images due to inherent differences in the modality imaging process and the resulting image characteristics.

In CT images are characterized by the fact that the pixel values represent Hounsfield units. Bone is represented by a well-known value plus or minus a typical range. Soft tissues are represented by another well-known value plus or minus a range. In this space it makes sense to provide controls for selecting a Window Center and a Window Width.

6485 In NM images, the pixel values typically represent radioactivity “counts”. Due to differences in radiopharmaceutical type, dose, time between injection and imaging, length of scan, overlying tissue density, metabolic processes and many other things, the pixel values cannot be considered strictly quantitative. Further, the image is often characterized by very high intensity “hot spots” where a very high concentration of tracer may have accumulated; and by a low level of background activity (“noise”) from non-specific uptake and scatter. For such images, it is appropriate to provide a control that would allow setting a threshold level to cut out the low level background, and another threshold to cut off the high level hot spots which might otherwise obscure mid-range intensities.

6490 Control of NM display intensities is therefore based on Upper and Lower Window Levels. These are different than Window Width and Center but the two are readily interchangeable by a simple linear mathematical transform.

$$\text{Window Upper} = \text{Window Center} + \frac{1}{2} \text{Window Width}$$

$$\text{Window Lower} = \text{Window Center} - \frac{1}{2} \text{Window Width}$$

Or conversely,

6500
$$\text{Window Width} = \text{Window Upper} - \text{Window Lower}$$

$$\text{Window Center} = (\text{Window Upper} + \text{Window Lower}) / 2$$

NM pixel values can generally be represented in 16 bits of data. The Window Upper and Lower Levels indicate the current range of pixel values of interest. It is recommended that the upper and lower window values be displayed in the interface.

6505 Some NM datasets may contain very high pixel values. To display the images, it is generally necessary to map the NM Image pixel values into the range of grey levels which can be displayed by the hardware (most displays have much fewer discernible grey levels than there are pixel values in the dataset).

6510 Generally, the display should be able to map pixel values to at least 128 display intensity levels. If the display supports more display intensity levels, the ability to map to more levels is preferred, if the display is only capable of fewer display intensity levels, it is acceptable to map to fewer levels. Mapping to 64 display intensity levels is also acceptable if it is necessary to display multiple color scales (see below) at the same time.

6515 If the mapping is done only once when the image is first loaded then the presence of a small number of very high pixel values will result in most of the available display levels being “wasted” on a small number of pixels, leaving very little contrast in the rest of the image.

6520 To make effective use of the available display intensity contrast, it is useful to do rescaling after each Window Level adjustment, or to provide a way to control the maximum pixel value used for mapping. A similar problem (and solution) occurs when switching between examining bone and soft tissue windows in a CT image.

If presentation state information is available with the images, it is generally preferred to use it for the initial display. Note that the Window Center and Window Width attributes in the presentation state object will also map to Upper and Lower Window values as described above.

6525 In the absence of presentation state information, it would make sense to display the framesets initially with the Upper and Lower Window Levels set based on the algorithm above and the values stored in the Window Center (0028,1050) and Window Width (0028,1051) attributes of the image data.

6530 In the absence of Window Center and Width values, a possibly viable setting may be the Lower Window level set to zero and the Upper Window Level set to the maximum pixel value of the frameset.

Typical Nuclear Medicine clinical practice also differs from CT and MR in the prevalence of applying pseudo-color lookup tables or “color-scales” to the grayscale data during review. This is done to enhance particular features of the data in certain ways.

6535 Different sites, and sometimes different radiologists within each site, will generally have strong preferences about which color-scales they use for various pathologies in various types of NM studies. It is not unusual for NM review stations to have dozens of color-scales available.

6540 The ability for users to edit and/or create new pseudo-color lookup tables on the Image Display is occasionally useful but not required. Far more useful is the ability to install a preferred collection of color-scales on the system. The Society of Nuclear Medicine (SNM) has plans to act as a repository for a collection of common and popular color-scales.

6545 Since exported Result Screens in NM almost always contain image data, many users will want to be able to apply a pseudo-color lookup table and the ability to adjust Upper and Lower Window Levels of monochrome Secondary Capture and Multi-Frame Secondary Capture Images which have a modality type of NM. It may be unavoidable and would generally be acceptable that this could change the display values for any included graphics and annotations.

E.5.2 NM Image Resizing

6550 NM Images typically range in size from 64x64 to 512x1024 with the majority of the frames at the smaller end of the spectrum. Such small images must be enlarged on the display to be clinically useful, adding unnecessary steps to the reading radiologists’ workflow. A common mistake of general-purpose display systems is to initially display these 64x64 frames at “full resolution” which results in a screen of “postage stamps”.

Correspondingly, Whole body Image frames should generally not be scaled down for initial display, unless such scaling is needed to fit the whole body frame onto the screen.

6555 The following table provides some guidelines on appropriate default zoom factors for various frame sizes. These are intended to simply provide a starting point for systems without sophisticated layout algorithms.

Table E.5-1: Frame Zoom Guidelines

Actual Frame Size	Default Display Size	Default Cine Size
32x32 to 63x63	Display at 4x	Cine at 4x
64x64 to 100x100	Display at 3x if 12 or fewer frames Display at 2x if greater than 12 frames	Cine at 4x
101x101 to 200x200	Display at 2x if 12 or fewer frames Display at 1x if greater than 12 frames	Cine at 3x
201x201 to size of display area	Display at 1x	Cine at 2x (if display area permits) Cine at 1x otherwise
Greater than display area	Shrink to fit in display area	Shrink to fit in display area

6560 Note that while NM images are generally square, they are not required to be so, and it would be appropriate to use just the larger of the x and y dimensions when deciding the zoom factor.

6565 Obviously, there is interplay between the number of frames to display, frame size, zoom factor, and display layout. For example, increasing the zoom from 2X to 3X will result in fewer rows and columns of frames available for display at a given time. Image Displays are encouraged to make intelligent use of display space. Note that horizontal scrolling is preferable to scrolling both vertically and horizontally.

6570 With the above table as a starting point, most users will want to have a way of selecting the display size for the frames. A simple selection of 2X, 3X or 4X zoom may be sufficient. Alternatively, selecting a display format (such as 2x2, 8x8, 4x1, etc.) is also acceptable, though a much wider range of such formats may be needed for NM images than for other modalities, given the small NM image size. Some systems have an option for image magnification, where the size of the displayed area on the screen remains unchanged, but as magnification is increased, less and less of the image is shown, but the portion that is shown is displayed in greater detail. For example, on a femur bone x-ray, one might magnify a portion of the screen to just see the hip portion of the femoral bone, in order to see it at greater resolution. Such magnification is rarely used in nuclear medicine, with the possible exception of the Whole Body images. Such Whole Body images are typically 1024 pixels in height, and may not fit on the screen if a larger zoom is employed. In such cases, it may be necessary to magnify the contents of the frame instead, and

allow the user to designate in some manner the portion of the frame he wants to center on as the magnification is increased.

6580 **E.5.3 NM Display Examples**

E.5.3.1 Example Layouts

The following are example layouts illustrating the different Display Formats identified in RAD TF-2: 4.16.4.2.2.3.2. These are only intended as illustrative examples.

Grid Display

6585

A ₁	A ₂	A ₃	A ₄	A ₅	A ₆	A ₇	A ₈
A ₉
...
...	A ₃₂ ...

Comparison Display (2 Framesets)

A ₁	A ₂	A ₃	A ₄	A ₅	A ₆	A ₇	A ₈
B ₁	B ₂	B ₃	B ₄	B ₅	B ₆	B ₇	B ₈

6590

or alternatively,

A ₁	A ₂	A ₃	A ₄	A ₅	A ₆	A ₇	A ₈
A ₉	A ₁₆

B ₁	B ₂	B ₃	B ₄	B ₅	B ₆	B ₇	B ₈
B ₉	B ₁₆

Whole body Display (2 Framesets, 2 Frames each)

A ₁	A ₂	B ₁	B ₂
----------------	----------------	----------------	----------------

6595 Fit Display (3 images, from 3 series with two frames each)

A ₁	A ₂	B ₁	B ₂
C ₁	C ₁		

MPR Display (one transaxial volume, with a supplied or generated MIP cine display)

6600

Transaxial	Sagittal
Coronal	MIP (cine)

Note that the MIP is not strictly part of the MPR display, but since it is frequently useful, some vendors provide it.

6605

or alternatively,

Coronal y - 1	Coronal y	Coronal y + 1
Axial z - 1	Axial z	Axial z + 1
Sagittal n - 1	Sagittal n	Sagittal n + 1

Cine Display (three images from 3 series, each cycling synchronously)

A ₁₋₃₂	B ₁₋₃₂	C ₁₋₃₂
-------------------	-------------------	-------------------

E.5.3.2 Clinical Examples

6610 This section provides examples and clarifications on typical patterns of display for NM Images. This section should not be considered as an attempt to address hanging protocols. This is a complex topic which DICOM is working on. Once that work is complete, NM and Radiology in general would benefit from that work being included in the IHE Framework. This section is not intended to supplant that.

6615 See RAD TF-2: 4.16.4.2.2.3 for a description of some of the display related capabilities referred to in these examples.

Example 1: Cardiac Study

The user selects a Tomo stress series, several static result screens (secondary captures), another Tomo rest series, and a dynamic result screen (multi-frame secondary capture).

6620 The user would like to see both Tomo images together in a Row Display and be able to view them synchronously in Cine display, preferably with a method for adjusting the cine speed.

Next the user would like to step forward and backward through each of the secondary capture result screens (which may be stored in a set of Secondary Capture images or in a single Multi-Frame Secondary Capture image without a cine module).

6625 The user would also like to review the dynamic result screen in cine mode. It is useful to be able to adjust the cine speed. Systems unable to cine the result screen at 8 frames/sec or faster would have limited clinical usefulness.

Example 2: Lung Perfusion Study

6630 The user selects 4 Static series containing a total of 8 frames. The user would like to see all 8 frames in a Fit Display (preferably with the frames resized to 256x256)

Example 3: Ventilation-Perfusion Study

6635 The user selects the (several) series corresponding to lung perfusion imaging, and the (several) series corresponding to a lung ventilation imaging. The user expects to be able to review the ventilation and perfusion frames together in a Fit Display. The user may wish to adjust each series' intensities and the zoom factor.

It may be useful to select several series and adjust the intensities together.

Example 4: Gastro-intestinal Bleed Study

6640 The user selects 2 dynamic images containing anterior and posterior frames from a two-phase 90 minute gastro-intestinal bleeding exam, with a grand total of 300 frames. The user expects to be able to page through the frames (showing them all at once would make the frames too small) in a Grid Display.

The user would also expect to select one or other view, or one of the phases and view the frameset in a Grid Display.

6645 Finally, the user would view a cine (perhaps two cines, one anterior frameset and one posterior frameset, or a single cine that allows the user to cine one view or the other independently).

Example 5: Renal Study

The user selects a dynamic study. The user expects to see a Grid Display to page through the frames and to be able to cine the time vector.

6650 When more than one phase is present, it is useful to be able to control the upper and lower levels of the phases separately. A user may wish to select a frame set corresponding to the first phase of a Dynamic Image, which represents the flow portion of the exam, and lower the Upper Window Level to increase the visibility of these “low-count” frames. The second phase frame set, which contains images which are inherently much brighter, should be left unadjusted.

In general, typical display formats for each of the NM Image Types would be as follows:

6655 **STATIC:** Simple display. Typically, several images displayed at once (for example in a Fit display). While the default order of frames in the object is sorted by Energy Window then Detector, it is generally more useful to present them in Detector/Energy Window order or sorted by acquisition time. Example: 12 view static

WHOLE BODY: Side by side display of two rectangular images (i.e., the Whole Body display).

6660 **DYNAMIC:** Cine through all frames of all phases from one detector and one energy window, in order. It is also useful to display in a Grid or Row display. Generally, a different window level applies to each phase. Processing (not required by the NM Profile) includes plotting time activity through user selected areas of the image.

6665 **GATED:** Cine through the frames from one detector/energy window, in time order. Processing (not required by the NM Profile) can include time activity curves, heart wall edge detection and motion tracking, etc. Typically, several images displayed at once.

TOMO: Cine all frames from one (logical) detector in rotational angle order. Recommend ability to cine back and forth (i.e., frames 1 to n, followed by frames n to 1), in addition to the standard forward cine.

6670 **RECON TOMO:** Display all slices in spatial order. Typical display actions can include reorientation to other viewing planes (MPR). Processing (not required by the NM Profile) can include oblique reorientation to cardiac relative views, creation of MIP images, etc. Example: Stress-Rest in a Row Layout display, or a single dataset in an MPR Display.

6675 **GATED TOMO:** Cine all frames (angular views) from one energy window, one (logical) detector, one rotation, one R-R interval, and one Time Slot, or all Time Slots from one energy window, detector, rotation, R-R interval, and Angular View. Some users do not review these images unless data acquisition problems are suspected.

6680 **GATED RECON TOMO:** Cine all frames from one R-R Interval and one Time Slot. Typical processing includes all functions done to RECON TOMO images, plus special cardiac processing such as bull’s-eye plot creation.

Examples of simultaneous cine: three TOMO images (used for quality control of cardiac raw projections); three GATED planar exams (RVGs); or 2 detectors from a dynamic image.

6685 Note that in the U.S., ACR accreditation requires the ability to label displayed images with the patient name, patient age (or date of birth), patient identification number, date of exam, institution name, and some means of identifying the technologist who performed the study.

The Nuclear Medicine Accreditation Committee of the ACR has further required that laterality and orientation information also be provided.

Appendix F: Security Environment Considerations

6690 IHE compliant systems usually process private healthcare information. This is subject to national privacy regulations, and possibly other state and contractual requirements. The IHE profiles do not fully define the security mechanisms necessary to protect this information. The ITI Audit Trail and Node Authentication (ATNA) Profile (ITI TF-1: 9) provides one component of this solution.

IHE assumes that actors will be installed on nodes with the following characteristics:

- 6695
- Each node has a security policy and procedure that applies to its operation. This is assumed to be part of the healthcare enterprise security policy.
 - Any user (human, or application process) external to the node boundaries is submitted to an access control procedure in which the user/application will be authenticated.
 - All required audit trail events are captured and recorded.

6700 The profiles in this framework assume the following environment:

- Physical Security Environment
 - The equipment is assumed to be located in a physically protected and actively monitored area. This is normally the case with modality equipment because of other patient safety, privacy, and operational concerns. Similarly, the HIS systems and various archives are normally protected. Equipment like PACS workstations are sometimes placed in unprotected areas, but it is usually located where hospital staff monitors and limit access. It assumes that the threat of equipment modification is protected against by means of the physical security mechanisms.
 - The network equipment that connects the computers is also assumed to be physically protected against unauthorized connections and unauthorized modifications. In the treatment areas of most hospitals the network equipment is in ceilings, cableways, locked cabinets, and other protected areas. There is usually staff present to monitor that no unauthorized activity is taking place.
 - Local procedures and operations will be in place to ensure that the physical security assumptions are valid for other areas of the hospital, such as administrative offices, that may be at greater risk.
- 6705
- 6710
- 6715

- 6720
 - Remote locations, especially home offices, are not physically protected. Other means will be used to provide equivalent protection. This may include the use of technology such as VPN connections or HTTPS encryption. Use of encryption or VPN is not a complete replacement for physical security but may be part of an overall protection system.
 - The home computer that is used for both personal and professional purposes is difficult to protect. It will be protected from inadvertent modification by malicious software or its use will be prohibited.

- 6725
 - Network Security Environment
 - In addition to the physical security of the network, there will be protection against network access by unsupervised systems. This is typically provided by mechanisms such as firewalls and VPNs.

The threat profile is assumed to be:

- 6730
 - Accidental and inadvertent misuse
 - Individual abuse for personal gain, malice, revenge, or curiosity. The abusers are assumed to have only limited access to the underlying systems and software. They are not expert at the internal structure of the systems.
 - Random untargeted abuse, such as from an Internet hacker.

6735 The threat profile also assumes that the following threats are either not present or otherwise protected.

- Individual abuse by a system administrator, system developer, or other expert.
- Military or hostile government action
- Organized criminal attack

6740 IHE addresses only those security requirements related to IT systems within the scope of IHE healthcare applications. It does not address security requirements for defending against network attacks, virus infection, etc.

6745 IHE does not mandate the use of encryption because the performance impact of current encryption algorithms is excessive. Most hospital networks provide adequate security through physical and procedural mechanisms. The additional performance penalty for encryption is not justified for these networks. The profiles permit the use of encryption so that it can be used as part of an overall security plan.

Appendix G: Patient Information Reconciliation for XDS-I.b (INFORMATIVE)

6750

Patient Information Reconciliation (PIR) workflow within a local domain is well understood and addressed within the IHE PIR Integration Profile. However, within an XDS affinity domain, there is the added complexity of managing patient information within the XDS Document Registry and synchronizing data between the document sources, repository and registry.

6755

The XDS Profile does not address the challenges of PIR. The reason for this is scope management (at the time of writing the initial XDS Profile) as well as a lack of content profiles to stress the PIR issue. It is the intent of the ITI Technical Committee to address the issue of PIR within XDS in due course.

6760

Given that PIR will be addressed within the XDS Profile, this Appendix is considered informative and serves to demonstrate that imaging information content does not introduce any new or imaging information content specific PIR issues.

G.1 Context and Assumptions

G.1.1 XDS Affinity Domain Assumptions

6765

- The Document Registry assumes that all documents have a normalized patient ID pertaining to the XDS Affinity Domain. Therefore:
 - The XDS Affinity Domain must have a Patient Identification Domain in order to realize normalized patient IDs.
 - The XDS Affinity Domain must have a Patient Identity Source Actor
 - To simplify description in this section, the nomenclature for the XDS Affinity Domain will be “XAD”.

6770

- A Document Source is responsible for obtaining the XAD patient ID for registering the document within the registry. The XAD patient ID that is obtained is only used for this purpose and is not used to update any patient ID's within the document. Patient ID's within the document shall remain unchanged by the registration process

6775

- A Document Consumer is expected to query the Document Registry using the XAD patient ID
- The Registry can only accept a document if the document has a valid XAD patient ID
- The Registry must check to see if the XAD patient ID is valid. This can be done in two ways:

6780

- Query the XAD Patient Identity Source to see if the XAD patient ID exists – not supported at this time
- Maintain all XAD patient IDs in the registry irrespective of whether there are documents for that patient i.e., keep in synch with the XAD Patient Identity Source – this is the expected model

- 6785
- The Registry cannot accept a document with an OID that is already registered
 - If a document is submitted that has the OID of a document already registered, the Registry will reject the submission
 - If a document is re-submitted and, thereby, is identical to a document already submitted, the Registry will reject the submission

6790 **G.1.2 Metadata in the Document Registry**

- The XAD patient ID is the only piece of metadata that can be reliably used to query for a patient
 - The Registry maintains supporting patient information such as Name, Sex, DoB, etc. but is NOT obligated to ensure the referential integrity of this data. Therefore:
 - 6795 ○ This information is NOT used for query matching (but is only used for audits and potential verification of Document Consumers)
 - There is no requirement for the XDS Document Registry to verify that the meta-data in the Registry corresponds to the patient information in the document itself
 - The Registry does track the local domain source patient ID, but this is not used for query matching
- 6800

G.1.3 Patient Identity Management in the XDS Registry

- The Registry keeps a list of known XAD patient IDs
 - The Registry associates documents with the patient IDs
 - The Registry receives patient “merge” notifications from the XAD Patient Identity Source
 - The Registry is responsible for updating XAD patient IDs associated with documents
 - The Registry does not update metadata nor document content
 - If the clinical content of a document has changed, the Document Source is responsible for updating the Document Repository and Document Registry
- 6805

6810 **G.1.4 Expected Implementation Models for Patient Identity Management**

In a cross-enterprise scenario, we assume that there are multiple patient identity domains

- Local patient identity domains that support one or more enterprises. These pertain to Document Sources and Document Consumers
 - Affinity Domain patient identity domain
- 6815 Each patient identity domain has a Patient Identity Source. In the case of local domains, this is likely to be an ADT system. For the Affinity Domain, this is yet another patient registry.

A participating enterprise may deploy a Patient Identifier Cross-Referencing (PIX) Manager to cross-map Patient ID in the local domain to Patient ID in XAD domain. In such cases, the PIX Manager will interact with the Affinity Domain Patient Identity Source.

6820 Document sources and consumers are required to obtain a normalized XAD patient ID. The mechanism for achieving this is dependent on the implementation of patient identity feeds and patient identity cross-reference manages within the Affinity Domain. For example, where local domains have PIX Managers, the document sources and consumers obtain the normalized XAD patient ID from the Affinity Domain Patient Identity Source via the PIX Managers. The
6825 document sources and consumers can also obtain the XAD patient ID using other methods such as IHE PDQ or non-IHE approaches.

For the sake of discussion, no assumptions are made on how document sources and consumers interact with the XAD patient identity domain – it could be directly or through a local domain X-ref manager.

6830 Further information on integrating Source and Consumer actors in XDS and XDS-I.b with other IT Infrastructure actors for exchanging patient identifying data across identity domains can be found in ITI TF-1: E.3, E.4, E.5.

G.2 Patient Information Reconciliation (PIR) in an Affinity Domain

6835 PIR workflow within a local domain is well understood and addressed within the IHE PIR Integration Profile. However, within an XDS affinity domain, there is the added complexity of managing patient information within the XDS Registry and synchronizing data between the document sources, repository and registry.

G.2.1 Patient Merge within XAD Patient Identity Domain

- XAD patient identity domain merges two patients
- 6840 • Document sources are unaware of the merge transaction within XAD patient identity domain

In this situation:

- XDS Registry receives a merge notification from the XAD patient identity source and applies merge logic to the registry
- 6845 • Document consumers have continued access to documents pertaining to the patient since consumers are expected to obtain the XAD patient ID for the patient at the time of querying the Registry
- Document sources are unaware of the merge transaction that occurred in the XDS registry and do not need to be made aware of this merge. The reasons for this are:
 - 6850 ○ Consumers have continued access to the document

- The document source must query for the XAD patient ID before attempting to interact with the repository and registry. As such, the document source will have an updated XAD patient ID at the time of interacting with the registry.
- When a document source wishes to submit a change to the document:
- 6855 ○ The document source must query for the XAD patient ID before registering the new document
- The document source must register the new document with a request to deprecate the old document. From the document source's perspective, the old document is still associated with the original XAD patient ID. By virtue of obtaining a new XAD patient ID for the patient, the document source must assume that a patient merge has
- 6860 taken place and use the new XAD patient ID to deprecate the old document

The process flow is described in more detail as follows:

Scenario:

- 6865 • Key identifier for a patient within the XAD patient identity domain changes, such as health number
- The XAD patient identity source merges two patients

Process Steps:

1. The XAD patient identity source sends a “merge” notification to the XDS Registry
 2. XDS Registry applies merge logic to the patients within the merge notification
- 6870 • The metadata in the registry will be accurate with the exception of the source patient ID

G.2.2 Local Domain Patient Update - XAD Domain Patient ID does not change

- 6875 • Demographics for the patient change
- Local domain patient ID does NOT change
- XAD patient ID does NOT change

In this scenario:

- 6880 • XDS Registry does nothing since the XAD patient ID has not changed
- If a document source changes the patient demographics content of a document and a new document is created then this document should be registered with the XDS repository/registry as a replacement to the old document

The process flow is described in more detail as follows:

Scenario:

- 6885
- Patient first name is corrected from “Jamie” to “James” in the local domain patient identity source

Process Steps:

- 6890
1. Update information flows from the local domain patient identity source (i.e., ADT) to the document source: image manager/archive.
 - Document source updates its database to correct demographics
 - Either: Document source does not change the document
 - The Document Source does not update the repository/registry. In this scenario, the patient demographics: Name, DoB, Sex, etc.; in the Document Source do not match those in the XDS Registry. This is acceptable in the XDS Profile.
 - Or: Document source changes the document
- 6895
- The Document Source updates the repository/registry with an addendum.
2. The Registry takes no action as the XAD patient ID has not changed

G.2.3 Local Domain Patient Update - XAD Domain Patient Merge

- 6900
- Demographics for the patient change
 - Local domain patient ID does NOT change
 - XAD patient ID does change and triggers a merge within XAD domain
 - Document sources are unaware of the merge transaction within XAD patient identity domain

6905 In this scenario:

- See Section G.2.1 Patient Merge within XAD Patient Identity Domain

The process flow is described in more detail as follows:

Scenario:

- 6910
- Patient last name is corrected from “Alfonsp” to “Alfonso” within local domain patient identity source
 - XAD domain patient identity source merges “Alfonsp: XAD-Pp” into “Alfonso: XAD-Pa” – patient “Alfonso” was already registered within the XAD domain with patient ID XAD-Pa

6915 **Process Steps:**

- See Section G.2.1 Patient Merge within XAD Patient Identity Domain

G.2.4 Local Domain Patient Merge – XAD Domain Patient ID does not change

- Demographics for the patient changes
- 6920
- Local domain patient identity source merges patient A with patient B
 - XAD patient ID for patient A and patient B are the same

In this scenario:

- XDS Registry does nothing since the XAD patient ID for patient A and patient B is the same
- 6925
- Document sources apply merge logic to the documents within their database i.e., documents are now associated with a new local domain patient ID
 - Document sources must now query XAD patient identity source to obtain the XAD patient ID for the merged patient
 - The XAD patient ID is the same as already associated with the document:
- 6930
- If the document source does not change the document content, the document source does not need to interact with XDS Repository/Registry – status quo
 - If the document source changes the patient demographics content of a document and a new document is created, then this document should be registered with the XDS repository/registry as a replacement to the existing document.

6935 The process flow is described in more detail as follows:

Scenario:

- Patient last name is corrected from “Smythe” to “Smyth”
 - ADT already has an entry for “Smyth”
 - “Smythe” with local domain patient ID D-123 is merged with Smyth with local domain patient ID D-456
- 6940
- XAD Patient Identity Source already recognized “Smythe: D-123” and “Smyth: D-456” as the same patient and, therefore, assigned each with the same XAD patient ID: XAD-Px

Process Steps:

- 6945
1. Update information flows from the local domain patient identity source (i.e., ADT) to the document source: image manager/archive.
 - Document source applies merge logic to the database: documents for the merged patient are associated with the new patient ID

- 6950 2. Document source queries the XAD patient identity domain to determine whether the XAD patient ID has changed for the merged documents. In this case the XAD patient ID does not change
3. Document source updates the demographics of the document
- Either: Document source makes no changes to the document – demographics are in the database
- 6955 ○ The Document Source need not update the repository/registry. In this scenario, the patient demographics in the Document Source do not match those in the XDS Registry. This is acceptable in the XDS framework
- Or: Document source changes the document
 - The Document Source updates the repository/registry with an addendum.
- 6960 4. The Registry takes no action as the XAD patient ID has not changed

G.2.5 Local Domain Patient Merge – XAD Domain Patient Merge

- Demographics for the patient changes
 - Local domain patient identity source merges patient A with patient B
 - XAD patient IDs for patient A and patient B are different
- 6965 • Patient A is merged with patient B in the XAD domain patient identity source

There are three situations that can occur:

1. XDS Registry merge prior to Document Source merge
- 6970 • XDS Registry receives a merge notification from the XAD patient identity source and applies merge logic to the registry
- Document sources are unaware of the merge transaction that occurred in the XDS registry and do not need to know about this transaction (see Section G.2.1)
 - Document consumers have continued access to documents pertaining to the patient since consumers are expected to obtain the XAD patient ID for the patient at the time of querying the Registry
- 6975 • Document sources apply merge logic to the documents within their database i.e., documents are now associated with a new local domain patient ID
- Document sources must now query XAD patient identity source to obtain the XAD patient ID for the merged patient
- 6980 • The XAD patient ID for the documents has changed:

- The document source changes the XAD patient ID associated with the documents – it can assume that the Registry has made this change as well
 - If the document source does not change the document content, the document source does not need to interact with XDS Repository/Registry – status quo
 - 6985 • If the document source changes the patient demographics content of a document and a new document is created then this document should be registered with the XDS repository/registry – the existing document is deprecated.
2. Document Source merge prior to XDS Registry merge
- 6990 • Document sources apply merge logic to the documents within their database i.e., documents are now associated with a new local domain patient ID
 - Document sources must now query XAD patient identity source to obtain the XAD patient ID for the merged patient
 - The XAD patient ID is the same as already associated with the document:
 - 6995 ○ If the document source does not change the document content, the document source does not need to interact with XDS Repository/Registry – status quo
 - If the document source changes the patient demographics content of a document and a new document is created, then this document should be registered with the XDS repository/registry as a replacement to the old document
 - 7000 • XDS Registry receives a merge notification from the XAD patient identity source and applies merge logic to the registry
 - Document sources are unaware of the merge transaction that occurred in the XDS registry and do not need to know about this transaction
 - Document consumers have continued access to documents pertaining to the patient since consumers are expected to obtain the XAD patient ID for the patient at the time of querying the Registry
 - 7005
3. Document Source merge at same time as XDS Registry merge
- Document sources apply merge logic to the documents within their database i.e., documents are now associated with a new local domain patient ID
 - 7010 • Document sources must now query XAD patient identity source to obtain the XAD patient ID for the merged patient
 - The XAD patient ID is the same as already associated with the document
 - XDS Registry receives a merge notification from the XAD patient identity source and applies merge logic to the registry

- 7015
- Document source chooses to change the patient demographics content of a document and a new document is created. This document is registered with the XDS repository/registry:

The XAD patient ID for this document has now been merged in the XDS Registry and, therefore, is no longer valid

- 7020
- The Registry will reject the document registration transaction as the XAD patient ID used in the transaction is no longer valid.

Document sources must now query XAD patient identity source to obtain the XAD patient ID for the merged patient and re-register the document with the XDS repository/registry

7025 ***Scenario:***

- Patient last name is corrected from “Smythe” to “Smyth”
- ADT already has an entry for “Smyth”
- Smythe: patient ID D-123 is merged with Smyth: patient ID D-456
- XAD Patient Identity Source has separate entries for both “Smythe: XAD-Pc” and “Smyth: XAD-Pf”. As such, it merges these two patients in to “Smyth: XAD-Pf”.

7030

Process Steps:

The process flow is a combination of the previous scenario process flows and, thereby, not repeated here.

7035 **Appendix H: Security considerations for XDS-I.b (informative)**

This IHE profile does not specify all the details of the security environment for exchanging radiology information. The IHE includes several security profiles that apply to the XDS/ XDS-I.b use. The use of these security profiles in the first trial implementation for XDS-I.b will likely be optional. The security profiles make assumptions about the overall security environment and are configurable to adapt to different security requirements.

7040

Figure H-1 shows typical transactions for XDS-I.b. Each transaction goes through security and privacy controls. This figure illustrates use of firewall access points and TLS controls for all XDS-I.b participants, including the Imaging Document Source. The firewalls may have simple easy to implement rules or more complex rules depending upon local policies. The flows shown in Figure H-1 are described in more detail below:

7045

Flow #1, The Store Images, etc. transactions:

a) Internal firewall rules I:

- Simple rules: “outgoing HTTP is OK”

- Complex rules: examine source IP, destination IP, HTTP headers to decide whether to permit the connection.

7050

b) TLS within each actor:

- IM/IA: Is this really the authorized Image Document Source that was requested?

- Repository: Is this really an authorized IM/IA?

c) Once the TLS connection is established there is further processing, generation of audit records, etc.

7055

Flow #2, The Provide and Register Imaging Document Set transaction:

a) does not cross a firewall

b, c) TLS, authorization, auditing as above.

7060

Flow #3, The Register transaction

a) External firewall rules II:

- Simple: Outgoing HTTP is OK

- Complex: examine source IP, destination IP, HTTP headers to decide whether to permit the connection.

7065

b, c) TLS, authorization, auditing as above.

Flow #4, Query Documents transaction:

a) External firewall access rules II:

- 7070
- Simple: Incoming HTTP to the DMZ is OK
 - Complex: very tricky given many different uses for HTTP incoming by different web applications.

b, c) TLS, authorization, auditing as above.

7075 **Flow #5, Retrieve Images, etc. transactions:**

a) External firewall access rules III:

- 7080
- Simple: Incoming DICOM is only permitted from authorized affinity domain IP blocks.
 - Complex: Examine the DICOM retrieve connection initiator and the targeting acceptor IP addresses, and permit only connections between a priori authorized pairs of initiator and acceptor.

b, c) TLS, authorization, auditing as above.

7085 This example shows access for both HTTP and DICOM traffic. It is easier to get multi-layer protection for the DICOM traffic because it is easily differentiated from the many diverse uses of HTTP for web applications and services. Then the TLS security, actor authorization rules, and auditing are applied to all traffic regardless of type.

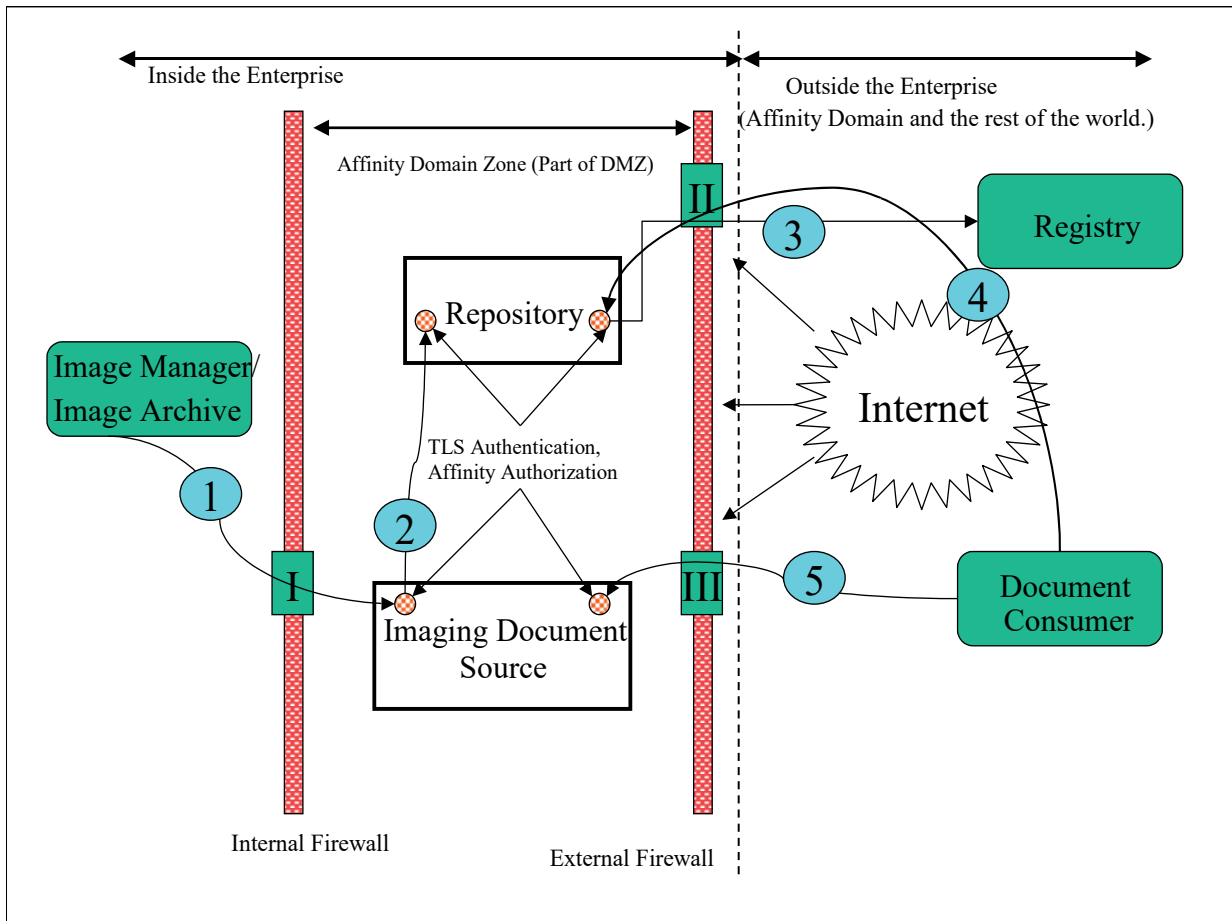

Figure H-1: Security Environment

7090 IHE assumes that there will be some form of external control point. This usually involves technologies like VPNs, firewalls, routers, etc. IHE does not specify what is necessary here, and the IHE profiles will operate and provide a good level of security even when the external control point is missing.

The purpose of having an external control point is:

- 7095
- To control the low-level network access between the Internet and the Imaging Document Source and Document Repository. The precision of this control is up to the sites involved. One common configuration is to merely restrict the list of IP Ports that are permitted access. This simplifies the security requirements on the server.
 - Log and monitor all traffic for indications of hostile or abusive activity. This is usually a combination of logging and intrusion detection (IDS) activity that is oriented towards the overall IT organization requirements.
- 7100

This kind of protection is useful and complements the encryption and access controls defined as part of IHE's Audit Trail and Node Authentication (ATNA) Profile and its Radiology Option.

7105 The internal network is probably divided into two or more zones that are isolated by internal control points. These internal control points are similar to the external control point, but usually are much more permissive in terms of the traffic that they allow. They exist both to detect problems and to provide a means of rapidly isolating portions of the network in the event of a security breach.

7110 The Imaging Document Source is assumed to be located in the zone labeled the “Affinity Domain Zone”. This might also be part of a general DMZ (De-Militarized Zone) for the organization or it might be a special zone reserved exclusively for Affinity Domain activities. There are cost and functionality tradeoffs involved in making that decision and the IHE profiles support both approaches.

7115 IHE will specify the minimum-security requirements for the Imaging Document Source. It will be expected to comply with the IHE ITI ATNA (Audit Trail and Node Authentication) Integration Profile. There may be multiple Imaging Document Sources in the Affinity Domain Zone and they will all be expected to comply with the ATNA Profile. This profile mandates:

- All connections that might transfer protected health information (PHI) must utilize TLS configured to:
 - Authenticate both machines involved
 - 7120 • Ensure that all traffic is encrypted, either directly by TLS or by means of equivalent protection such as VPN.
 - Enforce access control to the system
 - Provide a detailed security audit trail for all PHI related activity and information transfers

7125 The TLS protocol is also widely known as HTTPS. The ATNA Profile mandates this protection for any DICOM, HL7, HTTP or other protocols.

There may be special auditing requirements for an XDS-I.b actor. For example, in the US there are HIPAA requirements for disclosure logs. Only the sites themselves can determine what belongs in a disclosure log. The ATNA logs were not directly intended for this purpose.

7130 The Imaging Document Source may be a system that is complete with its own image archive, or it may be a proxy machine that relays information to another machine, perhaps located in a private zone. This is considered an internal design issue by IHE. The XDS-I.b Profile specifies that the Imaging Document Source must support the XDS-I.b transactions, and does not specify the internal design.

7135 There are several important design considerations for securing XDS-I.b networks that must be made by the affinity domain and its members. These are:

1. What kind of external control points are used? IHE recommends that they be present, but does not profile them.
 2. How to subdivide the enterprise network and whether to establish a dedicated Affinity Domain Zone. There is an advantage to creating an Affinity Domain Zone with just a few servers located in it:
- 7140

- a. The log analysis is easier
 - b. The certificate and TLS management for node authentication is easier
 - c. The preparation of disclosure logs and the equivalent is easier.
 - d. The internal control point reduces the risks from a breach of the Affinity Domain Zone.
- 7145
3. Whether User Authentication is needed. IHE provides both the ITI Enterprise User Authentication (EUA) and the Cross-Enterprise User Assertion (XUA) Profiles. Use of user authentication permits additional information to be captured in the audit logs (e.g., the identity of the user) and permits additional access control in some situations. The issues that the affinity domain and sites must address are:
- 7150
- a. What to do about automated processes, such as pre-fetch and email. These can be identified using node authentication via TLS as specified in ATNA, by using simple identity assertions.
 - b. How to handle delegation. Often it is clerks, nurses, etc. that are actually operating the computer to obtain the records for a patient, and it is someone else that will actually be examining the records. So, the user authentication might not provide any further useful information.
- 7155

The IHE profiles do not determine these choices. Some reasonable selections include:

- 1. Not using user authentication. The ATNA ensures that the enterprise and the machine are authenticated. These machines are already authenticated and trusted to protect PHI information. It may be impractical to track and coordinate the personnel activities across all the different organizations.
 - 2. Though not specifically designed for this purpose, it is also possible that the XDS-I.b Profile is being used internally within a centrally controlled large organization, where the Kerberos based identity management of EUA is available. EUA can be used in such an intra-enterprise environment. EUA supports simple identity assertions. These are based on trusting the authenticated node to provide the correct identity of its user.
 - 3. The use of XUA is optional. Where a human user is involved, XUA can be employed for cross-enterprise user identity assertion. If only machines are involved, the node authentication provided by ATNA should be sufficient. The use of XUA requires that the affinity domain establish the authentication policies, procedures, and have a supporting infrastructure of servers, etc. (This infrastructure may be provided by the local government or might need to be provided by the affinity domain.)
- 7160
- 7165
- 7170
- 7175

Note: In order to use the XUA Profile, the underlying application protocol must be able to carry a user identity assertion in its payload. While such a mechanism has been established in HL7 and HTTP/S, the mechanism to provide this for DICOM messages is still under development. Thus, XUA Profile cannot (yet) be employed when retrieving DICOM SOP Instances referenced in the manifest document.

7180 The affinity domain and individual site policies will determine the choices made. There are IHE profiles defined to address these alternatives.

Appendix I: Appendix I – Deployment of Dose Registries

7185 The Radiation Exposure Management Profile is intended to facilitate Dose Registry projects. Participating sites that have implemented the REM Profile can be depended on to provide data with known contents in a known format and will all support a common transport mechanism. See the Submit Dose Information transaction for details (RAD TF-3: 4.63).

7190 This appendix includes discussions of logistical issues related to the deployment of dose registries. This is not part of the normative text of the REM Profile, but the discussions here may be helpful when deploying and using the REM Profile.

I.1 Dose Registry Deployment Issues

I.1.1 Code Set Management

7195 Although the REM Profile does manage to provide consistent dose data, for a Dose Registry to analyze dose objects and prepare summary statistics for a specific exam type, anatomy or pathology/indication, it will need to select/group dose objects based on exam type, anatomy or pathology/indication.

If the different sites submitting data used consistent code sets for coding such details, this might be easy, but unfortunately, for technical and organizational reasons, such code set consistency is unlikely. Due to similar issues, consistency *within* an organization may even be challenging.

7200 Dose Registries should be prepared to deal with such non-uniformity. For example, they may need to manage lookup tables to map codes from each submitting organization to a set of standard codes or categories. This may involve reverse engineering the codes from Code Description fields, when available, or it may involve requesting code sets from participating sites.

7205 Dose Registries should also be prepared for a lack of detail e.g., there may be a procedure code for “stent placement” but no indication if it was one stent, three stents, or more.

I.1.2 Configuration of Secure FTP (Submit Dose Information [RAD-63])

The REM Profile requires Dose Information Reporters support the Submit Dose Information Transaction for the purpose of submitting dose data to Dose Registries.

7210 The Submit Dose Information Transaction specifies the use of FTP over TLS.

When setting up the FTP server the dose registry project should consider useful features such as:

- Setting up individual login accounts for each participating site
- Directing files from clients into specific folders based on their login account id
- Preventing clients from looking at other folders

7215 **I.1.3 Alternative Transport Mechanisms**

The DICOM STOW-RS Transport mechanism defined in the Submit Dose Transaction is intended to provide a baseline transport mechanism. It is not intended to prohibit Dose Registry projects from using other transport mechanisms, as long as they also support the baseline mechanism.

7220 Some alternative transport mechanisms to consider include sending the objects via:

- CD using the IHE Portable Data for Imaging (PDI) Profile
- Secure FTP (which was defined in the original REM Profile but has been removed)
- Email using the DICOM Email Media Profile and SMTP (XDM)
- Network using DICOM C-STORE over TLS or a VPN to a DICOM Storage SCP

7225 • Network using the IHE Cross-Domain Document Sharing for Imaging (XDS-I) Profile

- Note the need to establish an Affinity Domain covering all contributing sites and to fill in the XDS metadata which may be complicated by de-identification.
- Note also the need to provide an Imaging Document Source at the provider end, since XDS-I does not “push” the dose objects themselves to the recipient, but rather registers their availability, requiring them to then be “pulled”.

7230 • Network using the IHE Cross-Domain Document Reliable Interchange for Imaging (XDR-I) Profile

- This might be attractive if XDR-I features such as multi-file bundles, and “replacing” documents would be useful.

7235 • Note again the need to fill in the XDS metadata.

I.1.4 Encapsulated Dose Registry Submission

Another approach to addressing submission issues and facilitating site is for the organization that is setting up a dose registry project to develop and distribute a client application to each participating site.

7240 The client includes an implementation of a Dose Information Consumer or Dose Information Reporter which allows it to gather dose objects from the Image Archive. The client would also incorporate a proprietary upload mechanism to get the dose objects up to the dose registry.

Note that while this approach has the potential to simplify some technical issues, it introduces a number of security issues. Some sites may need to review and approve such a client before allowing foreign software on their network, particularly if it is capable of sending patient data outside the organization.

7245

Imagine:

- the XYZ Dose Registry Client implements the Dose Information Consumer to get dose objects, and some email or web services protocol to send them to the Dose Registry

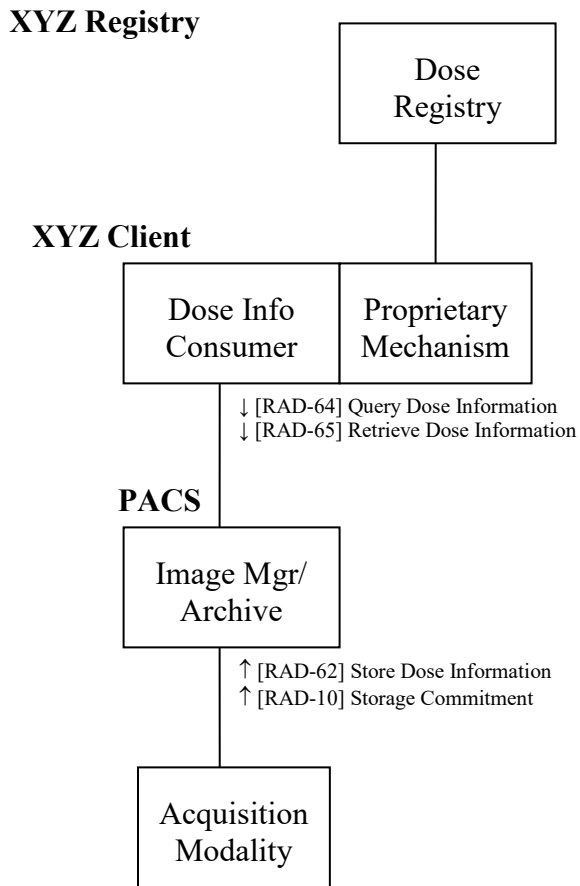

7250

I.2 Real-World Projects

A number of organizations have established or are in the process of establishing Dose Registry projects.

7255 **Project: ACR Registry - USA**

ACR is forming a national Dose Index Registry (DIR). The initial pilot program will compare CT dose indices across 10-12 facilities to identify areas that may require changes to CT dose protocols. At the completion of the pilot program, the DIR will launch nationwide.

7260 Their ultimate goal is minimizing dose to the patient population and they are interested in Use Cases including: Population Dose and Dose Indicators, Dose Reference Levels and Benchmarking. They are specifically not interested in the Patient Dose History Use Case as they have no plans to become a national personal dose record.

Website: nrdr.acr.org

Project: French Ministry of Health Registry

7265 French regulations mandate the submission of Dose Reference Level data to a federal dose registry managed by the Institut de Radioprotection et de Sûreté Nucléaire / Institute for Radiation Protection and Nuclear Safety (IRSN).

7270 Every year each specialist must submit dosimetric information (at least 20 patients) for each of at least two examination types (generally the most frequent and most irradiating examination types).

The ministry is interested in Use Cases including: Population Dose and Dose Indicators, and Dose Reference Levels. Data collection spans Radiography, Fluoroscopy, Mammography, Computed Tomography and Nuclear Medicine. The data is further broken down by patient age category, and body part.

7275 Website: www.irsn.org/en

I.3 Dose Monitoring Regulations

Several groups interested in regulatory issues (IEC, FDA, AAPM, etc.) drove original definition of the DICOM Dose SR objects.

7280 The following sections contain some contributed summaries of different regulatory initiatives. These are only intended to provide a sense of the type of activities. Readers should refer to the regulations themselves for accurate information.

European Regulatory

7285 European regulation is based on European Directive Euratom 1997/43/EC. The application of the directive is mandatory in all EU countries (27 today) since 2000. All European national regulations have to be compatible with the directive. Different countries have varied in their reactions/actions to Euratom.

Euratom specifies a follow up for each patient and statistical analysis at the population level.

Euratom: http://ec.europa.eu/energy/nuclear/radioprotection/legislation_en.htm

Diagnostic Reference Levels (DRLs) in Europe:

7290 http://www.eu-alara.net/index.php?option=com_content&task=view&id=156&Itemid=53

French Regulatory

Today two regulations specify the dosimetric information that a user of ionising radiation must provide in France.

- 7295 • One text, published in March 2004, concerns Dose Reference Levels (DRL) (Arrêté du 12 février 2004 relatif aux niveaux de référence diagnostiques en radiologie et en médecine nucléaire – Journal Officiel de la République Française du 16 mars 2004).
- Another text, published in September 2006, concerns dosimetric information that must be present in the medical record of the diagnostic examination (Arrêté du 22 septembre 2006

7300 relatif aux informations dosimétriques devant figurer dans un compte rendu d'acte utilisant les rayonnements ionisants - Journal Officiel de la République Française du 29 septembre 2006).

For each medical procedure using ionising radiation, the medical record must include information allowing estimation of the dose received by the patient.

German & Dutch Regulatory

7305 In Germany and the Netherlands, dose information is not conveyed above the Hospital level. Dose information is required and must be auditable.

Germany is working on additions to the DICOM Basic Diagnostic Imaging Report to include Radiation Regulation related details such as:

- Pregnancy Status
- 7310 • Indications for Procedure
- Physician Responsible for Indication
- Performing Person (who administered)
- Radioactive Substance Administered
- Radiation Exposure (text description of "the exposure")
- 7315 • Performing Person's Organization Name

Spanish Regulatory

In Spain, dose information is not conveyed above the Hospital level.

7320 Dose information is required in order to audit the use of diagnostic equipment (comparing with Dose Reference Levels) and must be auditable by the responsible health authority. Also the responsible health authority and the Nuclear Security Council will guarantee that the distribution of the estimations of resulting individual doses is determined, for the population and the significant groups of reference of the population, whose results will be sent to the Ministry of Health and Consumption.

7325 **GLOSSARY**

Terms Specific to this Document

Accession Number: A user-friendly identifier created by the Departmental System, which identifies an instance of a filler order or imaging service request. It may group one or more requested procedures.

7330 **Actor:** An entity within a use case diagram that can perform an action within a use case diagram. Possible actions are creation or consumption of a message.

Conventional 2D mammography: Refers to mammography images that have been acquired using FFDM.

7335 **Dose Object:** A persistent DICOM object (See DICOM PS3.3: A.35.8 X-Ray Radiation Dose SR IOD) for recording details related to Irradiation Events. DICOM has defined Dose Objects for CT and Projection X-ray procedures.

Dose Registry: A system that collects dose information from multiple sites, generally to perform analysis of Population Dose and Dose Indicators.

DVD: A trademark of the DVD Forum that is not an abbreviation

7340 **Evidence Documents:** Evidence Documents represent the uninterpreted information that is primarily managed and used inside the imaging department, although distribution outside the imaging department is not precluded. Evidence documents are non-image information and include things such as measurements, CAD results, procedure logs, etc. and are to be encoded as DICOM SR documents.

7345 **Evidence Objects:** All objects generated as a result of performing procedure steps on systems in an imaging department. These objects are used by the reading physician in the process of creating a diagnostic report and are managed inside the imaging Department. Examples of evidence objects include: Images, Presentation States, Key Image Notes and Evidence Documents.

7350 **Expected Actions:** Actions which should occur as the result of a trigger event

Foreign Key (FK): A database key that is used as a reference to relate one entity to another entity. It may be a unique value, or used in conjunction with another Foreign Key to create a unique value.

7355 **Hardcopy Import:** The process of importing non-digital data into the Enterprise as DICOM Objects. The original data may be Films or Documents that are scanned and stored as DICOM Objects.

Images Available: A transaction or transactions used to determine that images have been stored in an image archive and may be retrieved.

Interaction Diagram: A diagram which depicts data flow and sequencing of events

7360 **Interchange Media:** A piece of data-bearing physical media, such as a CD or DVD. The term, which is used in the DICOM standard, is synonymous with “portable media” or “transfer media”.

7365 **Irradiation Event:** An irradiation event is one continuous occurrence of irradiation being applied to a patient. A pulsed fluoro X-Ray acquisition, or a multi-slice helical CT scan are examples of single events; while a CT scanogram and the helical scan, or two different presses of the fluoro pedal, or simultaneous irradiation from two X-ray tubes are examples of separate events. See RAD TF-3: 4.62.4.1.1 in Store Dose Information for a more detailed description

Pre-fetch: The activity of fetching images or other information objects from previously completed procedures to near-term storage for review of those data.

7370 **Process Flow Diagram:** A graphical illustration of the flow of processes and interactions among the actors involved in a particular example

Role: The actions of an actor in a use case.

Scope: A brief description of the transaction.

Slab: A thick slice tomosynthesis reconstruction (e.g., greater than 1mm).

7375 **Trigger Event:** An event such as the reception of a message or completion of a process, which causes another action to occur.

Use Case: A graphical depiction of the actors and operation of a system.

W3C: A trademark of the World Wide Web Consortium that is not an abbreviation

Web-Viewable: Browsable using a web browser (e.g., XHTML files and JPEG images)

7380 **XDS Imaging Document:** An XDS Imaging Document is the smallest unit of imaging related information that may be provided to a Document Repository and registered in a Document Registry. An XDS Imaging Document may contain a manifest of images (e.g., DICOM Key Object Selection document) or a radiology report provided either as a PDF document or as structured and vocabulary coded clinical information (e.g., CDA Release 2).

7385 **DICOM Terms**

Basic Color Print Management Meta SOP Class: See DICOM PS3.4

Basic Grayscale Print Management Meta SOP Class: See DICOM PS3.4

Basic Text SR Storage SOP Class: See DICOM Supplement 23

DICOM Model of the Real World: See DICOM PS3.3

7390 **Enhanced SR Storage SOP Class:** See DICOM Supplement 23

Grayscale Softcopy Presentation State Storage SOP Class: See DICOM PS3.4

Grayscale Standard Display Function: DICOM PS3.14

Imaging Service Request: See DICOM PS .3

Modality: See DICOM PS3.3

7395 **Modality Worklist SOP Class:** See DICOM PS3.4

- Modality Performed Procedure Step:** See DICOM PS3.3
- Modality Performed Procedure Step Information Module:** See DICOM PS3.3
- Modality Performed Procedure Step Relationship Module:** See DICOM PS3.3
- Modality Performed Procedure Step SOP Class:** See DICOM PS3.4
- 7400 **Patient:** See DICOM PS3.3
- Patient Identification Module:** See DICOM PS3.3
- Print Presentation LUT SOP Class:** See DICOM PS3.4
- Procedure Plan:** See DICOM PS3.3
- Procedure Type:** See DICOM PS3.3
- 7405 **Protocol Code:** See DICOM PS3.3
- Requested Procedure:** See DICOM PS3.3
- Requested Procedure Module:** See DICOM PS3.3
- Requested Procedure ID:** See DICOM PS3.3
- Results Information Object Definition:** See DICOM PS3.3
- 7410 **Scheduled Procedure Step:** See DICOM PS3.3
- Scheduled Procedure Step Module:** See DICOM PS3.3
- Storage Commitment SOP Class:** See DICOM PS3.4
- Stored Print SOP Class:** See DICOM PS3.4
- Structured Reporting Information Object Definitions:** See DICOM PS3.3
- 7415 **Structured Reporting SOP Classes:** See DICOM PS3.4
- Structured Reporting Templates:** See DICOM PS3.16
- Unique Identifier (UID):** See DICOM PS3.5

HL7 Terms

- 7420 **ADT:** See HL7 version 2.3.1
- Battery:** See HL7 version 2.3.1
- Filler:** See HL7 version 2.3.1
- Observation:** See HL7 version 2.3.1
- Placer:** See HL7 version 2.3.1
- 7425 **Universal Service ID:** See HL7 version 2.3.1

Acronyms and Abbreviations

- ACR:** American College of Radiology
- CAD:** Computer Aided Detection
- 7430 **CD:** Compact Disk
- DAP:** Dose Area Product
- DBT:** Digital Breast Tomosynthesis
- DLP:** Dose Length Product
- FDA:** Food and Drug Administration (USA)
- 7435 **FFDM:** Full Field Digital Mammography
- FSC:** File-Set Creator
- FSR:** File-Set Reader
- GSPS:** Grayscale Softcopy Presentation State
- HIMSS:** Healthcare Information and Management Systems Society
- 7440 **HIS:** Hospital Information System
- HTML:** Hyper Text Markup Language
- ICRU:** International Commission on Radiological Units
- IEC:** International Electrotechnical Commission
- IHE:** Integrating the Healthcare Enterprise
- 7445 **IOD:** Information Object Definitions
- IT:** Information Technology
- JPEG:** Joint Photographic Experts Group
- LUT:** Look Up Table
- MPI:** Master Patient Index
- 7450 **MPPS:** Modality Performed Procedure Step
- MQSA:** Mammography Quality Standards Act of 1992
- MWL:** Modality Worklist
- NEMA:** National Electrical Manufacturers Association
- PACS:** Picture Archive and Communication System
- 7455 **PHI:** Protected Healthcare Information
- PPS:** Performed Procedure Step
- PSD:** Peak Skin Dose

QA: Quality Assurance

RIS: Radiology Information System

7460 **RSNA:** Radiological Society of North America

SCU: Service Class User

SCP: Service Class Provider

SR: Structured Report

UID: Unique Identifier

7465 **USB:** Universal Serial Bus

XHTML: eXtensible Hypertext Markup Language

References

- [1] American College of Radiology White Paper on Radiation Dose in Medicine, E. Stephen Amis, et al, Journal of American College of Radiology, 2007, Vol. 4, pp. 272-284
- 7470 [2] Quality Improvement Guidelines for Recording Patient Radiation Dose in the Medical Record, Donald Miller, Stephen Balter, et al, Journal of Vascular Interventional Radiology, 2004, Vol. 15, pp. 423-429
- [3] ICRU. Report 74: Patient Dosimetry for X-Rays Used in Medical Imaging. JICRU 5; 2005.
- 7475 [4] IEC. IEC 60601. (2000). Medical electrical equipment - Part 2-43: Particular requirements for the safety of X-ray equipment for interventional procedures. Geneva; 2000.
- [5] IEC. PAS 61910-1 Radiation Dose Documentation Part 1: Equipment for radiography and radioscopy. Geneva; 2007.
- 7480 [6] FDA. Federal performance standard for diagnostic x-ray systems and their major components-- FDA. Final rule. Fed Regist 70: 33998 - 34042; 2005.
- [7] Capturing Patient Doses from Fluoroscopically Based Diagnostic and Interventional Systems, Stephen Balter, NCRP Annual Meeting-07; 2008