

GMSIH, HPRIM and JAHIS

Integrating the Healthcare Enterprise



**Laboratory
Technical Framework**

**Volume 1
(LTF-1)
Integration Profiles**

Revision 1.1 – Final Text
July 8, 2004

Copyright © 2003: GMSIH, HPRIM, IHE-J, JAHIS

Contents

0	1	Introduction	2
	1.1	Overview of IHE	2
	1.2	Overview of Laboratory Technical Framework	2
	1.3	Audience	3
	1.4	Relationship to Real-world architectures	3
	1.5	Conventions	3
	1.6	Comments	4
	1.7	Copyright permissions	4
	1.8	IHE Technical Framework Development and Maintenance Process	4
	2	Integration profiles	5
0	2.1	Scope	5
	2.2	Laboratory specialties	6
	2.3	Integration Profiles overview	6
	2.4	Actors in Laboratory Technical Framework	7
	3	Laboratory Scheduled Workflow	8
	3.1	Use cases	8
	3.1.1	Externally placed order with identified specimens.....	8
	3.1.2	Externally placed order with specimens unidentified or to be collected by the laboratory...	9
	3.1.3	Filler order with specimens identified by third party or collected by the laboratory	9
	3.2	Laboratory specialties/Use cases	11
0	3.3	Actors/Transactions	12
	3.4	Data model	14
	3.5	Process Flow	17
	3.5.1	Laboratory Scheduled Workflow with the first two use cases: placer ordering	17
	3.5.2	Laboratory Scheduled Workflow with the third use case: filler ordering	18
	3.5.3	Patient update flow	19
	3.5.3.1	Patient information update before creation of an order	19
	3.5.3.2	Patient information update after creation of an order	20
	3.5.3.3	Patient information update after fulfillment of the order.....	21
	3.5.4	Order/result update, status change, cancellation, exceptions management	22
0	4	Glossary	23
	5	Outstanding issues	24
	5.1	Current issues	24
	5.2	Reminder for future cycles	24

1 Introduction

1.1 Overview of IHE

0 Integrating the Healthcare Enterprise (IHE) is an initiative designed to stimulate the integration of the information systems that support modern healthcare institutions. Its fundamental objective is to ensure that in the care of patients all required information for medical decisions is both correct and available to healthcare professionals. The IHE initiative is both a process and a forum for encouraging integration efforts. It defines a technical framework for the implementation of established messaging standards to achieve specific clinical goals. It includes a rigorous testing process for the implementation of this framework, organizes educational sessions, exhibits at major meetings of medical professionals to demonstrate the benefits of this framework and encourage its adoption by industry and users.

The approach employed in the IHE initiative is not to define new integration standards, but rather to support the use of existing standards in an integrated manner, defining configuration choices when necessary. When clarifications or extensions to existing standards are necessary, IHE refers recommendations to the relevant standards bodies.

1.2 Overview of Laboratory Technical Framework

0 The 2003 – 2004 cycle of IHE extends the initiative to clinical laboratories, their information and automation systems and equipment. This document, the Laboratory Technical Framework defines the new profiles, actors and transactions that have evolved with this extension. It also chooses the appropriate messages of established standards to cover this new domain, and defines their implementation.

The Laboratory Technical Framework is organized in two volumes:

Volume 1 provides a high-level view of the domain, identifying the IHE Actors (i.e. functional components, application roles), and showing the transactions between them, organized into functional units called integration profiles that highlight their capacity to address specific clinical needs.

Volume 2 provides a detailed technical description of each transaction and of its messages.

0 This document is updated annually, following a period of public review, and maintained regularly through the identification and correction of errata. The current version, Rev. 1.0 for Trial Implementation, specifies the IHE transactions defined and implemented as of November 2003. The latest version of the document is available via the Internet at www.gmsih.fr and www.rsna.org

It has been produced with the help of the following organizations:

GMSIH (Groupement pour la Modernisation du Système d'Information Hospitalier)

HL7 and its affiliate organizations

H.PR.IM (Association « Harmoniser et Promouvoir les Informatiques Médicales »)

IHE-J (IHE Japan)

JAHIS (Japanese Association of Healthcare Information Systems Industry)

RSNA (Radiological Society of North America)

0 SFIL (Société Française d'Informatique de Laboratoire)

Main contributors:

Editing	Jean-Christophe Cauvin: HPRIM, Medasys Shigeo Hasegawa: JAHIS, Olympus François Lecertisseur: HPRIM, Technidata René Spronk: HL7 Netherlands, Ringholm Yoshi Takagi: JAHIS, Hitachi
Content review	Olivier Boux: CHRU de Strasbourg Alain Coeur: HPRIM, Alain Coeur Conseil Hans Houben: HL7 Netherlands, Philips Med Syst Martine Marchand: SFIL Patrick Mitchell-Jones: HL7 UK Martine Otter: SFIL Sadamu Takasaka: JAHIS, NEC
Language review	Trevor Steele: Technidata
Overall review	Chris Carr: IHE International, RSNA Charles Parisot: IHE International, General Electric
Tools & environment editing	Eric Poiseau: IHE Europe, Université de Rennes
Meetings & document management	François Macary: HPRIM, europMedica
Project management	Karima Bourquard: GMSIH

1.3 Audience

The intended audience of this document is:

- Technical staff of vendors participating in the IHE initiative
- IT departments of healthcare institutions
- Experts involved in standards development
- Anyone interested in the technical aspects of integrating healthcare information systems.

1.4 Relationship to Real-world architectures

- 0 The IHE Actors and transactions are abstractions of the real-world healthcare information system environment. While some of the transactions are traditionally performed by specific product categories (e.g. HIS, Electronic Patient Record, Clinical Information System, LIS, LAS, analyzer, robotic transportation system and other pre and post-analytic process equipment), the IHE Laboratory Technical Framework intentionally avoids associating functions or actors with such product categories. For each actor, the IHE Laboratory Technical Framework defines only those functions associated with integrating information systems. The IHE definition of an actor should therefore not be taken as the complete definition of any product that might implement it, nor should the framework itself be taken to comprehensively describe the architecture of a healthcare information system.

1.5 Conventions

- 0 IHE Laboratory Technical Framework adopts without any change, the conventions defined in IHE radiology Technical Framework Rev. 5.5. See paragraph 1.6 in volume 1 of that document.

1.6 Comments

JAHIS, GMSIH , HIMSS and RSNA welcome comments on this document and the IHE initiative. They should be directed to

Karima BOURQUARD

374, rue de Vaugirard

75015 PARIS

Email : karima.bourquard@gmsih.fr

Comments may also be addressed to the IHE Laboratory international mailing list:

0 ihe-intl-lab@listes.univ-rennes1.fr

1.7 Copyright permissions

Health Level Seven Inc. has granted to the IHE to reproduce tables from the HL7 standard. The HL7 tables in this document are copyrighted by Health Level Seven Inc. All rights reserved.

IHE grants permission to Health Level Seven Inc. and its affiliate organizations to reproduce either parts of this document or the document in its entirety.

0 1.8 IHE Technical Framework Development and Maintenance Process

The IHE Laboratory Technical Framework is being continuously extended and maintained by the IHE Laboratory Technical committee. The development and maintenance Process of the framework follows a number of principles, which were defined in the Radiology Technical Framework version 5.5, 2003, chapter 1.10 IHE Technical Framework development and Maintenance Process.

2 Integration profiles

2.1 Scope

Laboratory Technical Framework describes the integration of the clinical laboratory in the healthcare enterprise.

0 Basically, the clinical laboratory receives orders for the performance of tests from clinical departments or from physicians, concerning their patients. The tests are usually performed on specimens collected from the patient. Depending on the organization the laboratory can receive orders for which it is responsible for collecting the specimens, as well as orders accompanied by the specimens to be analyzed. In the latter case the specimen may arrive before or after the order.

For the purpose of messaging, the identification of specimen containers is essential. The exact details of the labeling process are however out of the scope of this framework.

Workflow includes the laboratory's ability to accept, modify, or reject an order, with appropriate notification to the Order Placer.

0 The tests produce observation results which can be of various natures: from simple numeric quantitative measurement such as a blood serum glucose level, to a complex diagnostic pathology report such as a bone marrow biopsy. Some of these results may carry images or graphs, for example blood serum protein electrophoresis. Results are sent to the ordering clinical department; copies may be sent to other physicians or departments, and may also be stored in an electronic healthcare record.

Observation results may be generated for both ordered and unordered tests.

Observation results progress through different steps of validation:

A **non-validated result** is acquired from the analyzer, without any human acceptance.

A **technically validated result** has been accepted by the laboratory technician who ensures that this result has been obtained through the correct analytic procedures, taking into account quality control results, together with other criteria.

0 A **clinically validated¹ result** has been accepted and interpreted by a clinical expert. Clinical validation¹ includes interpretation of the result. The clinical expert considers the consistency of the whole order, with the biological history, the available clinical and therapy information. The clinical expert may be helped in this step by an expert system that applies rules and reasoning to validate common or simple cases.

The laboratory usually delivers results only after clinical validation. Under some conditions (e.g. emergency) or in agreement with a care department, it may also deliver results as soon as they are technically validated. In this case, it will confirm the validity of the results after their clinical validation has occurred.

The exchange of code sets and associated rules shared by multiple actors is beyond the scope of this integration profile. It is however assumed that the actors use common code sets when required.

0

¹ See the definition of those terms in the glossary at the end of this volume.

2.2 Laboratory specialties

Not all laboratory specialties will be covered by the current framework: The 2003-2004 IHE cycle covers the workflow of disciplines that perform tests on specimens drawn from the patient, and not on the patient itself.

The table below, constructed from a subset of HL7 v2.5 Table 0074 “Diagnostic Service Section ID”, points out the lab specialties addressed by the 2003 – 2004 cycle of IHE Laboratory Technical Framework. Other specialties may be added by future IHE cycles.

Table 2.2-1: Non-exhaustive list of specialties

Value	Description	Addressed by Laboratory TF 2003 - 2004
BG	Blood Gases	Yes
BLB	Blood Bank	
CUS	Cardiac Ultrasound	
CTH	Cardiac Catheterization	
CP	Cytopathology	
CT	CAT Scan	
CH	Chemistry	Yes
HM	Hematology	Yes
ICU	Bedside ICU Monitoring	
IMM	Immunology	Yes
LAB	Laboratory ²	Yes
MB	Microbiology	Yes
MCB	Mycobacteriology	Yes
MYC	Mycology	Yes
NMS	Nuclear Medicine Scan	
NRS	Nursing Service Measures	
OSL	Outside Lab	
PF	Pulmonary Function	
SR	Serology	Yes
TX	Toxicology	Yes
VUS	Vascular Ultrasound	
VR	Virology	Yes

0 2.3 Integration Profiles overview

Four Integration Profiles have been considered:

Laboratory Scheduled Workflow: Tests performed by laboratory for an identified inpatient or outpatient.

Laboratory Patient Information Reconciliation: Tests performed for a misidentified or unidentified patient, afterwards matched with the patient record.

Point of Care Testing: Tests performed by medical staff at patient’s bedside, under laboratory supervision.

Inter-Enterprise Testing: Tests performed by an external laboratory

² In this table, “LAB” (laboratory) stands for a multi-disciplinary laboratory.

The first three integration profiles are contained within the healthcare enterprise. The last one involves workflow with an outside laboratory, either standalone, or part of another healthcare enterprise.

- 0 The 2003-2004 Laboratory Technical Framework develops only the first profile: Laboratory Scheduled Workflow. The three others will be implemented during next IHE cycle: 2004 – 2005.

2.4 Actors in Laboratory Technical Framework

ADT: Admission Discharge and Transfer. A system responsible for adding and/or updating patient demographic and encounter information, and delivering this information to Order Placer, Order Filler, Order Result Tracker. This Actor is also present in the Radiology Technical Framework and IT Infrastructure Technical Framework.

- 0 **Order Placer:** A system that generates test orders for various clinical laboratories, distributes those orders to the correct laboratory, and appropriately manages all state changes of those orders. In some cases the Order Placer is responsible for collecting and identifying the specimens. Therefore, the transaction between Order Placer and Order Filler may carry specimen related information. There may be several Order placer actors in the same enterprise.

- 0 **Order Filler:** A system used by a laboratory, that receives test orders from Order Placer actors, collects or controls the related specimens, accepts or rejects the order, schedules work orders, and sends them to one or more Automation Managers, receives the results from each Automation Manager, performs the clinical validation, appropriately manages all state changes of the order and sends the results to the Order Result Tracker(s). In some cases, the Order Filler will create test orders itself (e.g. a paper order received by lab from a department not connected to an Order Placer, or a paper order was received from a physician external to the organization). In some cases the Order Filler is responsible for collecting and identifying the specimens. An Order Filler may receive test orders from various Order Placers and may send the order results to several Order Result Trackers.

Automation Manager: A system or component that manages the automation in the laboratory or a part of it. Automation involves the integration or interfacing of automated or robotic transport systems, analytical instruments, and pre- or post-analytical process equipment such as automated centrifuges and aliquoters, decappers, recappers, sorters, and specimen storage and retrieval systems. This actor receives work orders from the Order Filler. It manages the processing of the ordered tests on the appropriate devices, and sends technically validated results back to the Order Filler. This actor must be considered even if it manages a small part of the analytical process; e.g. if it manages one single analytical instrument. Multiple Automation Managers can be related to one Order Filler.

- 0 **Order Result Tracker³:** A system that stores observations of various types (test results, images, clinical examinations reports, radiology reports, surgical act reports...) obtained for the patients, registers all state changes in the results notified by Order Fillers. This actor doesn't store standalone observations, but ordered observations. The observations are always stored within the context of the order that generated them, with all the information related to that order.

³ This actor is not specific to the Laboratory Technical Framework: It may play the role of "Information Source" actor defined within Retrieve Information for Display Integration Profile (see IT Infrastructure Technical Framework). It may also play the role of Enterprise Report Repository actor defined in Radiology Technical Framework.

3 Laboratory Scheduled Workflow

The *Laboratory Scheduled Workflow* Integration Profile establishes the continuity and integrity of clinical laboratory testing and observation data throughout the healthcare enterprise. It involves a set of transactions, to maintain the consistency of ordering and patient information, to control the conformity of specimens, and to deliver the results at various steps of validation. Some of these transactions are already defined in the IHE Radiology Technical Framework. This profile also enables automation of pre-analytical, analytical and post-analytical processes within the laboratory.

3.1 Use cases

In the three use cases that follow, the Order Placer, Order Filler and Order Result Tracker Actors are assumed to be provided by the ADT Actor (Admission-Discharge-Transfer) with up-to-date patient information. For a global overview of actors/transactions the reader is invited to refer to Figure 3.3-1.

3.1.1 Externally placed order with identified specimens

Initial part of the scenario, specific to this use case:

A physician in a care department prescribes laboratory tests (or batteries) for a patient. The order is entered into the Order Placer with all pertinent information. Using rules established by the laboratory (in the Order Placer's dictionary), the Order Placer determines what specimens are required to perform the tests, with collection (container type, preservative/anticoagulant, volume, time and patient status) and transportation conditions. The Order Placer also provides specimen identification labels which can contain a unique specimen ID (usually bar coded), a placer order ID, the patient identification (PID, name, visit number ...) and may identify the ordered batteries related to this specimen. The medical staff of the care department collects the specimens and identifies each one by placing the appropriate label on the container(s) and sends the specimens to the laboratory where the Order Placer has sent the order to the Order Filler. The sequencing of the material flow (the specimens) and of the electronic flow (the order) is not necessarily synchronized. It depends upon the healthcare organization. The laboratory staff opens the placer order using the Order Filler application, and ensures that all required specimens are available and conform to the order. The order is then rejected or accepted with modifications if needed. The order is then generated and scheduled by the Order Filler which then informs the Order Placer. Should a specimen be damaged or lost, the Order Filler requests a new one from the Order Placer and the requested batteries of tests remain unscheduled until the replacement specimen arrives.

In this use case the enterprise must use a specimen identification mechanism that ensures enterprise-wide unique identifiers of all specimens. The Order Placer and Order Filler actors must agree the structure of specimen ID that is compatible with the laboratory organization and Automation managers. For example, the laboratory automation system may have limited capabilities when it comes to the length of the specimen ID number or the format of the bar code label that can be read. The specimen ID shall be unique for the lifetime of the specimen.

Middle part of the scenario, shared by all three use cases:

The Order Filler splits the order into one or more Work Orders sent to the Automation Manager. The technical staff of the laboratory fulfills the various Work Orders using the Automation Manager and all necessary devices (aliquoters, robotic systems, analyzers...). The splitting of samples (aliquoting) may require the printing of additional labels (either by the Order Filler or by the Automation Manager), for the identification of aliquot containers. The technical staff performs a technical validation of the results generated and the Automation Manager sends back the results to the Order Filler. A clinical expert performs the clinical validation of the results using the Order Filler application.

Final part of the scenario, shared by all three use cases:

- 0 At various steps (depending on the organization), the Order Filler sends results to the Order Result Tracker, and notifies both Order Placer and Order Result Tracker of all status changes to the order or the result. The order and the result have each a final status. This final status is either “completed” or “cancelled” or “nullified” (i.e. a result has been issued but indicated at a later stage to be void) .

3.1.2 Externally placed order with specimens unidentified or to be collected by the laboratory

Initial part of the scenario, specific to this use case:

A physician in a care department prescribes laboratory tests for a patient. The order is entered into the Order Placer application with all pertinent information. The Order Placer does not identify the specimens. Three different sub-use cases should be considered for the identification and collection of specimens:

- 0
1. The care unit collects and supplies specimens labeled with an identification limited to patient ID and placer order ID. The Specimens are subsequently re-identified by the Order Filler and labeled with bar coded specimen ID, by the laboratory staff for processing.
 2. The laboratory is in charge of the collection and identification of specimens. This task being performed by specialized staff of the laboratory⁴.
 3. The care unit collects the specimens using a list of required specimens and labels created by the Order Filler (based on information received from the Order Placer) and delivered to the care unit staff (e.g. via. remote printing on the ward)⁵.

0 In all three sub-cases, specimens are eventually identified by the Order Filler with labels. The label shall contain:

- the unique specimen ID (usually bar coded for the automation),

Optionally, it may contain:

- the filler order ID,
- the patient identification,
- the responsibility identification (care unit or physician, see data model Figure 3.4-1),
- the ordered batteries,
- the order placer ID,
- ...

The middle and final part of this use case is the same as in use case 3.1.1.

3.1.3 Filler order with specimens identified by third party or collected by the laboratory

Initial part of the scenario, specific to this use case:

Two different sub-use cases should be considered :

1. The laboratory staff receives an order in paper form from a care unit unable to access the Order Placer application.
2. During the processing of a group of orders, the laboratory decides to add a new order to that group. The new order is to be performed on one of the existing specimens of the group.

⁴ This case is frequently met in northern Europe and the US.

⁵ This use case has been seen in Canada and in some organizations in France. The care unit staff, under requirements of the Order Filler, performs specimen collection and identification.

In both sub-use cases, the generated order has a filler order number. The Order Filler application notifies the Order Placer application of this filler order. The Order Placer application creates the placer order, and sends back the placer order number to the Order Filler.

New specimens (if any) are identified by the Order Filler with the appropriate labels (bar code specimen ID, filler order ID, patient identification,).

The middle and final part of this use case is the same as in use case 3.1.1. The figure below shows the overlapping steps of the three use cases.

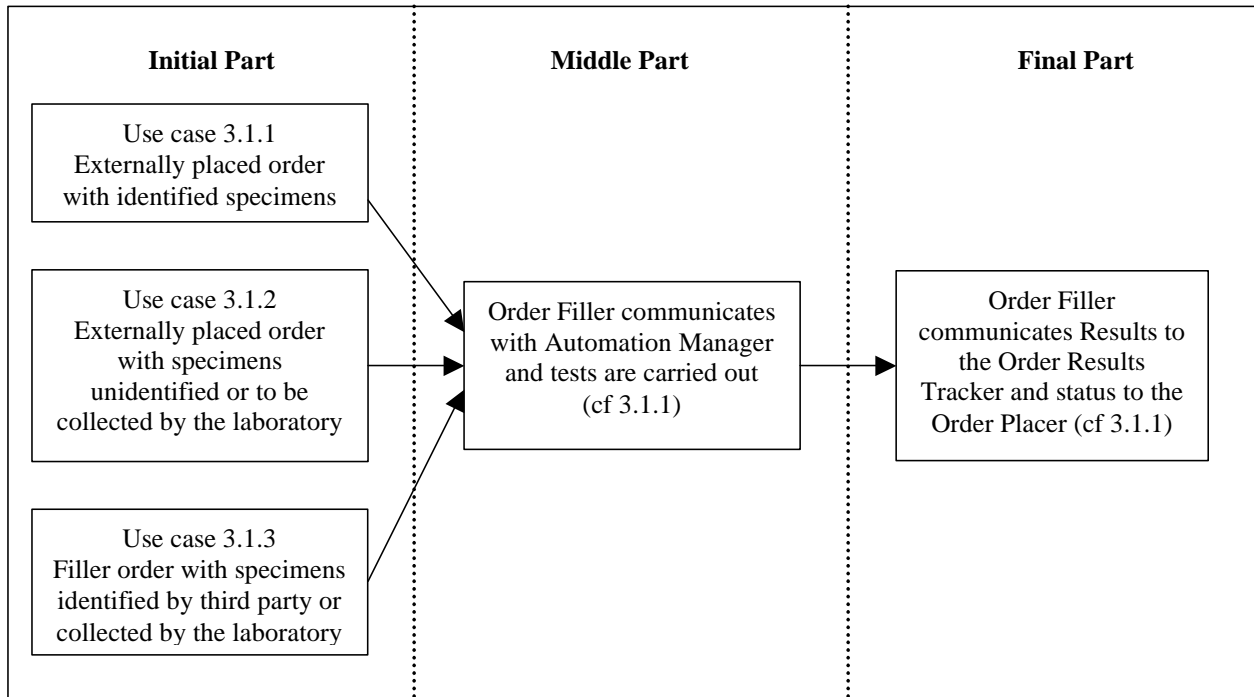

Figure 3.1-1 – Overlapping of the three use cases

3.2 Laboratory specialties/Use cases

- 0 The table below lists the 12 disciplines covered by this Laboratory Scheduled Workflow Integration Profile, with their ability to support the different use cases.

Table 3.2-1: List of supported specialties and supported workflow use cases

Value	Discipline	Externally placed order with identified specimens	Externally placed order with specimens unidentified	Filler order
BG	Blood Gases	Yes	Yes	Yes
CH	Chemistry	Yes	Yes	Yes
HM	Hematology	Yes	Yes	Yes
IMM	Immunology	Yes	Yes	Yes
LAB	Laboratory	Yes	Yes	Yes
MB	Microbiology	Yes	Yes	Yes
MCB	Mycobacteriology	Yes	Yes	Yes
MYC	Mycology	Yes	Yes	Yes
SR	Serology	Yes	Yes	Yes
TX	Toxicology	Yes	Yes	Yes
VR	Virology	Yes	Yes	Yes

3.3 Actors/Transactions

Figure 3.3-1 indicates the actors involved with the Laboratory Scheduled Workflow and the transactions between them.

The transactions initiated by actor ADT “*Patient registration [RAD-1]*” and “*Patient update [RAD-12]*” have already been defined in Radiology Scheduled Workflow (see Radiology Technical Framework volume 1). These two transactions are adopted here without any modification.

The Laboratory Scheduled Workflow introduces 5 new transactions numbered LAB-1 through LAB-5.

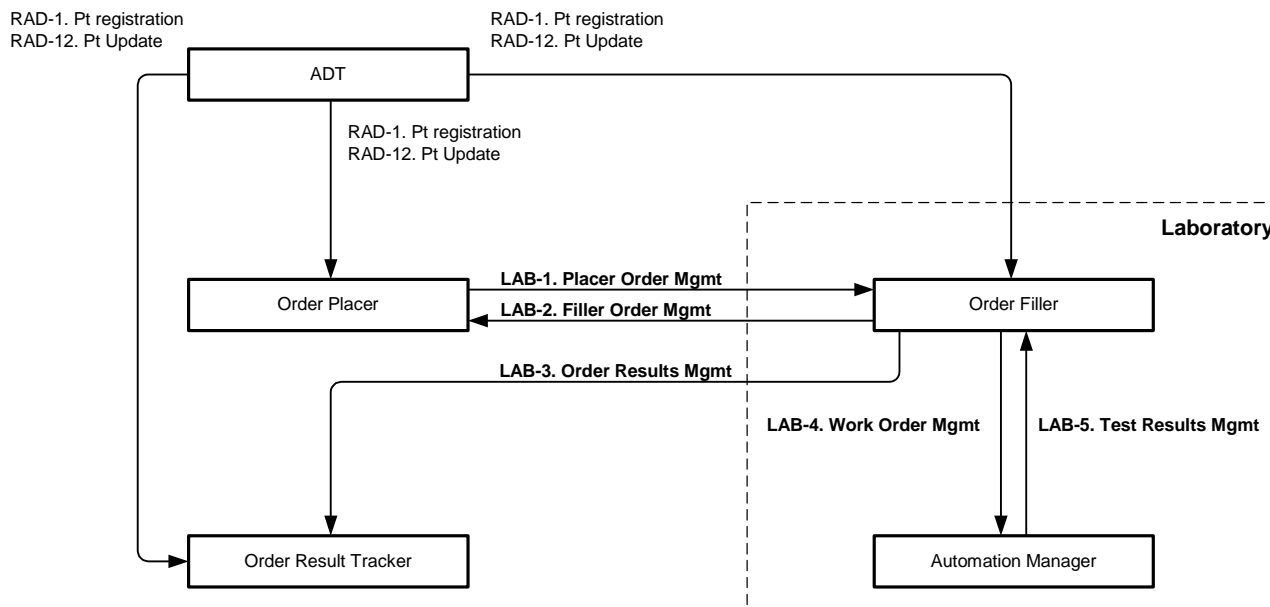

Figure 3.3-1: Laboratory Scheduled Workflow Diagram

The current document does not define transactions between the Automation Manager and the analytical instruments or other equipment. These transactions will be defined in a future version of this document. In the present version, the Automation Manager is an actor grouping all the automated devices used for the analysis process.

Notes on new transactions introduced by Laboratory Scheduled Workflow:

LAB-1: Placer Order Management: This transaction contains all the messages required between the Order Placer and the Order Filler for the management of the life cycle of the order. Its main goal is to keep a consistent vision of the order, (content and status), between the two actors.

LAB-2: Filler Order Management: This transaction contains all the messages required between the Order Filler and the Order Placer for the notification of a new filler order, as well as the creation of the placer order that reflects it. Its main goal is to ensure that each filler order will be represented by a placer order, and will have both a filler order number and a placer order number.

LAB-3: Order Results Management: This transaction carries changes of the observation results and order status from Order Filler to Order Result Tracker i.e. corrections, cancellations.

LAB-4: Work Order Management: This transaction contain all the messages required between Order Filler and Automation Manager for the execution of a work order containing a subset of

tests of the filler order. The main goal of this transaction is to distribute the work to the Automation Manager, and to keep this actor informed of all patient and order updates. This transaction will be based on a push mechanism, the query mechanism never being used in this transaction.

LAB-5: Test Result Management: This transaction carries the technically validated test results from the Automation Manager to the Order Filler.

0

Table 3.3-1: Laboratory Scheduled Workflow – Actors and Transactions

Actors	Transactions	Optionality	Documentary reference
ADT	Patient registration [RAD-1]	R	Radiology TF vol 2 sect 4.12
	Patient update [RAD-12]	R	Radiology TF vol 2, sect 4.12
Order Placer	Patient registration [RAD-1]	R	Radiology TF vol 2 sect 4.12
	Patient update [RAD-12]	R	Radiology TF vol 2, sect 4.12
	Placer Order management [LAB-1]	R	Laboratory TF vol 2, sect 4
	Filler Order Management [LAB-2]	R	Laboratory TF vol 2, sect 5
Order Filler	Patient registration [RAD-1]	R	Radiology TF vol 2 sect 4.12
	Patient update [RAD-12]	R	Radiology TF vol 2, sect 4.12
	Placer Order management [LAB-1]	R	Laboratory TF vol 2, sect 4
	Filler Order Management [LAB-2]	R	Laboratory TF vol 2, sect 5
	Order result management [LAB-3]	R	Laboratory TF vol 2, sect 6
	Work order management [LAB-4]	R*	Laboratory TF vol 2, sect 7
	Test result management [LAB-5]	R*	Laboratory TF vol 2, sect 8
Automation Manager	Work order management [LAB-4]	R	Laboratory TF vol 2, sect 7
	Test result management [LAB-5]	R	Laboratory TF vol 2, sect 8
Order Result Tracker	Patient registration [RAD-1]	R	Radiology TF vol 2 sect 4.12
	Patient update [RAD-12]	R	Radiology TF vol 2, sect 4.12
	Order result management [LAB-3]	R	Laboratory TF vol 2, sect 6

R*: In case the LIS supports the capabilities of both Order Filler and Automation Manager actors, Transaction LAB-4 and LAB-5 are irrelevant. These transactions must however be supported by the Order Filler when a separate Automation Manager is present in the laboratory.

3.4 Data model

The data model described in this section is related to the information conveyed in the Transactions that flow between the Actors. It is not intended to constrain in any way the internal database model of a particular system or actor. It is a communication model. Moreover, this communication model has no pretension to compete with either the HL7 v3 RIM or its derived Laboratory DMIM. The goal of this model is to help the system vendors to implement the actors and the transactions in their systems, and the IT departments to use it as a reference within their healthcare institution.

The data model is based on the following assertions:

- In this Integration Profile a patient is identified by the ADT actor as either an admitted patient (inpatient) or non-admitted patient (outpatient), with a current visit and a current location, under the medical responsibility of a care department.
- Various responsibilities can be defined for the patient during his visit. For instance the medical responsibility, the care responsibility, and the hosting responsibility. Location is a part of the hosting responsibility identified for example by building, floor, room, bed ... The patient location is important not only for the correct delivery of results, or specimen collection, but also for epidemiological reasons. For instance the microbiology laboratory requires this information to detect and track in-hospital diseases (nosocomial infections). Depending on the organization, each of these responsibilities may be assumed by a physician, a care unit, or by both.
- A placer order is prescribed by a physician and ordered by a care unit, for a subject that can be a material (air, water, surgical instrument, food, medicine,) or a living subject (the patient). In the latter case, the order is attached to the current patient visit and to the current patient location.
- The placer order has a unique enterprise-wide key, the placer order number.
- A placer order is translated into one filler order, unless it is cancelled before its placing, or if the laboratory staff rejects it.
- Equally, a filler order is associated with only one placer order.
- Orders are identified by two unique enterprise-wide keys: the filler order number and the placer order number.
- In this 2003 – 2004 IHE cycle, a filler order is considered as handled by one clinical laboratory.
- A “work order” is a subset of a filler order, sent by the Order Filler actor to the Automation Manager actor. One filler order may result in 0 or more work orders. In some cases the work order may be identical to the filler order, in some other cases, the work order may contain only the tests sent to a single analyzer.
- The order contains a battery composed of one or more tests. For example blood cell count, serum electrolytes, protein electrophoresis, serum glucose level, serum potassium level. A battery can also be composed of other (smaller) batteries.
- An individual test can form part of more than one battery. For example in chemistry, serum potassium level is part of the “3 ions serum electrolyte” battery, as well as of the “complete serum electrolyte battery”. In hematology, a platelets count can be a battery containing only this test, as well as forming part of a “complete blood cell count” battery that comprises additional tests.
- In chemistry, hematology, immunology, virology, an ordered test produces most often one single observation. Generally, the tests that measure or compute something on the specimen produce one single result. But there exist examples of ordered tests producing several observations. These examples concern tests that “detect something” or “identify something” on the specimen. For example in microbiology the test “detection of bacterium” can indicate two findings

- 0 “staph.aureus” and “e.coli”. Similarly in hematology the test “identification of abnormal white cells” may indicate two findings, “erythroblasts” and “atypical leucocytes”. For this reason, the test is associated with 0 to n observations in the data model.
- An observation may be generated in various ways, depending on the test. It may be produced through a manual technique or examination, through a processing on an automated analyzer, or it may be computed through an arithmetic/logical calculation using other tests results as input operands, or it may be a qualitative interpretation of a numeric result, or a text comment provided by a technician or by a clinical expert.
 - In the case of an observation generated from an automated analyzer, several passes on the analyzer may be necessary to produce an acceptable observation. For example a second pass after dilution of the specimen may be required if the first pass indicated a result outside of the analytical range for the test concerned.
 - The prime objective of technical validation is to ensure that results/observations have been arrived at in conformance with defined procedures and having satisfied quality control and other validation criteria such as an acceptable variation of the result from the previous result for the same test.
 - An ordered battery normally needs one specimen to be collected from the patient. Some tests, for example glucose tolerance series requires several specimens to be collected at defined intervals. Also a creatinine clearance requires both a urine and serum specimens to be collected. The specimen collected directly from the patient is called the “primary specimen”.
 - Depending on the healthcare organization, and the disciplines concerned, tests may be measured on the “primary specimen” (or on one or more “aliquoted specimens” of the primary specimen, with a possible preparation step involved prior to processing such as centrifugation or dilution.
 - Clinical validation is a process that generally applies to the whole filler order or group of orders and takes into consideration the biological coherence of the results together with the clinical information available on the patient to facilitate interpretation as well as potential follow up actions that may be required. In some cases this operation can be performed on subsets of the results, in order to allow faster availability of for example critical results (e.g. blood gases) or those which take a short time to generate. Thus, a multi-disciplinary laboratory can be organized with a clinical expert per discipline, each one validating the batteries specific to his knowledge domain, so that in the end, the filler order may have been validated by several clinical experts.
 - A battery may be generated during analytical process from an intermediary observation. For example in bacteriology, testing for antibiotic susceptibilities is generated whenever a “gram-negative bacterium” is found.

The above assertions enable the Laboratory Scheduled Workflow Data Model to be expressed as a simplified UML (Unified Modeling Language) class diagram below. Class properties are not shown in this diagram.

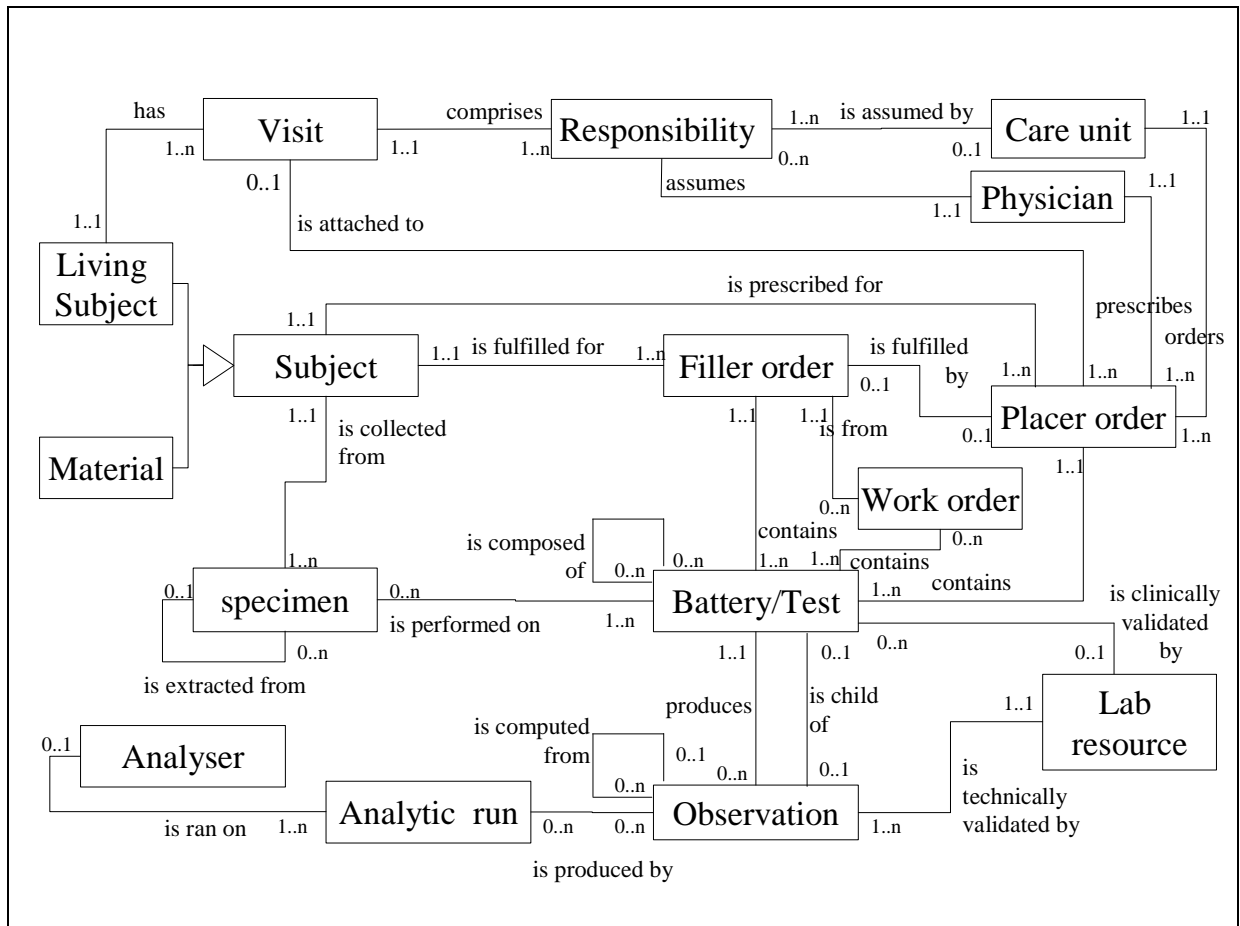

Figure 3.4-1: Laboratory Scheduled Workflow Data Model

3.5 Process Flow

Process flow is expressed with the following UML sequence diagrams, with time scale from top to bottom.

These diagrams present a high-level view of the flow: Each transaction is represented by a single arrow with the initial triggering event, but without any detail on the various messages that compose the transaction. For instance, transaction [LAB-1] starts with the placing of an order, but the message flow of this transaction keeps going on until the order is completed, cancelled, or nullified. Individual messages aren't shown, the detailed message flow of each transaction can be found in volume 2.

3.5.1 Laboratory Scheduled Workflow with the first two use cases: placer ordering

0 Figure 3.5-1 represents the basic process flow for use case 3.1.1 and use case 3.1.2.

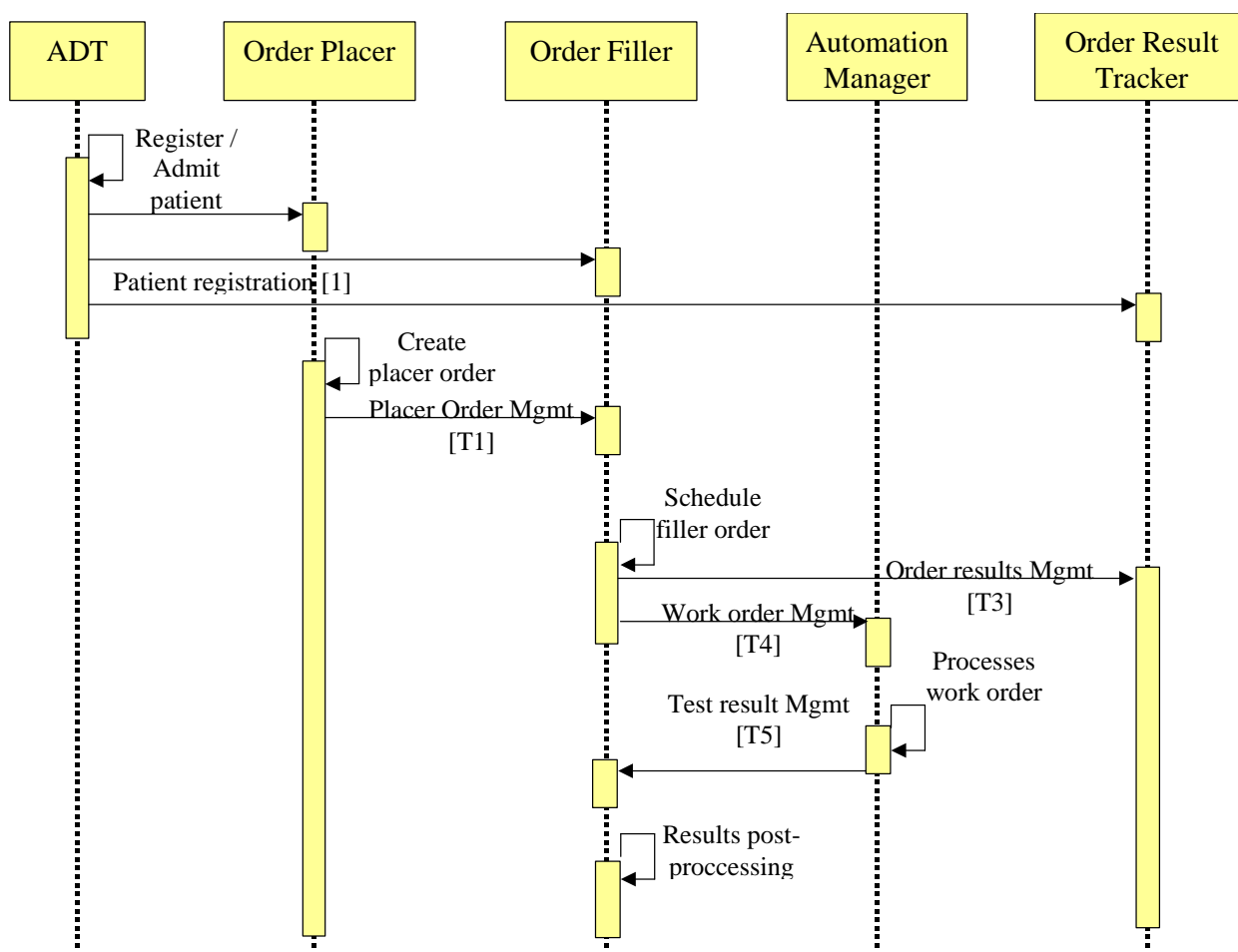

Figure 3.5-1: Process flow for placer ordering

3.5.2 Laboratory Scheduled Workflow with the third use case: filler ordering

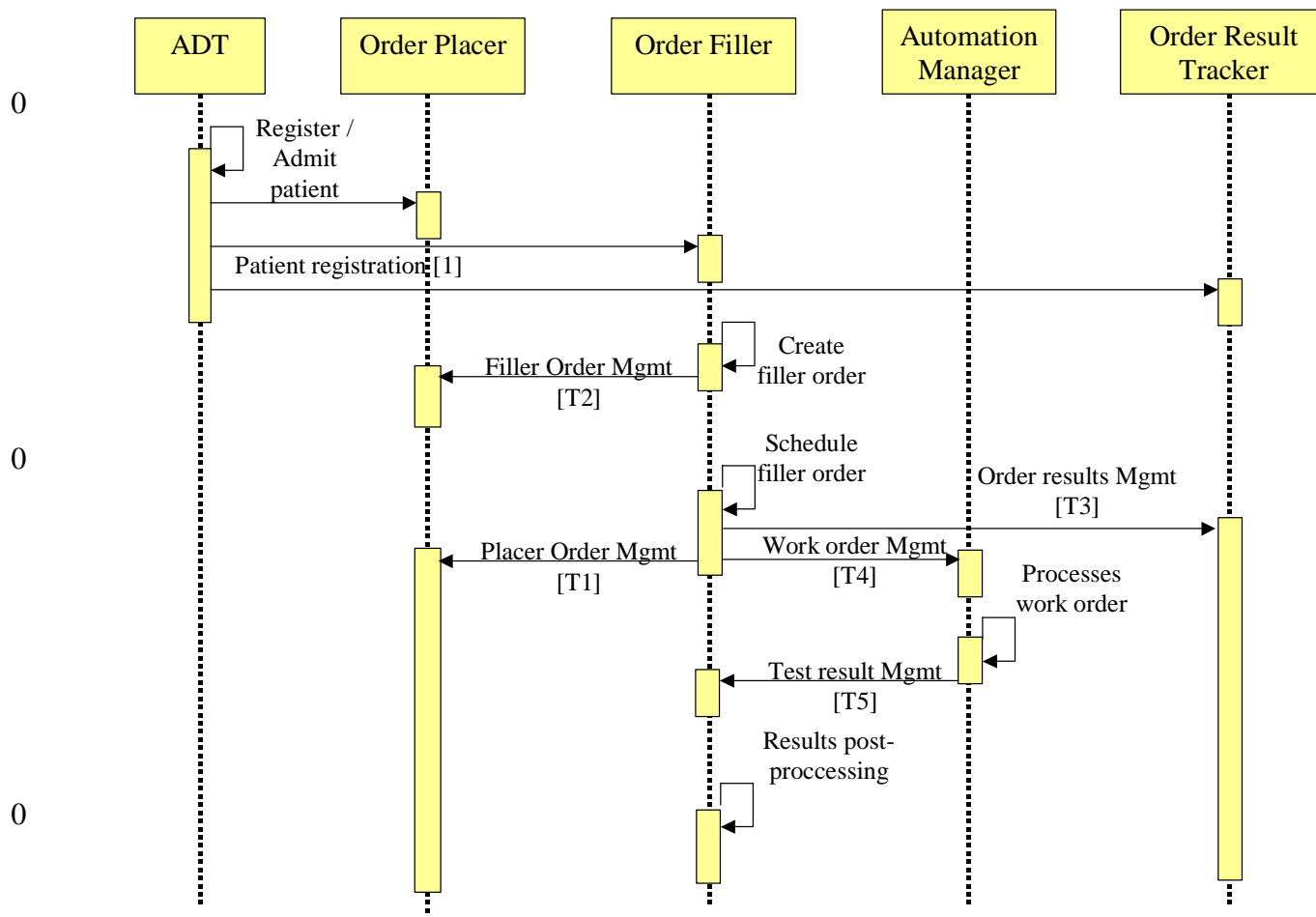

Figure 3.5-2: Process flow for filler ordering

Note: In this general use case, the order is first created with a filler order number on the Order Filler side, and then granted a placer order number by the Order Placer. With this step achieved, transaction LAB-2 has fulfilled its mission: Both Order Placer and Order Filler know the order. In the next step, the laboratory schedules the order, and notifies this "Status change" to the Order Placer through an initial message of transaction LAB-1. In this particular case, transaction LAB-1 starts with a message sent by the Order Filler to the Order Placer. That's why the arrow "LAB-1" on the diagram is oriented towards the Order Placer. Nonetheless, Transaction LAB-1 is still dedicated to the "Placer Order Management", and it goes on until the end of the process of the order, involving messages from both parts, just like in the "Placer Ordering" process flow.

3.5.3 Patient update flow

These cases cover the situations where patient information updates are introduced into the system at the various stages of the analytical process. Only the impacted parts of the previous flow diagrams are presented below. All subsequent steps progress according to the previously presented work flow diagrams.

3.5.3.1 Patient information update before creation of an order

- 0 This case impacts placer ordering and filler ordering in the same way. Only the example of placer ordering (corresponding to the first two use cases) is shown here:

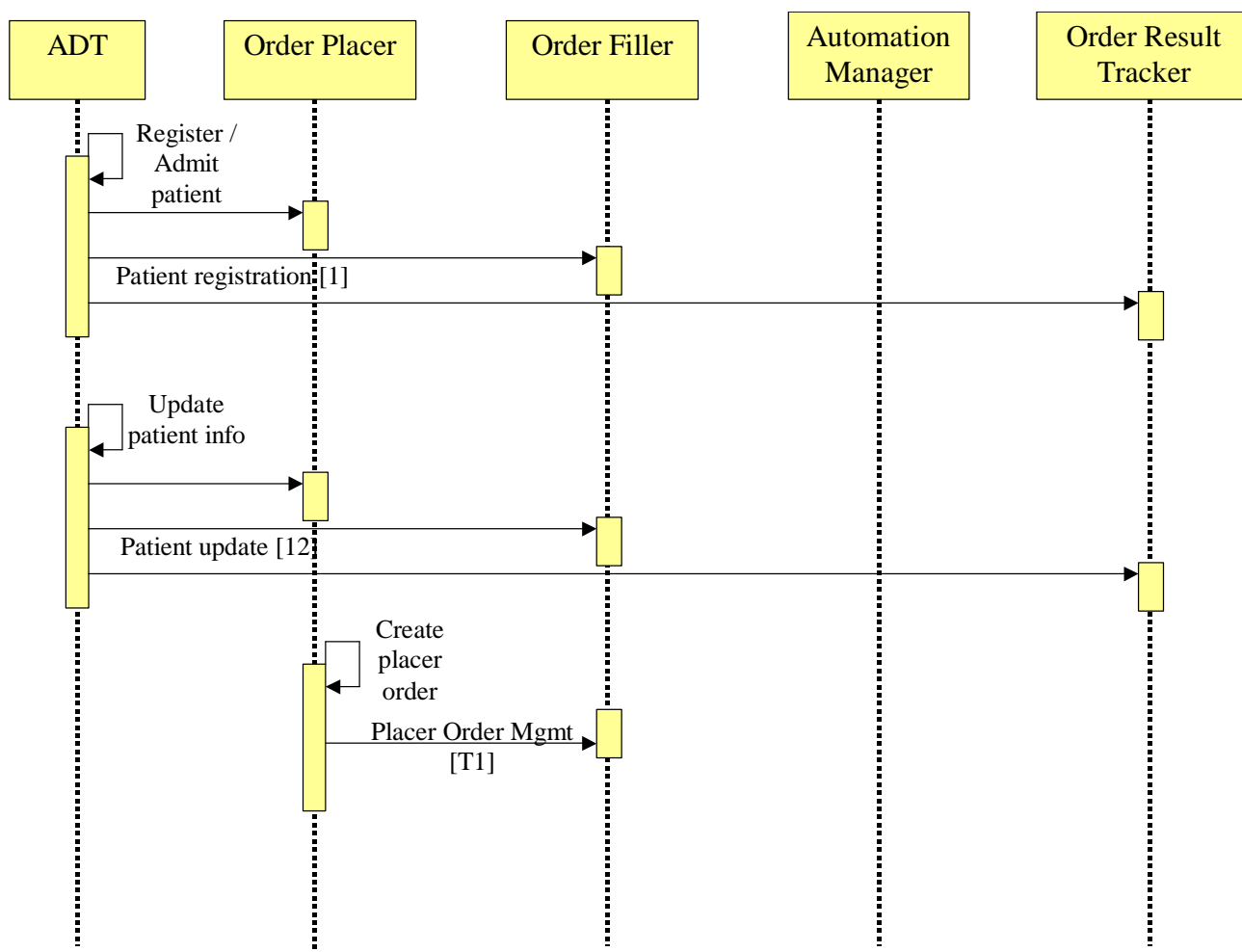

Figure 3.5-3: Patient update before placer ordering

3.5.3.2 Patient information update after creation of an order

This case impacts placer ordering and filler ordering in the same way. Only the example of placer ordering (corresponding to the first two use cases) is shown here. The beginning of the flow (patient registration and transaction [RAD-1]) is also not shown on the diagram:

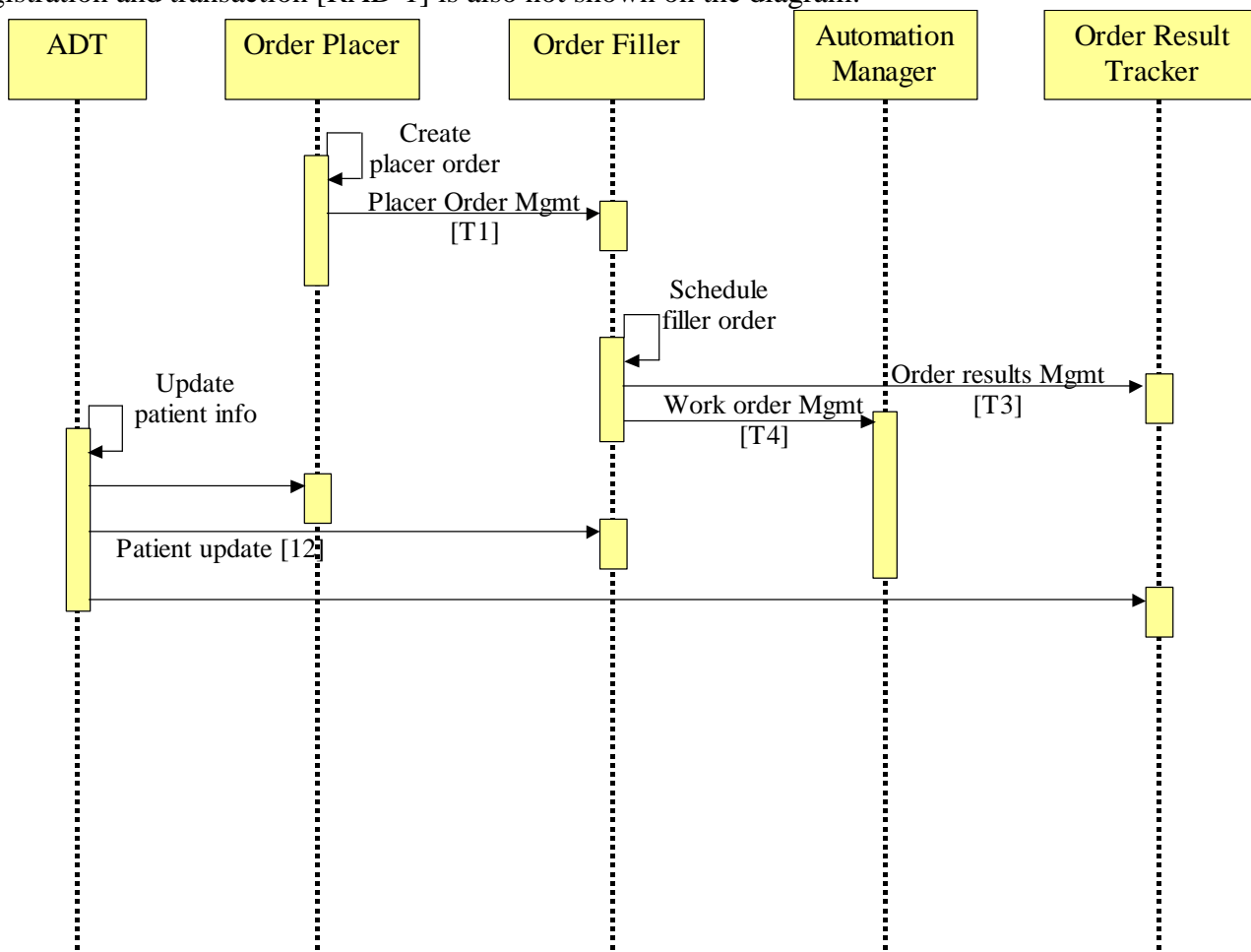

Figure 3.5-4: Patient update after placer ordering

Notes:

As shown, the actors Order Placer, Order Filler, and Order Result Tracker are directly provided by ADT with up-to-date patient information.

The Automation Manager receives the patient update information from the Order Filler using a message of transaction LAB-4. The Order Filler must generate this message to the Automation Manager, upon receipt of the patient update, unless no work orders concerning this patient have been communicated to the Automation Manager.

The reconciliation of the new patient information is done by the Order Placer, the Order Result Tracker and the Order Filler. The reconciliation also takes place in the Automation Manager as long as the work orders related to the patient have not been completed.

3.5.3.3 Patient information update after fulfillment of the order

This case impacts placer ordering and filler ordering in the same way. Only the example of placer ordering (corresponding to the first two use cases) is shown here. The beginning of the flow (patient registration and transaction [RAD-1]) is not shown on the diagram:

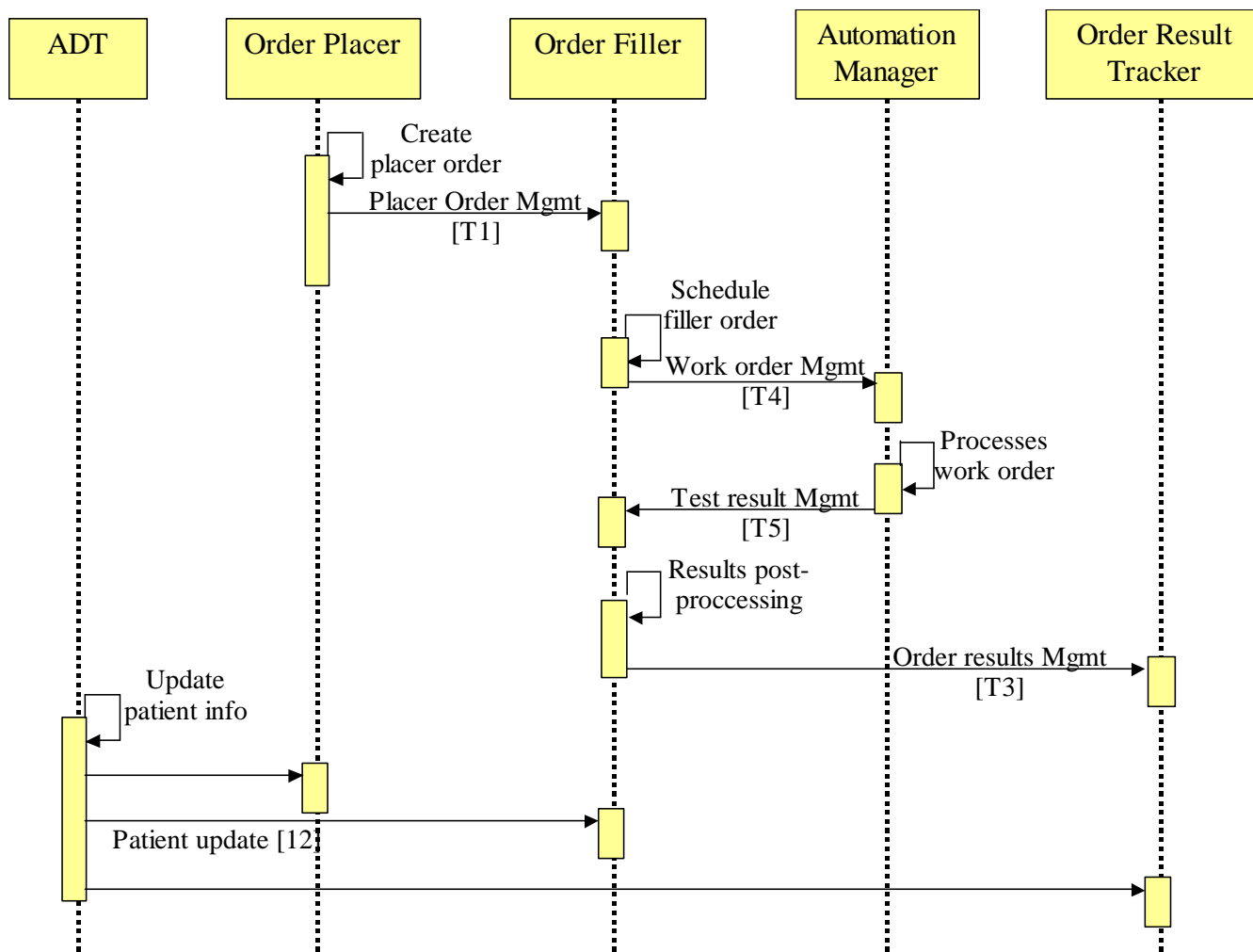

Figure 3.5-5: Patient update after fulfillment of the order

Notes:

- 0 As shown, the actors Order Placer, Order Filler, and Order Result Tracker are directly provided by ADT with last up-to-date patient information.
- In the case where the Automation Manager has finished its work with this order and patient, there is no need to be informed of the patient update. It will receive new patient information, only when a new work order concerning this patient has to be performed.

3.5.4 Order/result update, status change, cancellation, exceptions management

0 Order or result update flow is not visible at the high-level view, e.g. at the transaction level presented by this volume. There is no specialized transaction dedicated to order/result updating (as it is for patient update with transaction [2]). Conversely, order/result update events are carried by the existing generalist transactions [LAB-1] through [LAB-5]. The flow of these order/result update (and order cancelled) events appears at the message level, and is therefore discussed in Volume 2 with a detailed description of each transaction.

The goal remains unchanged: Every update, cancellation or status change that happens to an order or result within an actor, must trigger all the appropriate messages to push this update to the other actors concerned by this order, so that consistency of the order/result is preserved between all the actors that interact with it.

For the same reason the exceptions management concerning the specimens (i.e. non-conformities, lost or damaged container) or concerning the prescription (batteries rejected by laboratory) does not appear at the transaction level (no specific transaction exists), and is therefore discussed in Volume 2 with a detailed description of each transaction.

0 4 Glossary

Battery: One or more laboratory tests, identified by a single name that can be ordered to a laboratory. For example: « Serum electrolyte » is a battery that usually comprises the tests for sodium, potassium, chloride and bicarbonate ions and that can be ordered to a chemistry laboratory on a blood serum specimen. Potassium can be ordered individually, and therefore is also represented by the term battery.

Clinical expert: The person who assumes the overall responsibility for the clinical validation and reporting of an order or a part of it. HL7 speaks of “Result principal interpreter”. Some countries speak of “pathologist”; others use the term “biologist”.

0 **Clinical validation:** the process through which a clinical expert accepts and interprets the results (observations) produced by the laboratory in respect of an order. Interpretation of the results is performed, considering the content of the whole order, together with the biological history, clinical and therapy information known to the clinical expert for the patient. Some countries speak of "biological validation". This step may sometimes be performed by an expert system that uses knowledge based rules and reasoning to interpret the most simple or routine cases. This step of validation is in any case under the laboratory’s responsibility as distinct from the diagnosis and treatment performed by the physician who initially prescribed the order.

Filler order: The order generated by the actor Order Filler on behalf of a placer order received from the actor Order Placer. A filler order may also be directly created by the actor Order Filler, as described in the use case “Filler ordering”.

0 **Placer order:** The order created and handled by the actor Order Placer.

Technical validation: The process through which a laboratory technician accepts a single observation or a set of observations that have been produced either with a manual technique or an automated one, generally under his control. Technical validation ensures that results/observations have been arrived at in conformance with defined laboratory procedures and have satisfied quality control and other technical validation criteria.

Visit: A visit applies to both admitted and non-admitted patients, it is identified by a unique enterprise-wide visit number, and it enables the administrative recording for all acts performed for this patient during his/her stay in the Hospital. For France refer to Volume 4 of Radiology Technical Framework entitled "National Extension for IHE France".

0 **Work order:** A sub-set of batteries and tests extracted from the filler order, and submitted by the actor Order Filler to an actor Automation Manager for processing.

5 Outstanding issues

5.1 Current issues

5.2 Reminder for future cycles

- 0 • The transaction for the Order Filler to know when the specimen reached the analysis section controlled by the Automation Manager may in the future be added by a new scenario, (for example, a status monitor). In the current cycle the arrival of specimen in the laboratory can be implicitly derived from the order status.
- The Automation Manager notifies the test results to the Order Filler. However, in the cases listed below, the Order Filler queries the Automation Manager for test results. A transaction for this will be added by scenario cases.
 1. After the Order Filler fails in reception of the test results due to a problem on transmission, then it is necessary to re-send the missed test results again.
 2. When the Order Filler is able to receive all test results only when it is ready for that.
- 0 • Please note again that the current document does not define transactions between the Automation Manager and the analytical instruments or other equipment. These transactions will be defined in a future IHE yearly cycle.
- 0 • There are some cases where an Automation Manager will communicate with another Automation Manager which communicates with the lab device. This may be a subject for a future cycle.