

# IHE-J Scenario

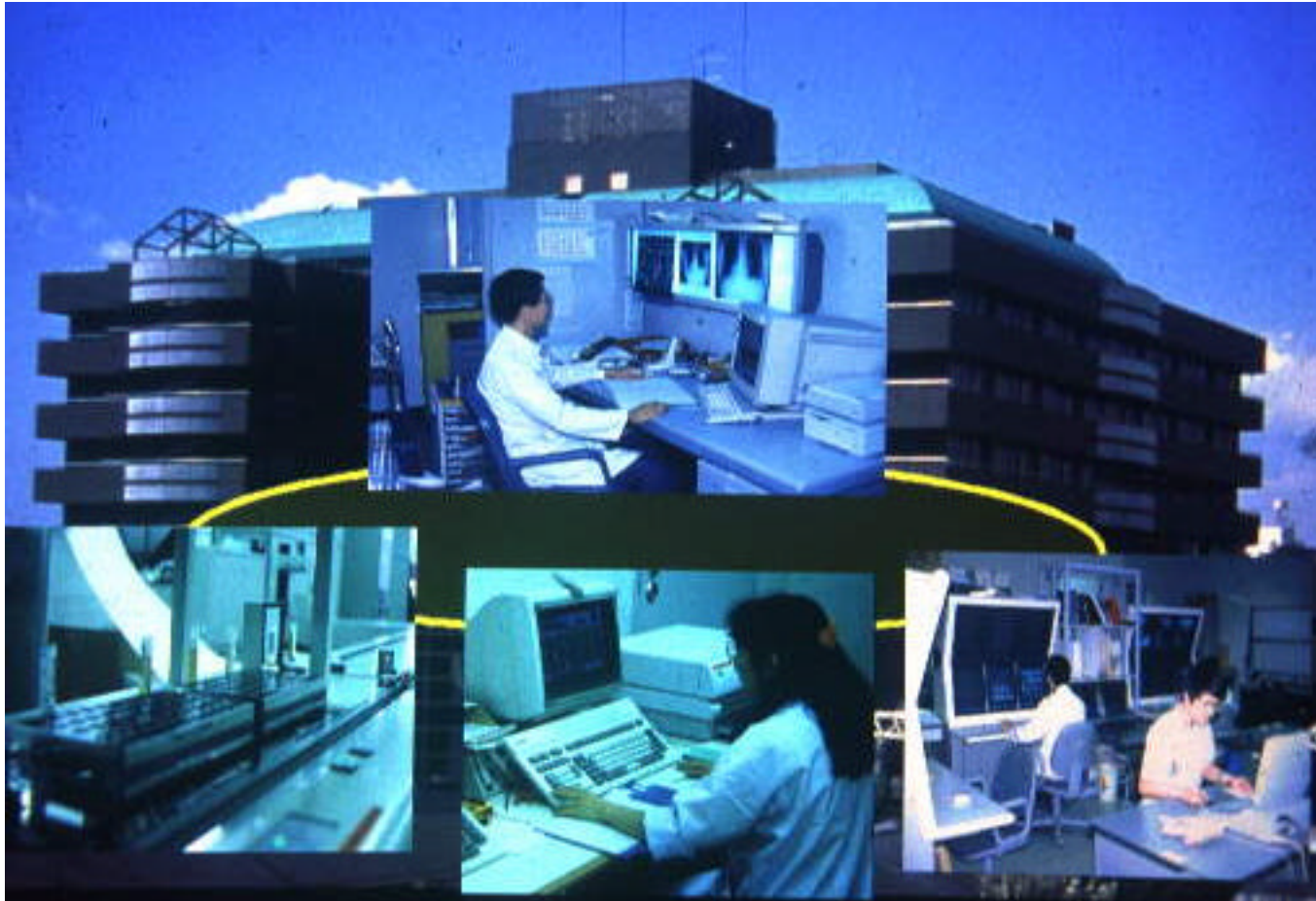

N. Okazaki M.D.

H. Shinoda M.E., Y. Ando M.D., H. Yoshimura M.E.,

1 2 3 4 5 6 7 8 9 10 11 12 13 14 15 16 17 18 19 20 21 22 23 24 25 26 27 28 29 30 31 32 33 34 35 36 37 38 39 40 41 42 43 44 45 46 47 48 49 50 51 52 53 54 55 56 57 58 59 60 61 62 63 64 65 66 67 68 69 70 71 72 73 74 75 76 77 78 79 80 81 82 83 84 85 86 87 88 89 90 91 92 93 94 95 96 97 98 99 100

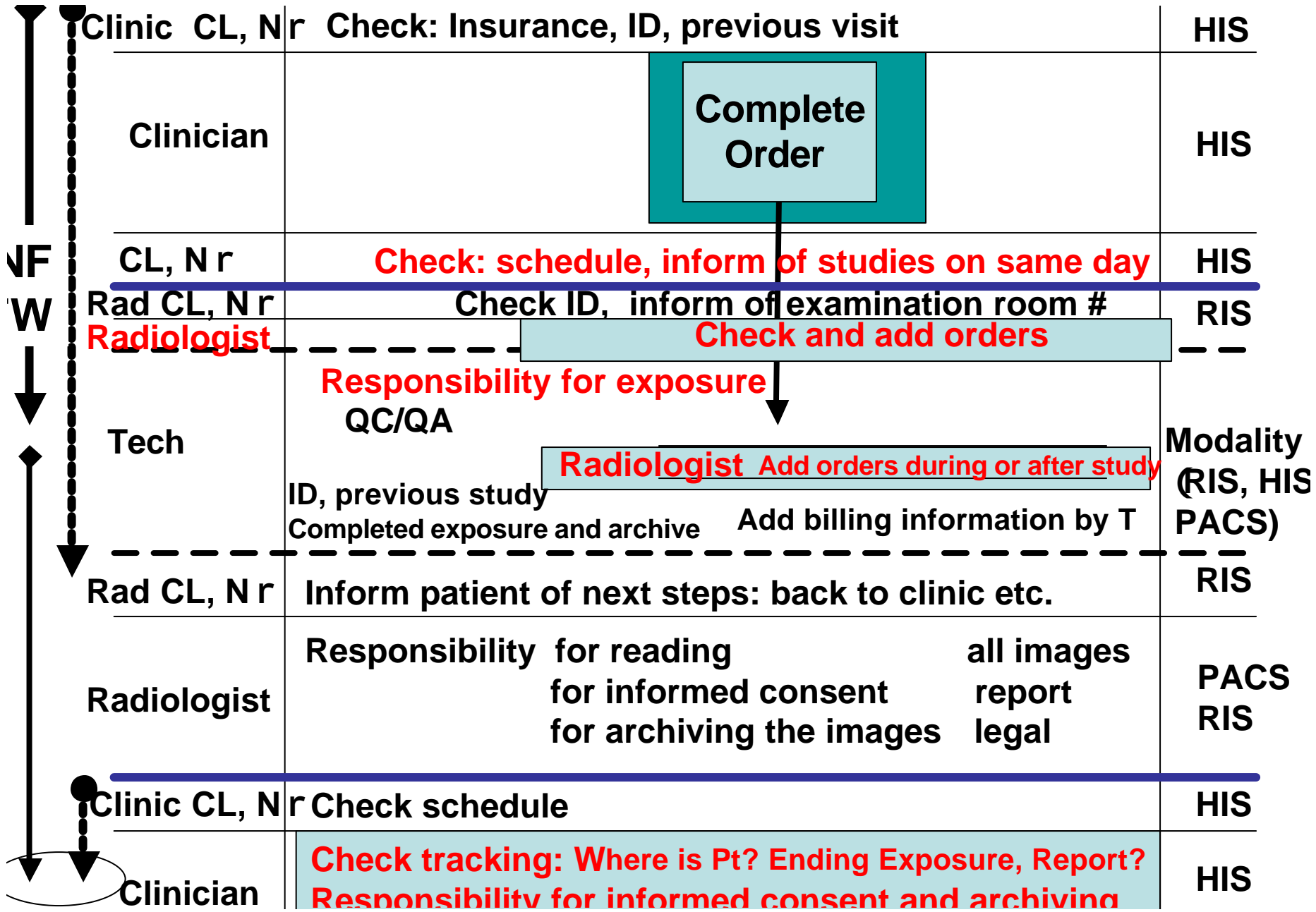

a scenario

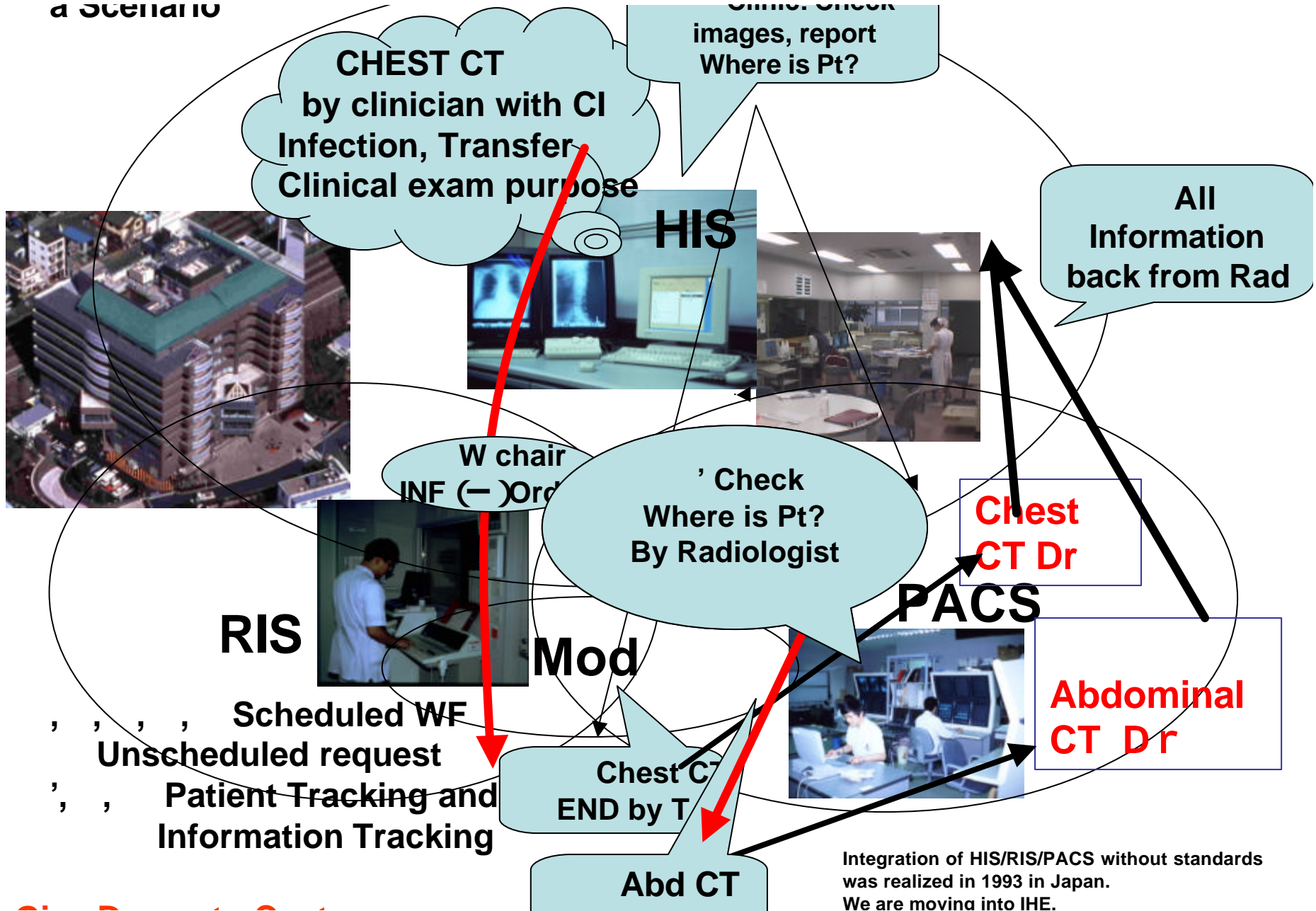

# Scenarios in 4 patterns

Clinicians or radiologists request a change in orders.

The person in charge conducts minimum operations (no phone calls, etc.) within his or her range of responsibilities.

- Scenario 1 [Adding an order](#) 2
- Scenario 2 [Canceling an order](#) 2
- Scenario 3 [Image acquisition without patient ID or name](#) 2
- Scenario 4 [Simultaneous image acquisition of multiple orders](#) 3
- Scenario 5 [Where is the patient? Completion of check and report](#) 4

- IHE
- 1 Scheduled WF
  - 2 Patient Information Reconciliation
  - 3 Presentation of Grouped Procedure
  - 4 Access to Radiology Information

# Example of scenario 1

- After obtaining and checking images, adding an order for CR, DR, CT, MR, etc.

Chest plus abdomen, etc.

HIS Who is added?

Completion of billing

# Example of scenario 2

- Order chest CT plain and contrast images

No target at the stage of acquiring plain images

Confirmation of the cancellation of contrast images

Cancelled at the stage of exposure

Who requested cancellation at HIS?

Completion of billing

# Example of scenario 3

- Injury due to a traffic accident, the name and identification of the patient are unknown.
- Order head CT, completion of plain and contrast images.
- Immediately before reading images, inform the system of the patient's name and ID.
- Doctor who reads the images  
begins reading images with the most up-to-date information

# Example of scenario 4

- Images of any modality OK
- Visit the department of internal medicine as an outpatient, order for December 10 on November 8
- Visit the department of orthopedics on December 10  
Order for neck images (urgent)
- Successive exposure of chest and neck in examination room
- After exposure,  
Specialists read images separately
- Issuance of orders by HIS separately
- Billing

# Example of slide 5

- The radiologist confirms whether the patient is in the department when an order is added, etc.
  - Regarding the check  
Completion of all preparations for reading images that need to be read urgently.  
  
Check whether images are completed.
- Clinical section, including clinicians and nurses
  - Check whether or not the patient has returned.
  - Check whether or not all information to be given to the patient is ready.

# Vertical Integration in the Department of Radiology

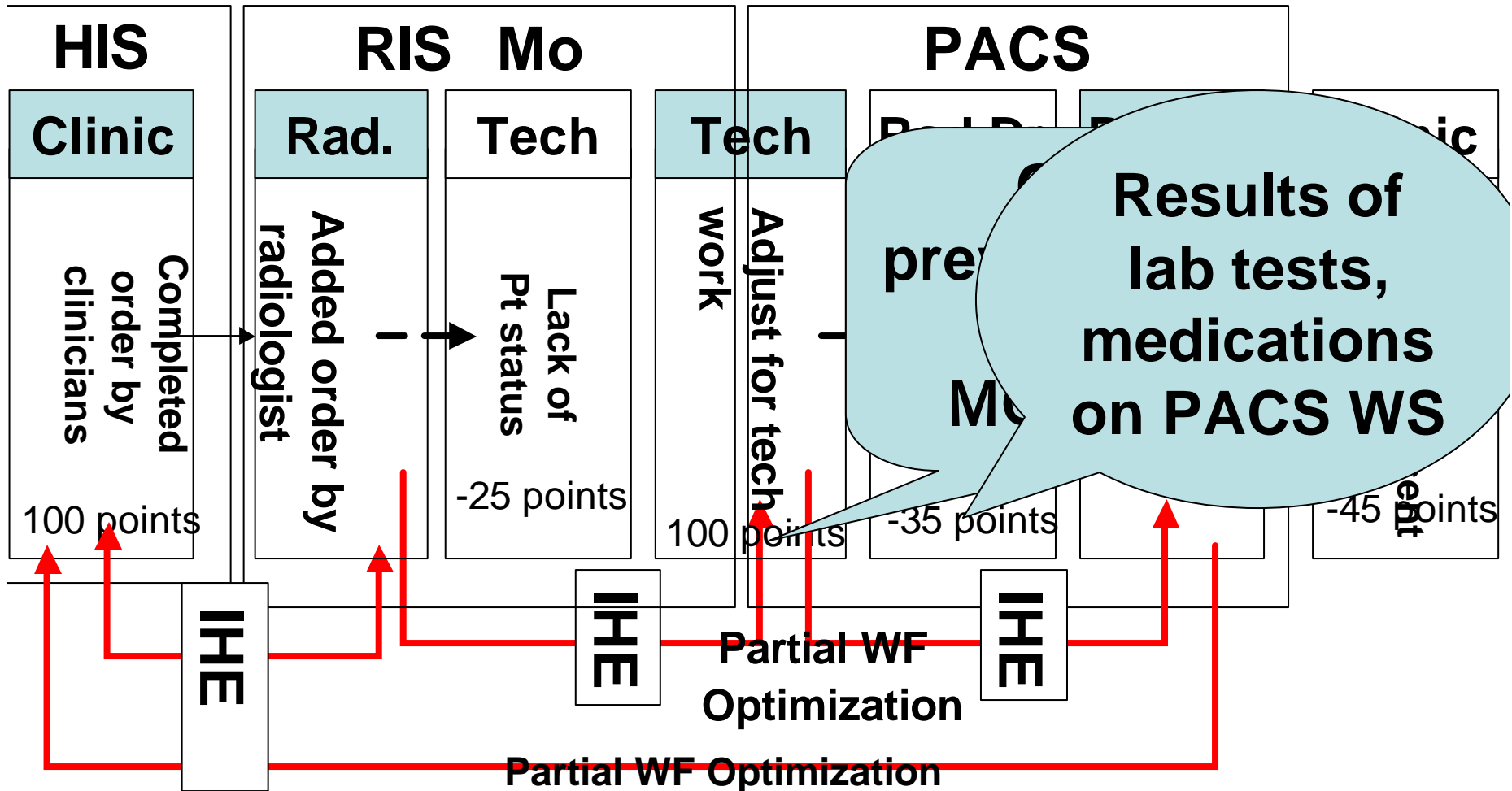

# Japanese Medical Facility

Acute and Chronic Patients

We have a 15-year history of order entry by the clinician for billing. Thus, horizontal integration in clinics has been realized by HIS.

Small Clinic  
Small Hospital  
Family Physician  
X-ray  
US  
Endoscopy  
All order completed by clinician, not radiologist.

We are now clarifying vertical integration by using DICOM and HL7.

No GP  
Family Doctor

Large Hospital

HIS in clinics  
order entry system  
operating since '80

Radiologist

Rad

US

Endo

⋮

Chronic Care Hospital

HIS

Rad

US

Endo

All control by clinician

